



BOSCH

Installation manual

Indoor unit for air to water heat pump

Compress 3000 AWES

AWES 2-6 | 8-15

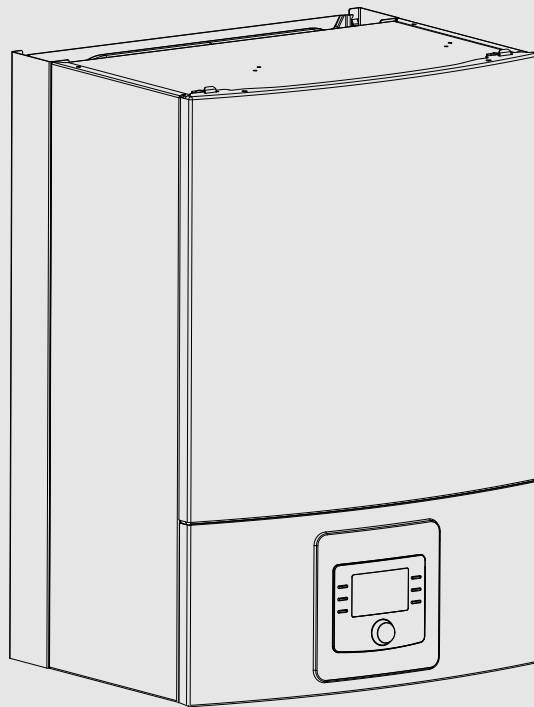

Table of contents

1	Explanation of symbols and safety instructions	3
1.1	Explanation of symbols	3
1.2	General safety instructions	3
2	Regulations	3
2.1	Water quality	4
3	Product description	4
3.1	Supplied parts	4
3.2	Information on the indoor unit	5
3.3	Declaration of Conformity	5
3.4	Type plate	5
3.5	Product overview	5
3.6	Product dimensions and minimum clearances	6
3.7	Pipe dimensions	6
4	Preparing for installation	6
4.1	Assembly of the indoor unit	6
4.2	Checks prior to installation	6
4.3	Functional principle	7
4.4	Intended use	7
4.5	Minimum volume and execution of the heating system	7
4.6	Preparatory pipework connections	7
4.7	Setting up	7
5	Installation	7
5.1	Insulation	8
5.2	Transport and storage	8
5.3	Unpacking	8
5.4	Connect the indoor unit	8
5.5	Checklist	9
5.6	Connection	10
5.6.1	Connecting the indoor unit with integrated electric booster heater	10
5.6.2	Filling the outdoor unit, indoor unit and heating system	10
5.6.3	Heating pump (PC0)	11
5.6.4	Heating circuit pump (PC1)	11
5.7	Electrical connection	12
5.7.1	EMS BUS	12
5.7.2	CAN-BUS	12
5.7.3	Handling printed circuit boards	13
5.7.4	Fitting temperature sensors	13
5.7.5	Flow temperature sensor TO	13
5.7.6	Outdoor temperature sensor T1	13
5.7.7	External connections	14
5.7.8	Connections of SEC 20 installer module of indoor unit with electric heater	15
5.7.9	Connection alternative for EMS bus	16
6	Commissioning	17
6.1	Venting the indoor unit	17
6.2	Adjusting the operating pressure of the heating system	17
6.3	Pressure switch and overheating protection	18
6.4	Function test	18

6.4.1	Operating temperatures	18
7	Maintenance	18
7.1	Particle filter	19
8	Installation of accessories	19
8.1	Temperature controller (accessory, see separate instructions)	19
8.2	External inputs	19
8.3	Installation of the domestic hot water cylinder	20
8.4	DHW cylinder temperature sensor TW1	20
8.5	Diverter valve VW1	20
8.6	Several heating circuits (with heating circuit module)	21
8.7	DHW circulation pump PW2 (accessory)	21
8.8	Installation with cooling	21
8.9	Installing the condensation point sensors (accessory for cooling mode)	21
8.10	Installation with swimming pool	21
8.11	Cooling only with fan convectors	22
8.12	IP module	22
9	Operation without the outdoor unit (individual operation)	23
10	Environmental protection and disposal	23
11	Technical information	23
11.1	Specifications – Indoor unit with electric booster heater	23
11.2	System solutions	24
11.2.1	Explanations of the system solutions	24
11.2.2	Bypass of the heating system	24
11.2.3	System solution with heat pump and indoor unit with integrated immersion heater	25
11.2.4	Explanation of symbols	26
11.3	Wiring diagram	27
11.3.1	Overview of electrical connections	27
11.3.2	CAN & EMS BUS	28
11.3.3	230 V/400 V terminal connections	29
11.3.4	400 V~ 3N indoor unit with 230 V~ 1N outdoor unit	30
11.3.5	400 V~ 3N indoor unit with 400 V~ 3N outdoor unit	31
11.3.6	EVU/SG wiring diagram for the indoor unit with an integrated electric booster heater	32
11.3.7	Photovoltaic	32
11.4	Kabelplan	32
11.5	Measurements from temperature sensors	32
12	System Commissioning Report	34

1 Explanation of symbols and safety instructions

1.1 Explanation of symbols

Warnings

In warnings, signal words at the beginning of a warning are used to indicate the type and seriousness of the ensuing risk if measures for minimizing danger are not taken.

The following signal words are defined and can be used in this document:

 **DANGER:**
DANGER indicates that severe or life-threatening personal injury will occur.

 **WARNING:**
WARNING indicates that severe to life-threatening personal injury may occur.

 **CAUTION:**
CAUTION indicates that minor to medium personal injury may occur.

NOTICE:
NOTICE indicates that material damage may occur.

Important information

 The info symbol indicates important information where there is no risk to people or property.

Additional symbols

Symbol	Meaning
▶	a step in an action sequence
→	a reference to a related part in the document
•	a list entry
–	a list entry (second level)

Table 1

1.2 General safety instructions

Notices for the target group

These installation instructions are intended for gas, plumbing, heating and electrical contractors. All instructions must be observed. Failure to comply with instructions may result in material damage and personal injury, including danger to life.

- ▶ Read the installation, service and commissioning instructions (heat source, heating controller, pumps, etc.) before installation.
- ▶ Observe the safety instructions and warnings.
- ▶ Follow national and regional regulations, technical regulations and guidelines.
- ▶ Record all work carried out.

Intended use

This product is intended for use in sealed heating systems in residential buildings.

Any other use is considered unsuitable. Liability will not be assumed for any resulting damage.

Installation, commissioning and service

The product may only be installed, brought into operation and maintained by trained personnel.

- ▶ Use only original spare parts.

Electrical work

Electrical work must only be carried out by electrical installation contractors.

Before starting electrical work:

- ▶ Isolate all poles of the mains voltage and secure against reconnection.
- ▶ Make sure the mains voltage is disconnected.
- ▶ Observe the wiring diagrams of other system components as well.

Handover to the user

When handing over, instruct the user how to operate the heating system and inform the user about its operating conditions.

- ▶ Explain how to operate the heating system and draw the user's attention to any safety relevant action.
- ▶ In particular, point out the following:
 - Alterations and repairs must only be carried out by an approved contractor.
 - Safe and environmentally compatible operation requires inspection at least once a year and responsive cleaning and maintenance.
- ▶ Point out the possible consequences (personal injury, including danger to life or material damage) of non-existent or improper inspection, cleaning and maintenance.
- ▶ Leave the installation instructions and the operating instructions with the user for safekeeping.

2 Regulations

This is an original manual. This manual may not be translated without the approval of the manufacturer.

Follow the directives and regulations given below:

- Local provisions and regulations of the electricity supplier and corresponding special rules
- National building regulations
- **F-Gas regulation**
- **EN 50160** (voltage properties in power grids for public distribution)
- **EN 12828** (heating systems in buildings - Design and installation of water-based heating systems)
- **EN 1717** (Protection of potable water against pollution in potable water installations)

2.1 Water quality

Water quality in the heating system

Heat pumps work at lower temperatures than other heating systems, which is why thermal deaerating is less effective and the remaining oxygen content is always higher than with electric, oil and gas heaters. This means that the heating system will be more sensitive to rust with aggressive water.

If heating systems have to be regularly refilled or if hot water samples from these systems are cloudy, corresponding measures such as retrofitting magnetic filters and air vents are needed before installing the heat pump.

A heat exchanger may be required to protect the heat pump if the specified limits cannot be reached.

Only use additives to increase the pH value and keep the water clean.

Water quality	Limit values for the heating system
Hardness	<3 °dH
Oxygen content	<1 mg/l
Carbon dioxide, CO ₂	<1 mg/l
Chloride ions, Cl ⁻	<250 mg/l
Sulphate, SO ₄	<100 mg/l
Conductivity	<350 µS/cm
pH	7.5 – 9

Table 2 Water quality in the heating system

3 Product description

3.1 Supplied parts

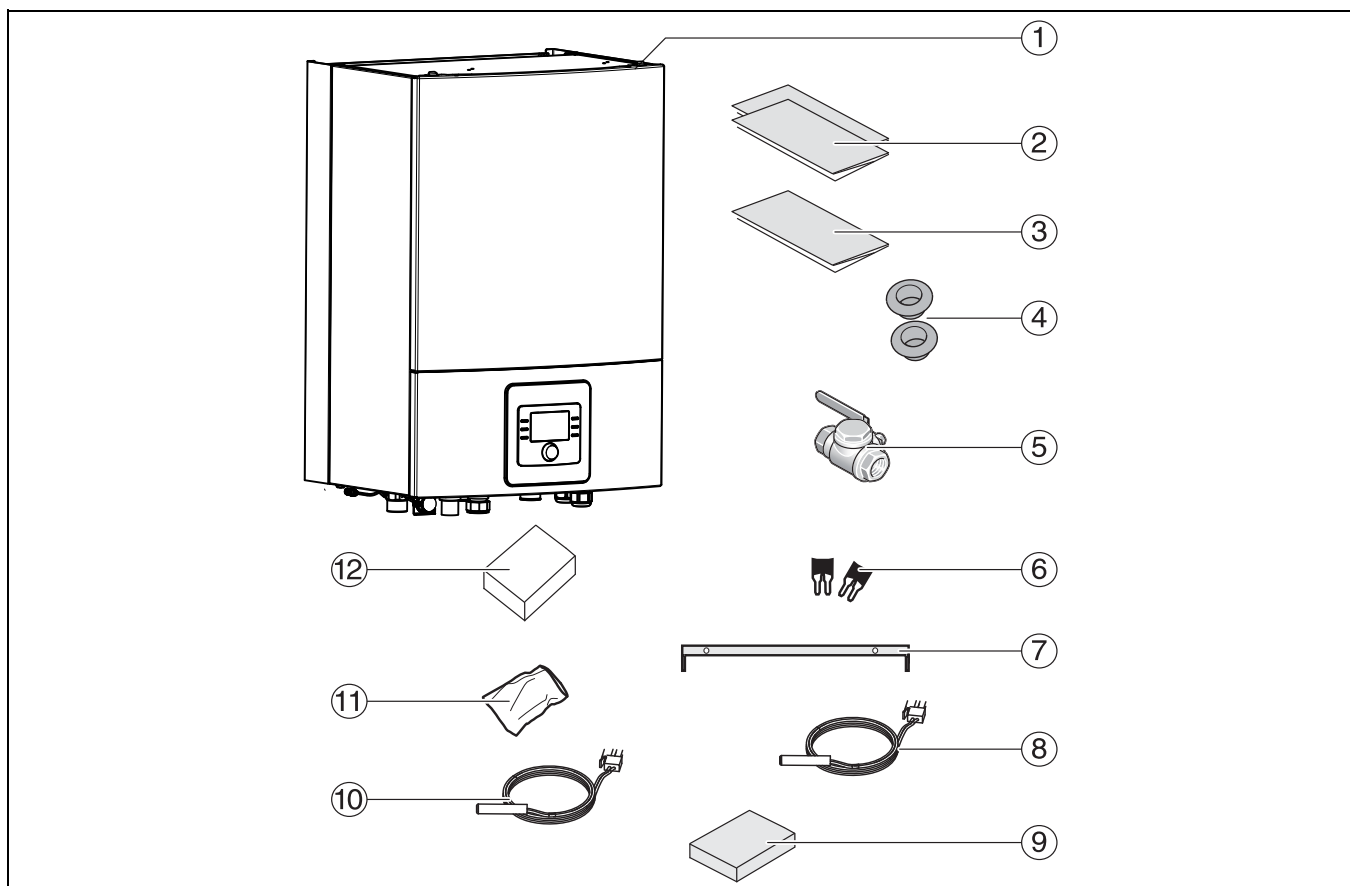

Fig. 1 Supplied parts

- [1] Indoor unit
- [2] Documentation
- [3] Drill template
- [4] Cable feeds
- [5] Particle filter with strainer
- [6] Jumpers for 1-phase installation
- [7] Mounting rail
- [8] Flow temperature sensor
- [9] Packaging includes terminals for the installation module
- [10] DHW temperature sensor
- [11] Bag with screws
- [12] Outdoor sensor

3.2 Information on the indoor unit

The AWES indoor units are intended for installation inside the building and connection to the outdoor unit.

Possible combinations:

AWES	Outdoor unit (ODU)
2-6	4
2-6	6
8-15	8
8-15	11s/t
8-15	13s/t
8-15	15 s/t

Table 3 Selection table for wall mounted heat pump indoor units AWES

AWES is equipped with an integrated electric booster heater.

3.3 Declaration of Conformity



The design and operation of this product comply with European Directives and the supplementary national requirements. Conformity has been demonstrated by the CE marking.

You can ask for a copy of the Declaration of Conformity for this product. Please refer to the contact address on the back cover of these instructions.

3.4 Type plate

The data plate of the indoor unit is on the control device behind the cover. It contains information on the part number and serial number and also the date of manufacture of the device.

3.5 Product overview

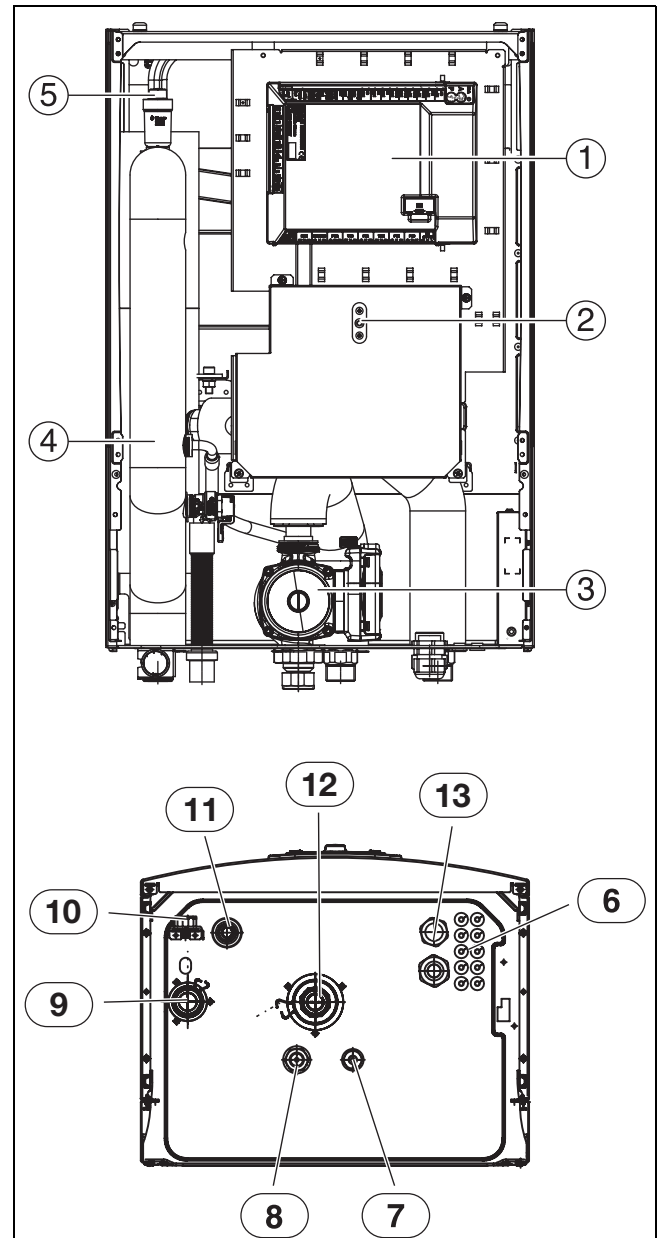

Fig. 2 Components and pipework connections of the indoor unit with electric booster heater

- [1] Installer module
- [2] Resetting the overheating protection
- [3] Circulation pump
- [4] Electrical heater
- [5] Automatic air vent valve (VL1)
- [6] Cable feed for sensor, CAN-BUS and EMS BUS
- [7] Heat transfer medium out to ODU outdoor unit 3/8" (Liquid)
- [8] Heat transfer medium in from ODU outdoor unit 5/8" (Gas)
- [9] Flow to heating system
- [10] Pressure gauge
- [11] Drain of the pressure relief valve
- [12] Return from the heating system
- [13] Cable feed for power supply

3.6 Product dimensions and minimum clearances



Mount the indoor unit high enough so that the control unit is easy to use. In addition, take into account pipes and connections under the indoor unit.

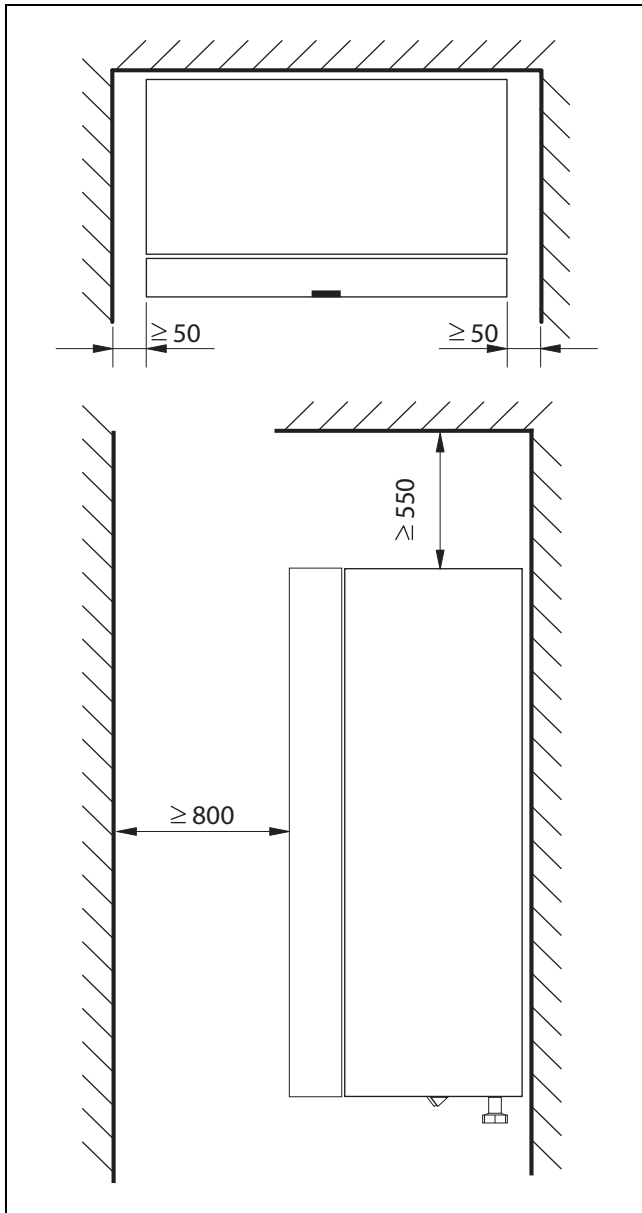

Fig. 3 Minimum distance (mm)

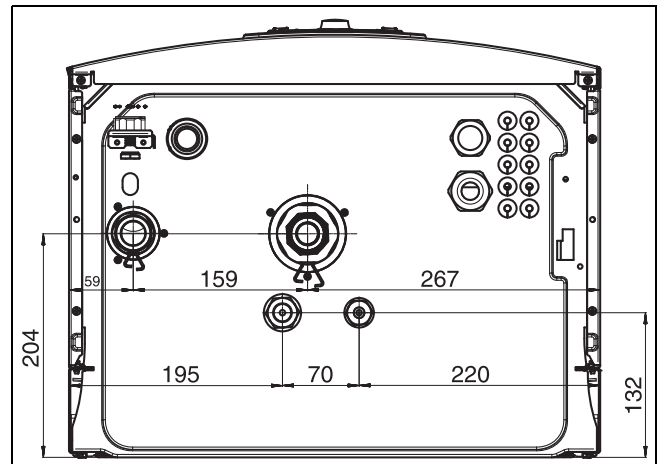

Fig. 4 Dimensions and connections

3.7 Pipe dimensions

Pipe dimensions (mm)	AWES
Heating system flow	1" male thread
CH return	1" female thread
Refrigerant pipe to/from outdoor unit	5/8" and 3/8"
Drain/discharge	ø 32

Table 4 Pipe dimensions

4 Preparing for installation



The particle filter is installed horizontally in the heating system return upstream of the inlet of the indoor unit. Note the direction of flow of the filter.



The drain pipe of the pressure relief valve in the indoor unit must be installed so that it is protected against frost, and the drain pipe must be routed to the drain.

- ▶ Run the connector pipes for the heating system and cold/domestic hot water in the building up to the installation location of the indoor unit.

4.1 Assembly of the indoor unit

- Mount the indoor unit on a suitable wall within the house. The length of piping between the outdoor unit and indoor unit must be as short as possible. Use insulated pipes.
- Water discharged from the pressure relief valve should be routed away from the indoor unit to visibly terminate in a frost-free outlet.
- The installation location for the indoor unit must have a drain.

4.2 Checks prior to installation

- Check that all pipe connections are intact and have not come loose during transportation.
- Before commissioning the indoor unit, check the heating system and, if installed, fill and vent the DHW cylinder.
- All pipework should be as short as possible.
- The low voltage cables must be routed with a minimum clearance of 100 mm from live 230 V/400 V cables.

4.3 Functional principle

The function is based on the demand-actuated control of the compressor output by switching in the integrated auxiliary heater via the indoor unit. The control unit controls the outdoor unit depending on the set heating curve.

If the outdoor unit is unable to satisfy the house's heat energy demand, the indoor unit automatically starts the auxiliary heater which produces the desired temperature in the house together with the outdoor unit.

The DHW heating is controlled via the TW1 sensor in the DHW cylinder. During the heat-up phase of the DHW cylinder, the heating mode of the heating system is temporarily switched off via a 3-way valve (accessory). Once the DHW cylinder is heated up, heating mode is continued by the outdoor unit.

Heating and DHW mode when the outdoor unit is deactivated

When the outdoor temperature is less than -20°C (adjustable), the outdoor unit is automatically turned off and is unable to produce any heat. In this case, the auxiliary heater of the indoor unit adopts the heating and DHW mode.

4.4 Intended use

The wall mounted indoor unit must only be installed in sealed heating systems according to EN 12828.

Any other use is considered improper use. Any damage that results from such use is excluded from liability.

4.5 Minimum volume and execution of the heating system



Ensure the minimum flow rate according to the specifications in the chapter 11.1.



To safeguard the heat pump function and avoid an excessive number of start/stop cycles, incomplete defrosting and unnecessary alarms, it must be possible to store a sufficient amount of energy in the system. This energy is stored in the water volume of the heating system, and also in the components of the system (radiators) and concrete floor (underfloor heating system).

As the requirements for different heat pump installations and heating systems vary considerably, a minimum water volume in litres is generally not specified. Instead, the system volume is considered to be sufficient if certain conditions are met.

Only an underfloor heating circuit without buffer cylinders, no mixer:

For the heat pump and defrosting function to work, at least 22 m^2 of heatable floor area must be available. Furthermore, a temperature controller must be installed in the largest room (reference room). The room temperature measured by the temperature controller is used to calculate the flow temperature (principle: weather-compensated control with room temperature hook-up). All zone valves of the reference room must be completely open. In certain situations, the electric booster heater can be activated to ensure complete defrosting. That depends on the available floor space.

Only the radiator circuit without a buffer cylinder or mixer

For the heat pumps and defrosting function to work properly, there must be at least 4 radiators with an output of at least 500 W. Make sure that the thermostatic valves of these radiators are fully opened. If this condition can be met within a living area, a temperature controller is recommended for this reference room so that the measured room temperature can be used to calculate the flow temperature. In certain

situations, the electric booster heater can be activated to ensure complete defrosting. This depends on the available radiator surface area.

Heating system with 1 heating circuit without mixer and 1 heating circuit with mixer without a buffer cylinder

For the heat pumps and defrosting function to work properly, the heating circuit without mixer must have at least four radiators with an output of at least 500 W. Make sure that the thermostatic valves of these radiators are fully opened. In certain situations, the electric booster heater can be activated to ensure complete defrosting. This depends on the available radiator surface area.

Special feature

If both heating circuits have different operating times, each heating circuit must be able to ensure the operation of the heat pump independently. Make sure that at least 4 radiator valves of the heating circuit without mixer are completely open and that a floor surface area of at least 22 m^2 is available for the (underfloor) heating circuit with mixer. In this case, temperature controllers are recommended for the reference rooms of both heating circuits so that the measured room temperature can be used to calculate the flow temperature. In certain situations, the electric booster heater can be activated to ensure complete defrosting. If both heating circuits have identical operating times, the heating circuit with mixer does not require a minimum area because the 4 radiators with a constant flow ensure the operation of the heat pumps. A temperature controller is recommended in the area of the open radiator valves so that the outdoor unit automatically adjusts the flow temperature.

Only heating circuits with mixer (also applies to heating circuits with fan convectors)

To ensure that a sufficient amount of energy is available for defrosting, a buffer cylinder with a minimum capacity of 50L for sizes 2-6 and 100L for sizes 8-15 is required.

An additional heating circuit pump is a prerequisite for this.

4.6 Preparatory pipework connections



The ball valve with particle filter is installed horizontally in the return of the heating system. Note the direction of flow of the filter.



The drain pipe of the pressure relief valve in the indoor unit must be installed protected against frost, and the drain pipe must be run to visibly terminate in a drain.

4.7 Setting up

- ▶ Dispose of the packaging according to the instructions on the packaging.
- ▶ Take out the enclosed accessories.

5 Installation

NOTICE:

Residue in the pipework can damage the system.

Residue and particles in the heating system impair the flow rate and lead to faults.

- ▶ Before connecting the indoor unit, flush the pipe system to remove any foreign bodies.

**CAUTION:****Risk of injury!**

During transport and installation there are a risk of crushing injury. During maintenance internal parts of the appliance can become hot.

- ▶ The installer are obliged to wear gloves during transport, installation and maintenance.

The indoor unit is part of a heating system. Faults in the indoor unit can occur from poor water quality in the radiators or pipework of the underfloor heating system, or when the oxygen content in the system is persistently high.

Oxygen causes corrosion products in the form of magnetite and sediment.

Magnetite is an abrasive material which affects pumps, valves and components with turbulent flow characteristics, e.g. in the condenser.

If heating systems have to be regularly refilled or if hot water samples from these systems are cloudy, corresponding measures such as retrofitting magnetite separators and air vents are required.

- ▶ Ensure the insides of the pipes are clean and do not contain any harmful contaminants such as sulphuric compounds, oxidants, debris and dust.
 - Never store refrigerant pipes outdoors.
 - Only unseal the pipe ends when you are ready to connect them to the cold side.
 - Utmost care must be taken when routing refrigerant lines.
 - Only shorten refrigerant lines using pipe cutters and seal the ends afterwards to prevent the ingress of dirt and moisture.

Dust, foreign bodies and moisture inside the refrigerant lines can be detrimental to oil quality or can result in compressor failure.

- ▶ After cutting, immediately reseal reusable lengths of refrigerant lines.

NOTICE:**Danger of faults due to contaminants in pipework!**

Solids, metal/plastic filings, flax and thread tape residue and similar material can get stuck in pumps, valves and heat exchangers.

- ▶ Keep foreign bodies from entering the pipework.
- ▶ Do not leave pipe parts and connections directly on the ground.
- ▶ When deburring, make sure that no residue remains in the pipe.

NOTICE:

Make sure that you use the right sensor with the appropriate characteristics when exchanging a sensor (Chapter 11.5). Using sensors with other characteristics leads to problems since the system is controlled with reference to the incorrect temperature. Personal injury such as scalding as well as damage to property can occur due to an excessively high or low temperature. Comfort can also be adversely affected by using the incorrect sensors.

5.1 Insulation

All heat-conducting pipework must be provided with suitable thermal insulation according to the applicable regulations.

NOTICE:**Material damage from frost!**

In case of a power outage the water in the pipes may freeze.

- ▶ All heat-conducting pipework must be provided with suitable thermal insulation according to applicable regulations.

If it is envisaged that the cooling operation be carried out below the dew point, all connections and cables must be appropriately insulated in accordance with the valid regulations (minimum insulation thickness 13 mm).

5.2 Transport and storage

The indoor unit must always be transported and stored in an upright position. It can be tilted provisionally if required.

Do not store or transport the indoor unit at temperatures below -10°C .

5.3 Unpacking

- ▶ Remove the packaging according to the instructions on the packaging.
- ▶ Take out enclosed accessories.
- ▶ Check that all package contents are present.

5.4 Connect the indoor unit

Fig. 5 Remove front cover

- ▶ Remove front cover (start at bottom)
- ▶ Remove the lock of the control device.
- ▶ Feed the connecting lead through the cable feeds to the control device.
- ▶ Connect the cable as shown in the wiring diagram.
- ▶ Reinstall the control device lock and front cover of the indoor unit.

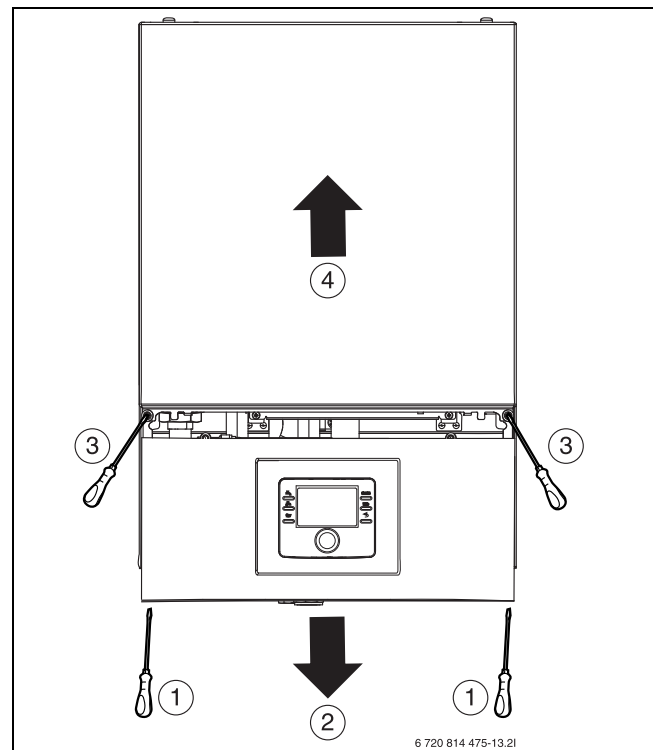
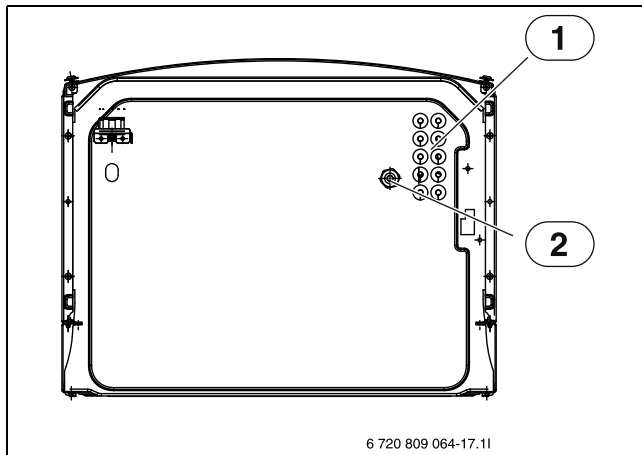

Fig. 6 Cable feeds (view from below)

- [1] Cable feed for sensor, CAN-BUS and EMS BUS
- [2] Cable feed for power input

5.5 Checklist



Each installation is different. The following checklist contains a general description of the recommended installation steps.



The refrigerant line should be connected before the hydraulic connections as a recommendation.

1. Install the incoming and outgoing pipes of the indoor unit.
2. Mount the leakage water hose or pipework of the indoor unit.
3. Connect the ODU outdoor unit and indoor unit (→ instructions for the outdoor unit).
4. Connect the indoor unit to the heating system. (→ chapter 5.4).
5. Fill and vent DHW cylinder.
6. Before starting operation, fill the heating system and vent it (→ Chapter 5.6.2 and 6.1).
7. Vent heating system (→ Chapter 5.7).
8. Install the outside temperature sensor (→ Chapter 5.7.6) and, if necessary, the room temperature-dependent controller.
9. Connect the CAN-BUS pipework between the outdoor unit ODU and indoor unit (→ Chapter 5.7.2).
10. Install any accessories (heating circuit module, solar module, etc.).
11. If needed, connect the EMS BUS cable to the accessory (Chapter 5.7.1).
12. Connect the heating system to the mains power supply (→ Chapter 6.1).
13. Bring the heating system into operation. Use the control unit to make the necessary settings (→ instructions for control unit).
14. Check that all sensors display the appropriate values (→ Chapter 7).
15. Check and clean the particle filter (→ Chapter 7).
16. Check the operation of the heating system after starting up (→ Chapter 6.4).

5.6 Connection

5.6.1 Connecting the indoor unit with integrated electric booster heater

Install the following connections at the indoor unit:

1. Run the drain hose from [6] fig. 7 to a frost protected outlet.

2. Connect heat transfer medium pipes from the heat pump to [2] fig. 7.
3. Connect heat transfer medium pipes to the heat pump [1] fig. 7.
4. Connect the return from the heating system to [7] fig. 7.
5. Connect the flow from the heating system to [5] fig. 7.

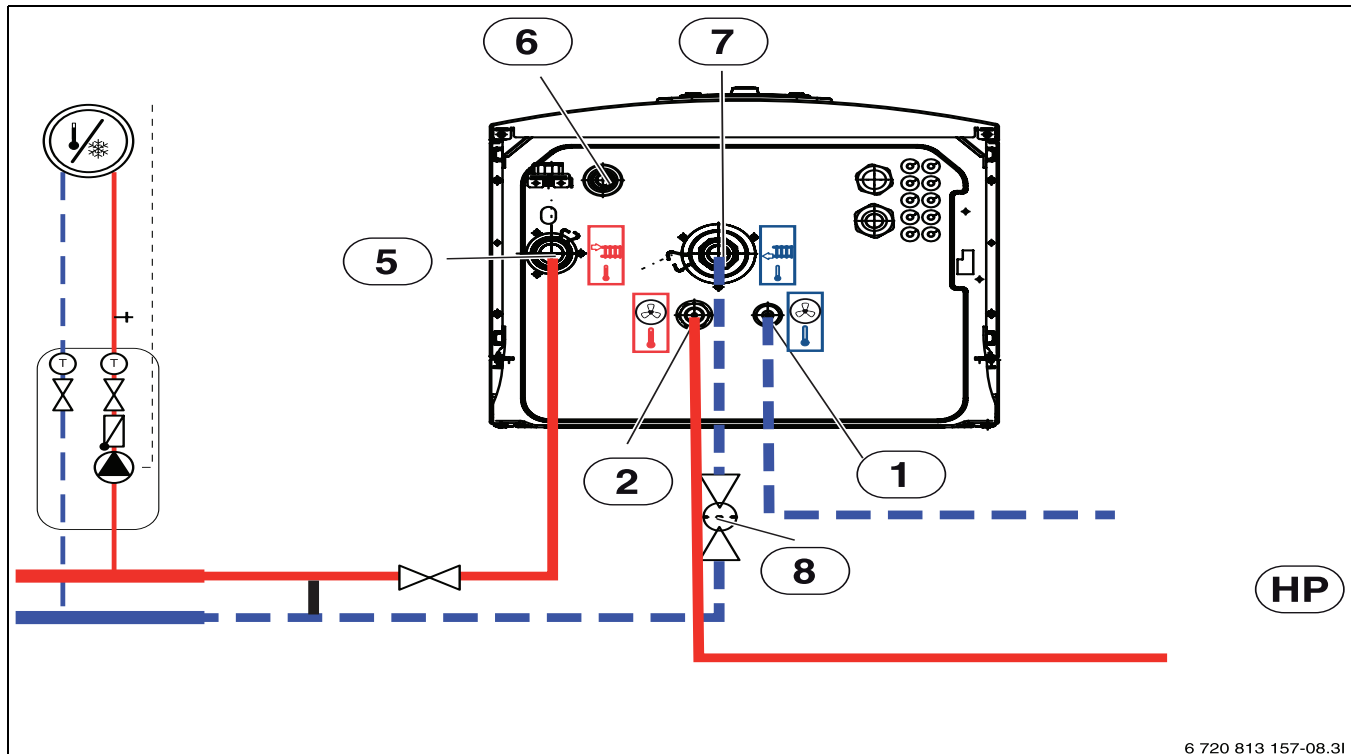

Fig. 7 Connection of an indoor unit with an immersion heater to a heat pump and heating system

- [1] Heat transfer medium out to ODU outdoor unit 3/8" (Liquid)
- [2] Heat transfer medium in from ODU outdoor unit 5/8" (Gas)
- [5] Flow to heating system
- [6] Waste water outlet, outlet from pressure relief valve
- [7] Return from heating system
- [8] Water/air filter

5.6.2 Filling the outdoor unit, indoor unit and heating system

Purge the heating system first. If the DHW cylinder is connected to the system, it must be filled with water and also purged.

Then fill the heating system.



After the system has been filled, vent it thoroughly and clean the water filter.

- ▶ Fill the system according to these instructions.
- ▶ Start the system according to the instructions for the control unit.
- ▶ Vent the system according to the chapter 6.1.
- ▶ Clean the particle filter as described in chapter 7.1.

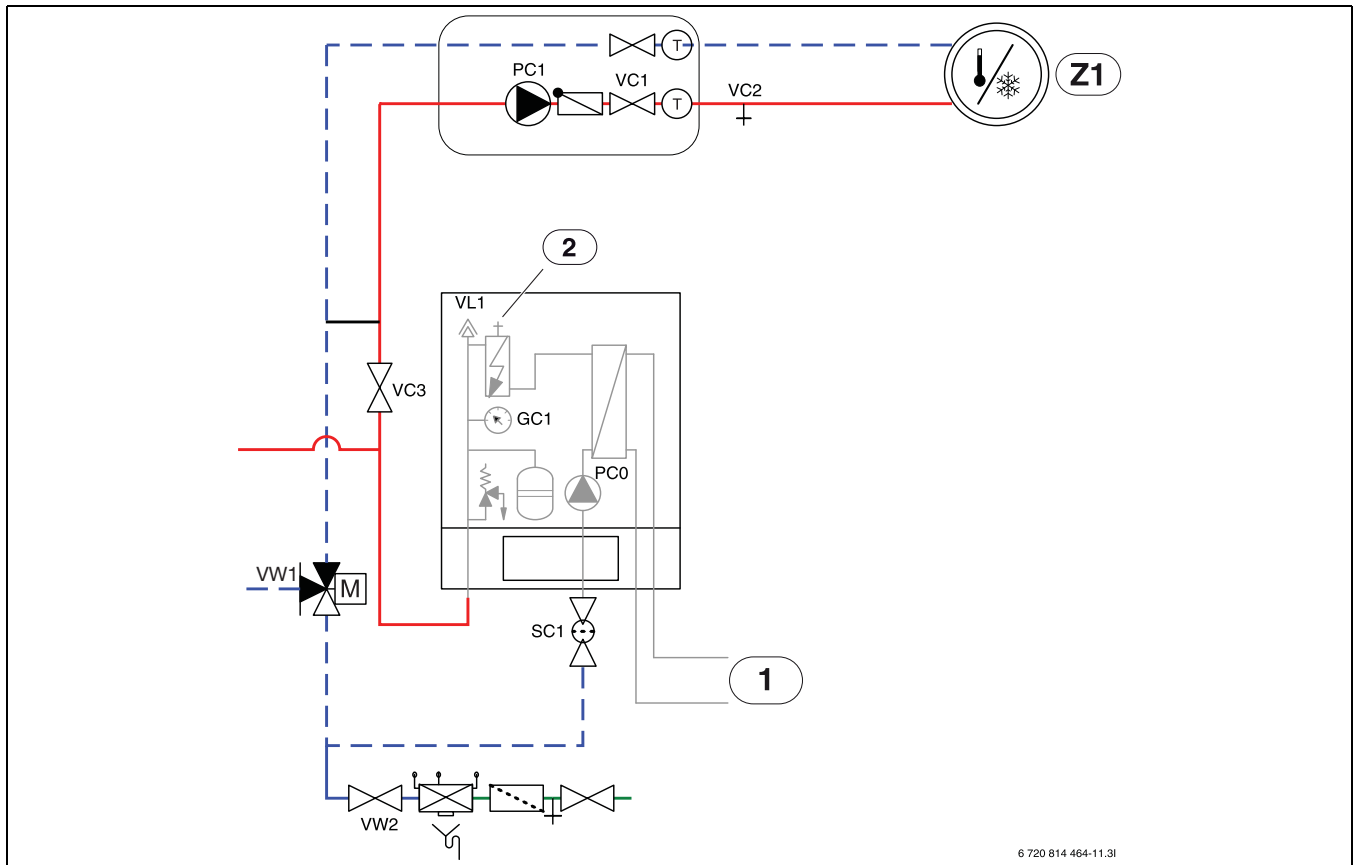

Fig. 8 Indoor unit with integrated immersion heater and heating system

- [Z1] Heating system (without mixing valve)
- [1] Heat pump, outdoor unit
- [2] Manual air vent valve
- [PC0] Heating pump
- [VC2] Drain valve
- [VC3] Valves for the heating system
- [VL1] Automatic air vent valve
- [GC1] Pressure gauge
- [SC1] Water/air filter
- [VW1] 3-way mixing valve
- [VW2] Fill valve

See fig. 8:

1. Make sure the power supply to the heat pump and indoor unit is not connected before the system has been completely filled and vented.
2. Activate automatic venting of VL1 by unscrewing the screw a couple of turns without removing it.
3. Connect a hose to the heating system drain valve VC2.
4. Open the valve VC3, drain valve VC2 and fill valve VW2 to fill the heating system.
5. Open the manual air vent valve on top of the electric heater until water discharges without air. Close the valve afterwards.
6. Continue filling until only water comes out of the outlet hose and bubbles no longer form in the heating system. Where appropriate, take additional measures to vent the heating system.
7. Close the drain valve VC2.
8. Keep filling until the pressure display GC1 shows 2 bar.
9. If a DHW cylinder is installed, also fill and vent this.
10. Close the fill valve VW2.
11. Remove the hose from VC2.
12. → Chapter 6.1.

5.6.3 Heating pump (PC0)

The PC0 heating pump (integrated into AWES) is equipped with a PWM control (speed-controlled). The pump settings are made at the control

unit of the indoor unit for the given heating system (→ instructions of the control unit).

The pump speed is automatically adjusted for optimum operation.

5.6.4 Heating circuit pump (PC1)

i Depending on the hydraulic layout and configuration of the heating system, a pump is needed that is selected depending on the flow rate and pressure drop requirements.

i The pump PC1 must always be connected to the installation module of the indoor unit according to the wiring diagram.

i Maximum load at the relay output of the pump PC1: 2 A, cosφ > 0.4. If the load is higher, install an intermediate relay.

5.7 Electrical connection



DANGER:

Electrical shock!

The heat pump components conduct electricity.

- ▶ Before working on the electrical system, disconnect the components from the power supply.

NOTICE:

The system will be damaged if it is turned on without water.

If the system is turned on before it is filled with heating system water, the heating system components can overheat.

- ▶ Fill, vent and establish the correct operating pressure in the DHW cylinder and heating system **before** turning on the heating system.



The electrical connection for the indoor unit must be safely interruptable.

- ▶ Install a separate safety switch that completely de-energizes the indoor unit. When the power supply is separate, a separate safety switch is needed for each supply line.
- ▶ Select the appropriate conductor cross-sections and cable types for the respective fuse protection and routing method.
- ▶ Connect the heat pump according to the wiring diagram. No additional consumers may be connected.
- ▶ When changing the PCB, note the colour coding.
- ▶ Ensure to install residual current device based on normative requirements in each country. We recommend to use residual current device type B.

5.7.1 EMS BUS

NOTICE:

Malfunction due to faults!

High-voltage lines (230/400 V) in the vicinity of communication lines can cause the heat pump to malfunction.

- ▶ Route the EMS-BUS cable separately to the power cables. Maintain a minimum distance of 100 mm. Routing alongside sensor cables is permitted.



EMS-BUS and CAN-BUS are not compatible.

- ▶ Do not connect EMS-BUS units to CAN-BUS units.

The control unit is connected via the EMS BUS to the installation module in the indoor unit.

The control unit is supplied with power via the BUS cable. The polarity of the two EMS BUS cables is irrelevant.

The following applies for accessories that are connected to the EMS BUS (see also the installation instructions for the respective accessories):

- ▶ If several BUS units are installed, there must be a minimum spacing of 100 mm between them.
- ▶ If several BUS units are installed, connect them in parallel or in a star configuration.
- ▶ Use cable with a minimum cross-section of 0.75 mm².
- ▶ In case of external inductive interferences (e.g. from PV systems), use screened cables. Only earth the shielding to the casing on one side.

5.7.2 CAN-BUS

NOTICE:

Malfunction due to faults!

High-voltage lines (230/400 V) near communication lines can cause the indoor unit to malfunction.

- ▶ Run the screened CAN-BUS cable separate from the power cables. Maintain a minimum distance of 100 mm. Routing alongside sensor cables is permitted.



CAN-BUS: do not connect 12 V direct voltage output "Out 12 V DC" on the installation module.

NOTICE:

Mixing up the 12 V and CAN-BUS connections will result in a system fault!

The communication circuits are not designed for a constant voltage of 12 V.

- ▶ Make sure that both cables are connected to the correspondingly marked connections on the printed circuit board (CAN high / CAN low).

The outdoor unit and indoor unit are connected via a communication cable, the CAN-BUS.

A LIYCY cable (TP) 2 x 2 x 0.75 (or equivalent) is suitable **as an extension cable outside of the unit**. Alternatively, twisted pair cables approved for outdoor use with a minimum cross-section of 0.75 mm² can be used. The shield should be earthed at both ends:

- ▶ At casing of the indoor unit
- ▶ To the earth terminal of the outdoor unit.

The connection between the printed circuit boards is by two wires because the 12 V supply from the installer module must not be connected.

The **Term** switch marks the start and end of the CAN-BUS connection. Make sure that the right boards are terminated and that all other boards within the CAN-BUS connection are not terminated.

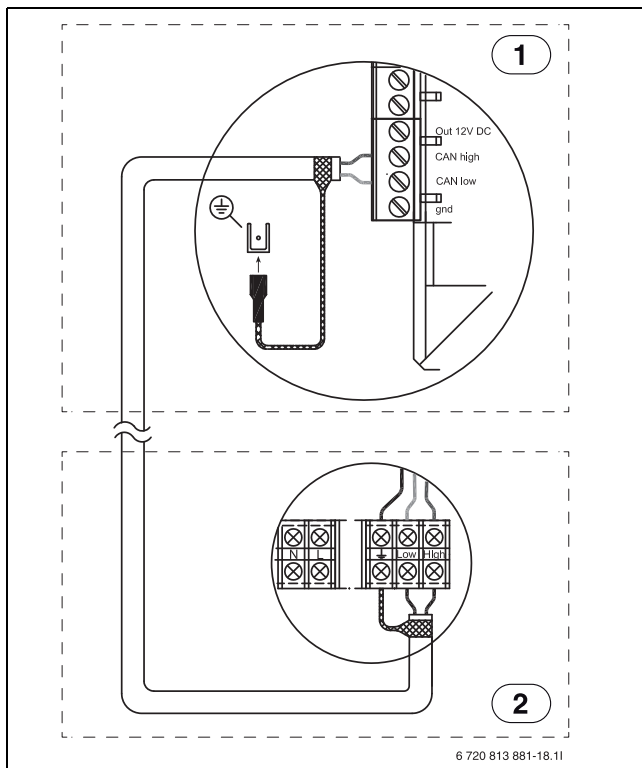

Fig. 9 CAN-BUS connection

- [1] indoor unit
- [2] outdoor unit

5.7.3 Handling printed circuit boards

Printed circuit boards with control electronics are very sensitive to electrostatic discharge (ESD). To prevent damage to the components, special care is therefore required.

CAUTION:

Damage due to electrostatic charge!

- ▶ Wear an ESD wrist strap when handling unenclosed PCBs.

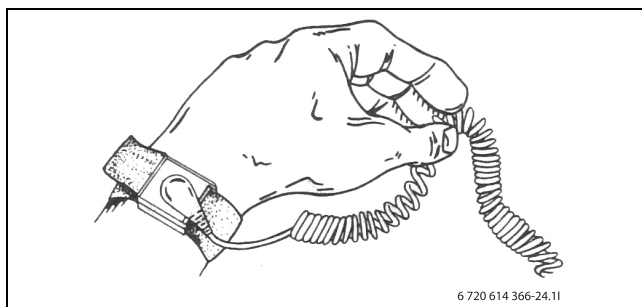

Fig. 10 Wrist strap

The damage is not normally immediately recognisable. A PCB may function perfectly during commissioning and problems often only arise later on. Charged objects are only a problem if they are in the vicinity of the electronics. Observe a safety clearance of at least one metre from foam rubber, protective film and other packaging materials, and do not wear clothing made of synthetic fibres (e.g. fleece pullovers) and similar, when you start work.

An earthed wrist strap offers good ESD protection when working with electronics. This wrist strap must be worn when opening the screened metallic bag/packaging or prior to exposing a fitted PCB. The wrist strap must be worn until the PCB has been placed inside its screened packaging or has been connected inside the closed control device. Replaced PCBs that are returned must be handled in this way.

5.7.4 Fitting temperature sensors

In the default setting, the control unit automatically controls the flow temperature based on the outdoor temperature. A room temperature-dependent controller can be installed for greater comfort. If cooling mode is intended, a temperature controller is absolutely essential.

5.7.5 Flow temperature sensor T0

The temperature sensor is part of the scope of delivery of the indoor unit.

- ▶ Install the temperature sensor 1-2 metres downstream of the 3-way valve or on the buffer cylinder, if installed.
- ▶ Connect the flow temperature sensor on the installation module in the control device of the indoor unit to terminal T0.

5.7.6 Outdoor temperature sensor T1



A screened cable must be used if the outdoor temperature sensor cable is longer than 15 m. The screened cable must be earthed in the heat pump. The max. length of a screened cable is 50 m.

The cable to the outdoor temperature sensor must meet the following minimum requirements:

- Cable diameter: 0.5 mm²
- Resistance: max. 50 ohm/km
- Number of conductors: 2
- ▶ Mount the sensor on the coldest side of the house, normally facing north. The sensor must be protected against direct sunlight, ventilation air or other factors which could affect temperature measurement. The sensor may not be installed directly under the roof.
- ▶ Connect the outdoor temperature sensor T1 to the terminal T1 on the installer module.

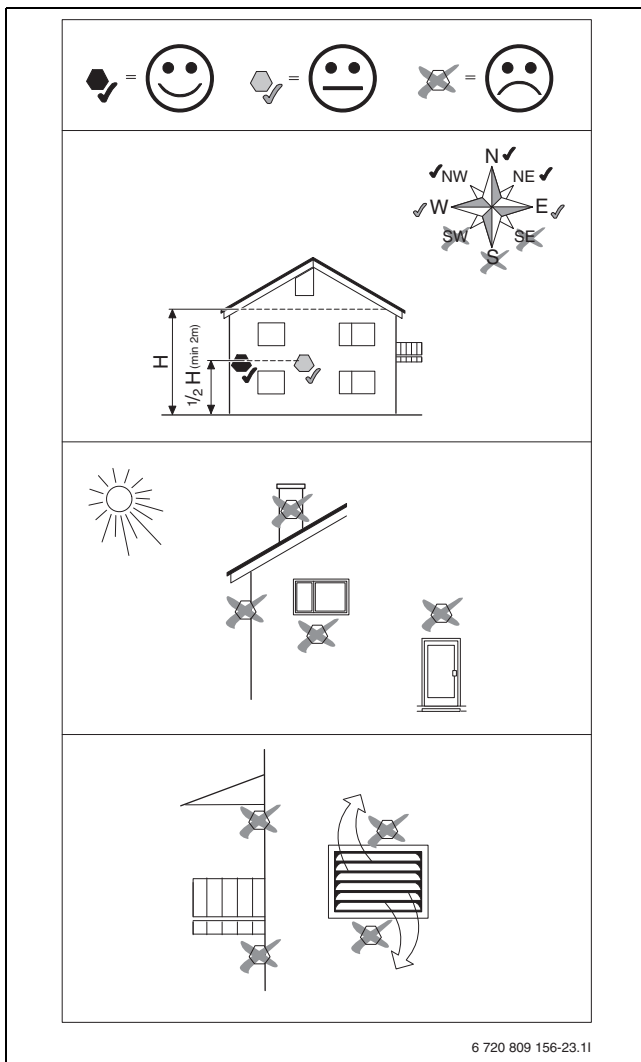

Fig. 11 Outdoor temperature sensor positioning

5.7.7 External connections

NOTICE:

Material damage due to incorrect connection!

The electrical components may become damaged if connected to the wrong voltage or current.

- ▶ Only make connections that are adapted for 5 V and 1 mA to the external connections of the indoor unit.
- ▶ If coupling relays are required, only use relays with gold contacts.

The external inputs I1 and I4 can be used for remote control of individual control unit functions.

Functions which are activated via the external inputs are described in the instructions for the control unit.

The external input is either connected to a manual switch or a control device with a 5 V relay output.

5.7.8 Connections of SEC 20 installer module of indoor unit with electric heater

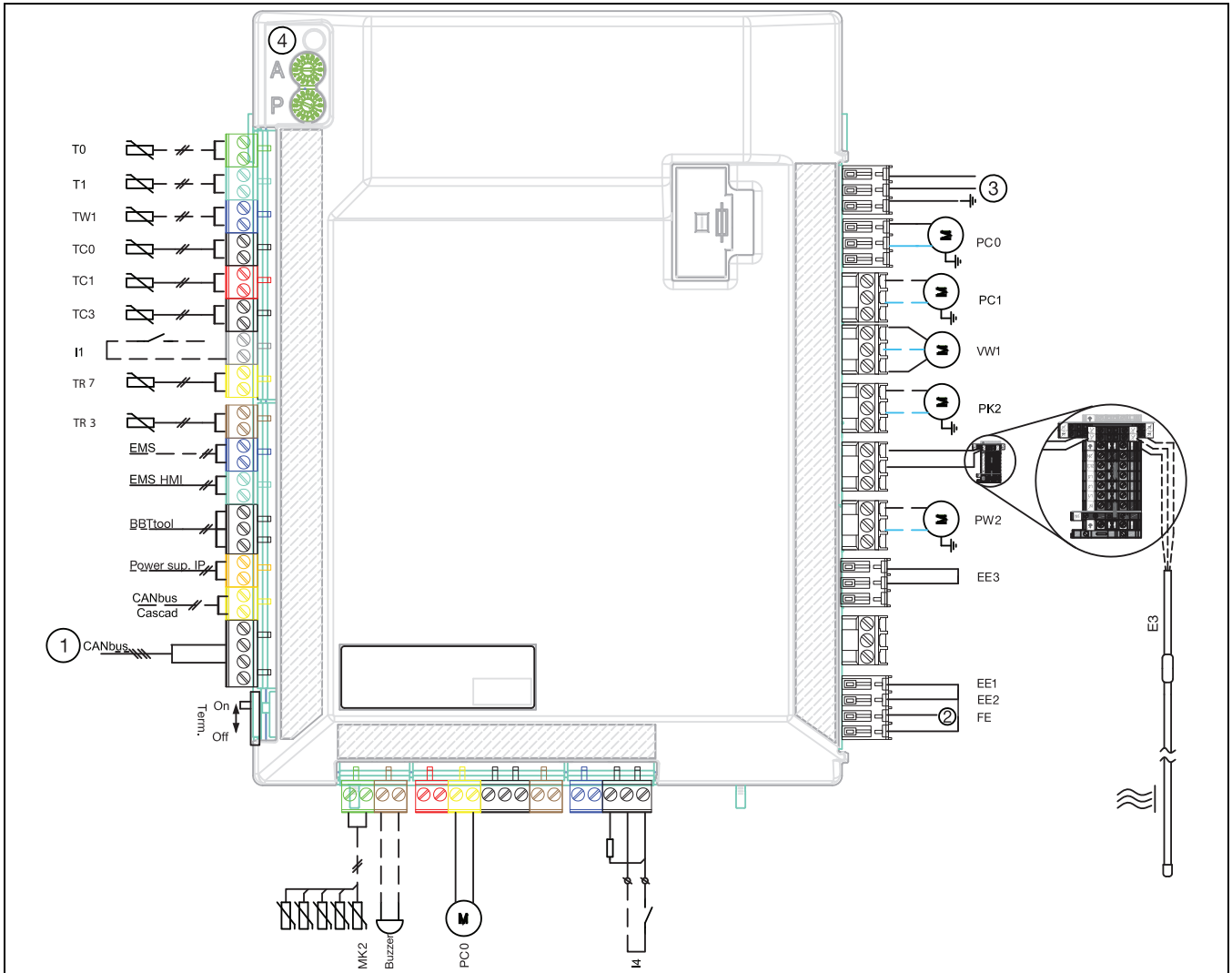

Fig. 12 SEC 20 installer module of indoor unit with electric heater

Continuous line = connection made at the factory

Dotted line = connection made during installation:

- [1] CAN-BUS to outdoor unit
- [2] Alarm electric heater/pressure switch (~230 V input voltage)
- [3] Power supply 230 V ~ 1 N
- [4] Code switch and LED bus communication
- [T0] Flow temperature sensor
- [T1] Outside temperature sensor
- [TW1] DHW sensor
- [TC0] Heat transfer medium in
- [TC1] Heat transfer medium out
- [TC3] Condenser temperature
- [I1] Ex. input
- [TR7] Hot gas temperature sensor
- [TR3] Liquid temperature sensor
- [MK2] Condensation point sensors
- [Buzzer] Alarm sounder (accessory)
- [PC0] Pump primary circuit PWM signal
- [I4] Ex. input
- [EE2] Electric heater, step 2
- [EE1] Electric heater, step 1
- [EE3] Electric heater, step 3
- [PW2] DHW circulation pump
- [E3] Heating cable (HC), accessory (~230 V output)
- [PK2] Heating pump cooling buffer/fan convectors
- [VW1] 3-way diverter valve for DHW (accessory)
- [PC1] Heating pump (heating system)

[PC0] Heating pump (brine pump)



Max load for relay outputs PW2, PK2, VW1, PC1: 2 A, cos φ > 0.4.
Maximum load for CUHP inst.: 6.3 A



Note regarding input I1 (connection 13, 14) and I4 (connection 49, 50).
Contact on the component or relay that is connected to this input must be suitable for 5 V and 1 mA.



Note regarding [4]:
Coding switches A and P must not be adjusted! Otherwise malfunctions and faults will occur.
Important: check the coding when a replacement part is used.

5.7.9 Connection alternative for EMS bus

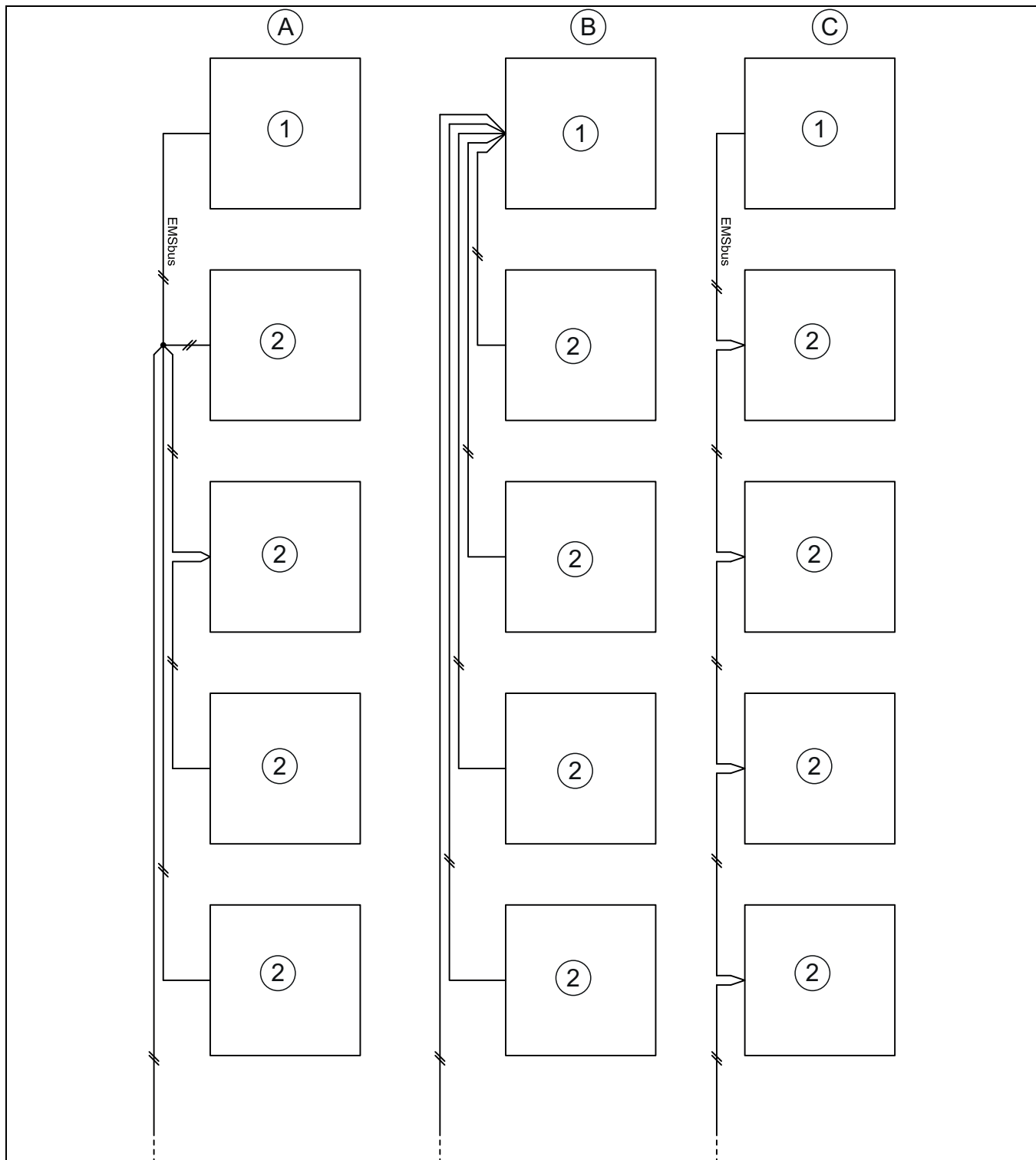

Fig. 13 Connection alternative for EMS bus

- [A] Star configuration and connection in series with external junction box
- [B] Star configuration
- [C] Serial connection
- [1] Installation circuit board
- [2] Accessory modules (room temperature-dependent controller, heating circuit module and solar module)

6 Commissioning

6.1 Venting the indoor unit

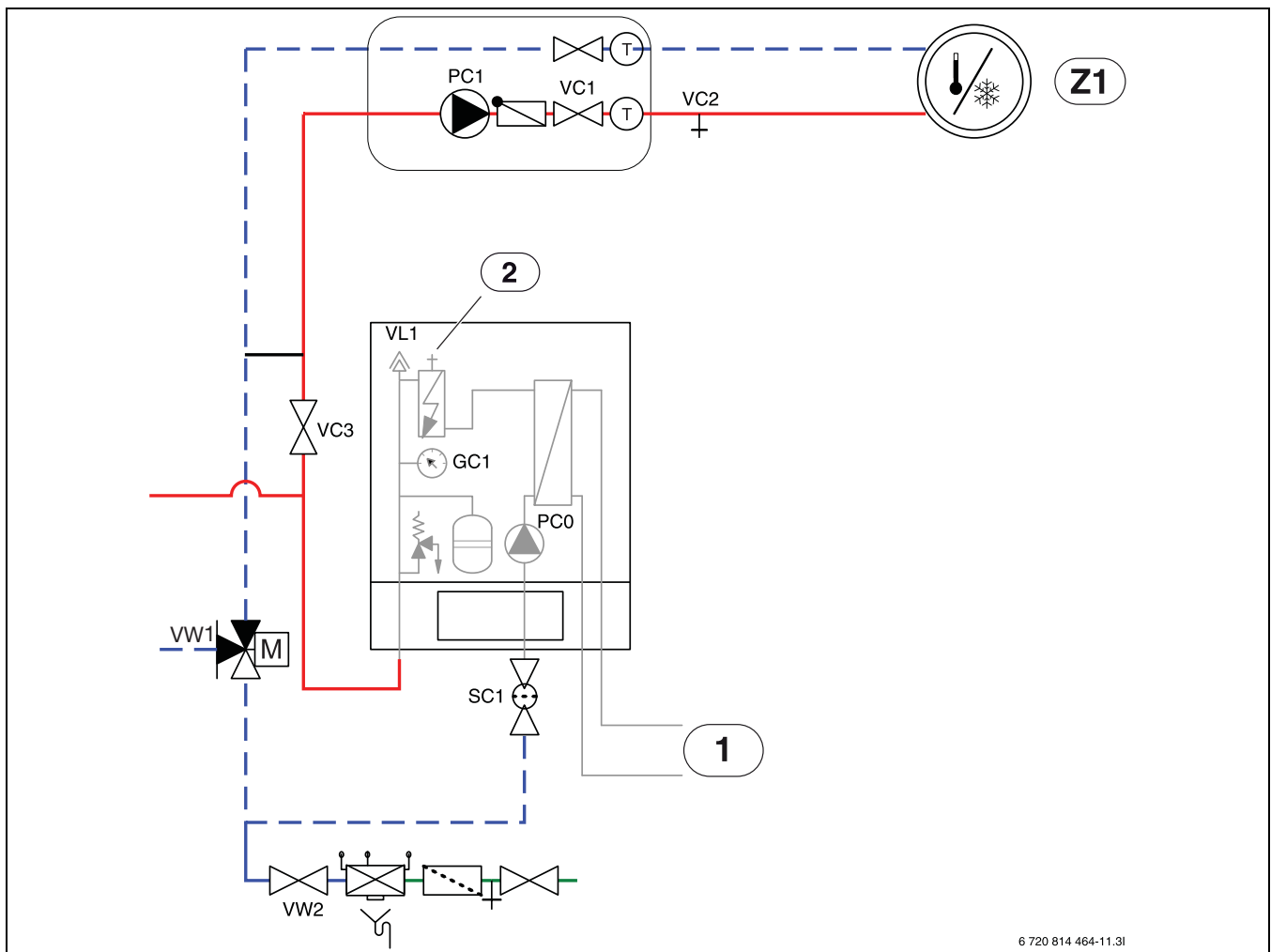

Fig. 14 Indoor unit with internal immersion heater and heating system

- [Z1] Heating system (without mixing valve)
- [1] Heat pump, outdoor unit
- [2] Manual air vent valve
- [PC0] Heating pump
- [VC2] Drain valve
- [VC3] Valves for the heating system
- [VL1] Automatic air vent valve
- [GC1] Pressure gauge
- [SC1] Water/air filter
- [VW1] 3-way mixing valve
- [VW2] Fill valve

See fig. 14:

1. Connect the power supply to the heat pump and indoor unit.
2. Activate "Only auxiliary heater" and make sure that the heating pump PC1 is running.
3. Remove the pulse width modulation plug PC0 from the heating pump PC0 so that it can operate at maximum speed.
4. Deactivate the "Only auxiliary heater" function when no more air is coming out of the VL1 or the manual air vent valve on top of the electric heater. Close the manual air vent valve.
5. Connect the PC0 pulse width modulation plug to the heating pump.
6. Clean the particle filter SC1.
7. Also vent via the other air vent valves of the heating system (e.g. radiators).

8. Check the pressure on the pressure gauge GC1 and top up with the fill valve VW2 if needed. The pressure should be 0.3–0.7 bar above the pressure set in the expansion vessel.
9. Check that the heat pump is running and that there are no alarms.

6.2 Adjusting the operating pressure of the heating system

Display on the pressure gauge	
1 bar	Minimum charge pressure. When the system is cold, the operating pressure must be kept at roughly 0.2–0.5 bar above the pre-charge pressure of the nitrogen cushion in the expansion vessel. The pre-charge pressure is 0.7–1.0 bar as a rule.
3 bar	Maximum charging pressure at maximum heating water temperature: must not be exceeded (the pressure relief valve will open).

Table 5 Operating pressure

- ▶ Top up to 1.5–2.0 bar unless otherwise specified.
- ▶ If the pressure does not remain constant, check whether the heating system has any leaks and if the capacity of the expansion vessel for the heating system is sufficient.

6.3 Pressure switch and overheating protection



The pressure monitor and overheating protection are only installed in indoor units with integrated electric booster heater.

The pressure switch and overheating protection are connected in series. Alarms or information triggered at the control unit indicate either that the operating pressure is too low, or that the temperature of the electric booster heater is too high.

NOTICE:

Material damage from running dry!

When the heating pump PC0 is operated for a long time when the operating pressure is too low, it can be damaged.

- ▶ Eliminate any leaks in the system that are indicated when the pressure switch is triggered.



The triggering of the pressure switch only blocks the electric booster heater. The heating pump PC0 and the outdoor unit can continue to run if there is a risk of frost.

Pressure switch

The indoor unit has a pressure switch which triggers once the pressure in the heating system falls below 0.5 bar. Once the pressure exceeds 0.5 bar, the pressure switch is automatically reset.

- ▶ Make sure that the expansion vessel and pressure relief valve are configured for the indicated operating pressure, and check whether an additional expansion vessel is necessary in the system.
- ▶ Check the system for leaks, and use a larger expansion vessel if necessary.
- ▶ Slowly increase the pressure in the heating system by adding water through the fill valve.

Overheating protection

The overheating protection triggers when the temperature of the electric booster heater rises above 95 °C.

- ▶ Check the operating pressure.
- ▶ Check the heating and DHW settings.
- ▶ Reset the overheating protection. To do this, press the button on the bottom of the terminal box. (→ [13], fig. 2).

6.4 Function test

- ▶ Start the system according to the instructions for the control unit.
- ▶ Vent the system according to chapter 6.1.
- ▶ Test the active components of the system as described in the instructions for the control unit.
- ▶ Check if the start conditions have been met for the outdoor unit.
- ▶ Check if there is a heating or hot water demand.

-or-

- ▶ Draw off DHW or increase the heating curve to generate demand (if necessary, adjust the setting for **Heating mode down** if the outside temperature is high).
- ▶ Check if the outdoor unit starts.
- ▶ Make sure that there are no current alarms (see control unit instructions).

-or-

- ▶ Eliminate any faults according to the control unit instructions.
- ▶ Check the operating temperatures in accordance with the instructions for the control unit.

6.4.1 Operating temperatures



The operating temperature check must be performed in heating mode (not in DHW or cooling mode).

For optimum system operation, the flow rate in the heat pump and heating system must be monitored. This check should be performed after 10 minutes heat pump operating time and during high compressor heating output.

The temperature differential for the heat pump must be set for the different heating systems.

- ▶ With underfloor heating system 5 K as temp.diff. Setting heating.
- ▶ With radiators 8 K as temp.diff. Setting heating.

These settings are optimal for the heat pump.

Check the temperature differential at high compressor heating output:

- ▶ Open the diagnosis menu.
- ▶ Select Monitored values.
- ▶ Select Heat pump.
- ▶ Select Temperatures.
- ▶ Read the primary flow temperature (heat transfer medium off, sensor TC3) and return temperature (heat transfer medium on, sensor TCO) in heating mode. The flow temperature must be higher than the return temperature.
- ▶ Calculate the difference TC3–TC0.
- ▶ Check whether the difference corresponds to the delta value set for heating mode.

If the temperature differential is too large:

- ▶ Vent the heating system.
- ▶ Clean filters / strainers.
- ▶ Check pipe dimensions.

Temperature differential in the heating system

- ▶ Set the output at the heating pump PC1 so that the following difference is achieved:
- ▶ With underfloor heating system: 5 K.
- ▶ With radiators 8 K.

7 Maintenance



DANGER:

Electrical shock!

- ▶ Before working on the electrics, the main power supply must be switched off.

NOTICE:

Deformation due to heat!

If the temperature is too high, the insulation (EEP) in the indoor unit deforms.

- ▶ When carrying out welding work in the heat pump, protect the insulation with a heat resistant cloth or damp cloth.

- ▶ Only use genuine spare parts!
- ▶ Refer to the spare parts list when ordering spare parts.
- ▶ Replace removed gaskets and O-rings with new ones.

The tasks described below must be carried out during an inspection.

Display activated alarm

- ▶ Check the alarm log (→ instructions for the control device).

Function test

- ▶ Carry out function check (→ Chap. 6.4).

Install power cable

- ▶ Check the power cable for mechanical damage. Replace damaged cables.

7.1 Particle filter

The filter prevents particles and contamination from entering the heat pump. Over time, the filter can become blocked and must be cleaned.



To clean the filter, the system does not need to be emptied. The filter is integrated into the shut-off valve.

Cleaning the strainer

- ▶ Close the valve (1).
- ▶ Unscrew the cap (manually) (2).
- ▶ Take out the strainer and clean it by running water over it or by pressure cleaning.
- ▶ Reinstall the strainer. For proper assembly, make sure that the guide bumps fit into the recesses in the valve.

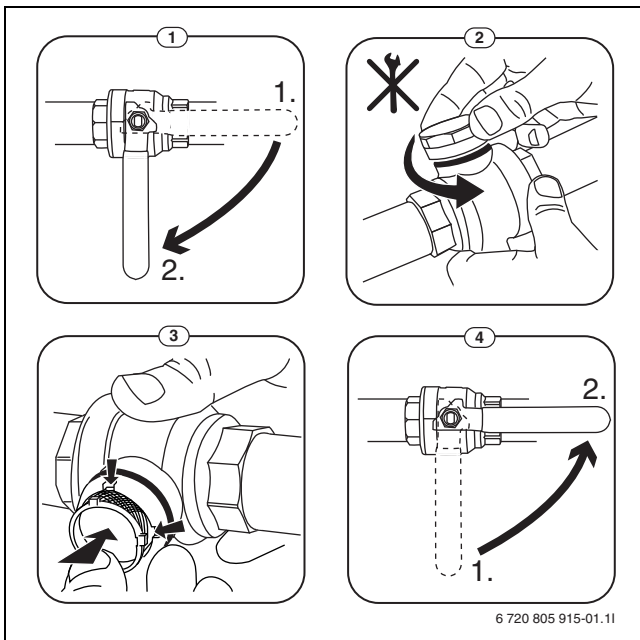

Fig. 15 Cleaning the strainer

- ▶ Screw the cap back on (tighten handtight).
- ▶ Open the valve (4).

Check the magnetite indicator

After installation and startup the magnetite indicator must be checked at more frequent intervals. If a lot of magnetic dirt is clinging to the magnetic bar in the particulate filter and that dirt frequently causes an alarm related to the poor flow (e.g., low or poor flow, high flow supply or HP alarm) a magnetite filter (see list of accessories) must be installed to avoid regular draining of the indicator. A filter also increases the longevity of components in the heat pump as well as the remaining parts of the heating system.

8 Installation of accessories

8.1 Temperature controller (accessory, see separate instructions)



If the temperature controller is installed after commissioning the system, it must be set in the commissioning menu as control unit for the corresponding heating circuit (→ instructions for the control unit).

- ▶ Before commissioning the system, make the setting for the heating circuit at the temperature controller, if required (→ instructions for temperature controller).
- ▶ When commissioning the system, specify that a temperature controller is installed as control unit for heating circuit 1 (→ instructions for the control unit).
- ▶ Set the room temperature as specified in the instructions for the control unit.

If a component is already connected to the EMS terminal, connect in parallel to the same terminal according to fig. 16. If several EMS modules are installed in the system, connect them according to fig. 13, chapter 5.7.9.

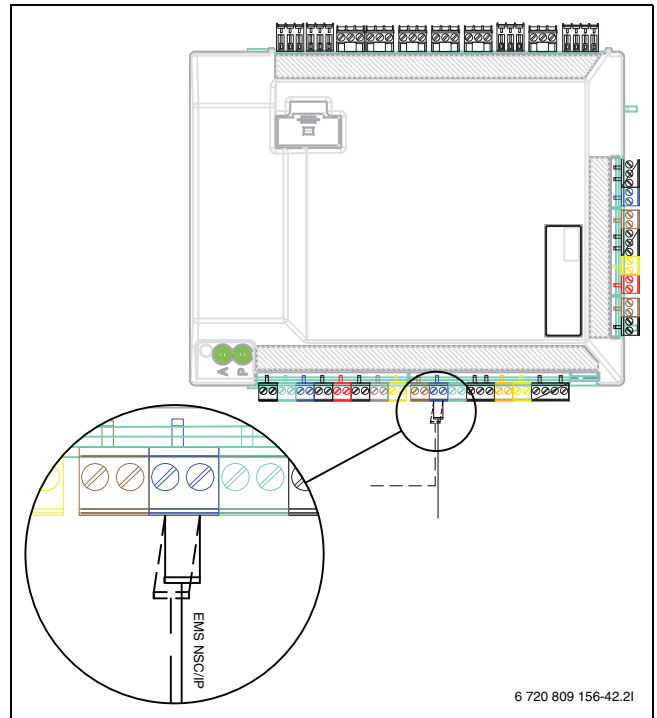

Fig. 16 EMS connection on the installer module

8.2 External inputs

Route all low voltage cables (measuring current) separately from cables carrying 230 V or 400 V to avoid inductive interference (minimum separation of 100 mm).

When extending temperature sensor cables, use the following conductor diameters:

- Cable up to 20 m in length: 0.75 to 1.50 mm²
- Cable up to 30 m in length: 1.0 to 1.50 mm²

The relay output PK2 is active in cooling mode and can be used to control the cooling/heating mode of a fan convector or a heating pump, or to control underfloor heating circuits in humid rooms.



Maximum load at relay outputs: 2 A, $\cos\phi > 0.4$. If the load is higher, it will be necessary to use an intermediate relay.



WARNING:

Material damage from incorrect connection!

The electrical components may become damaged if connected to the wrong voltage or current.

- ▶ Only make connections that are adapted for 5 V and 1 mA to the external connections of the indoor unit.
- ▶ If coupling relays are required, only use relays with gold contacts.

8.3 Installation of the domestic hot water cylinder



If the domestic hot water cylinder is installed lower than the heat pump (e.g. in the cellar), a natural circulation can occur that leads to heat loss in the cylinder.

- ▶ Install a non-return valve in the circuit to prevent natural circulation if the installation height of the domestic hot water cylinder is below the heat pump.

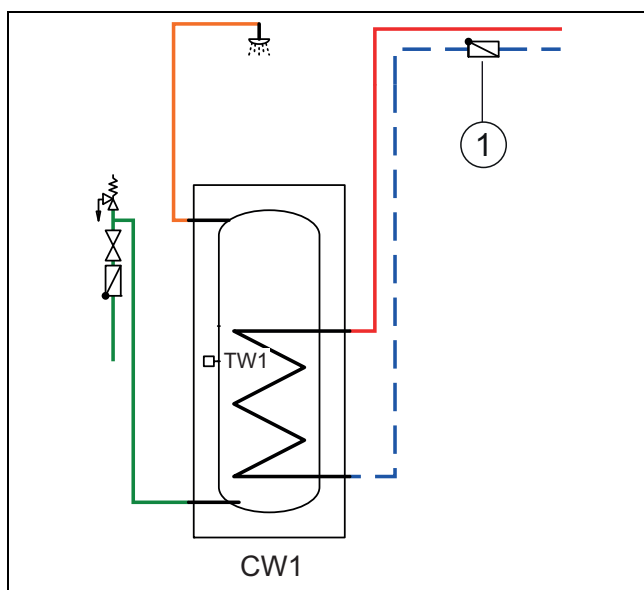

Fig. 17 Hot water cylinder

[1] Non-return component



The connection instructions are in the cylinder documentation.



When using a DHW cylinder (circuit flow cylinder) in the heating system, an automatic air vent valve must be mounted on the cylinder. This also applies to twin wall cylinders.



When using a circuit flow cylinder in the heating system, an automatic air vent valve must be installed at the inlet to the cylinder with a micro-bubble separator.

8.4 DHW cylinder temperature sensor TW1

When a DHW cylinder is connected and TW1 is connected to the system, this is automatically actuated upon starting.

- ▶ Connect the hot water temperature sensor TW1 on the installation module in the control device to terminal TW1.

8.5 Diverter valve VW1

System solutions with a domestic hot water cylinder require a diverter valve (VW1). Connect the diverter valve VW1 on the installer module in the indoor unit to terminal VW1 (fig. 18).

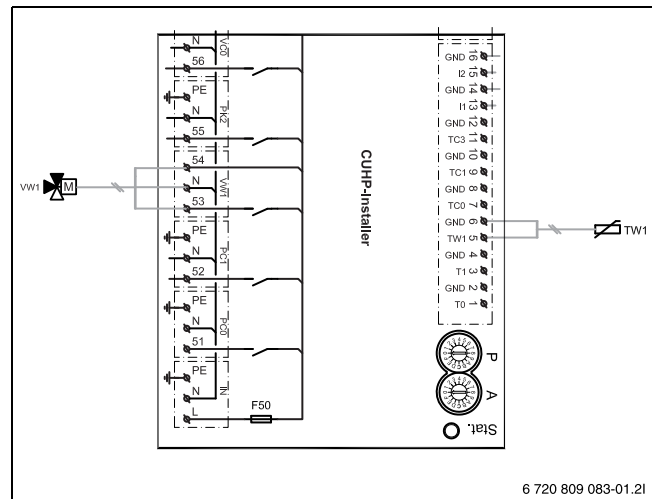

Fig. 18

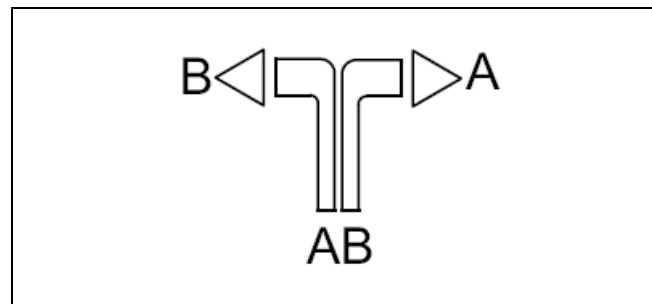

Fig. 19

- [A] To the domestic hot water cylinder
- [B] To the heating system (or buffer cylinder)
- [AB] From the indoor unit

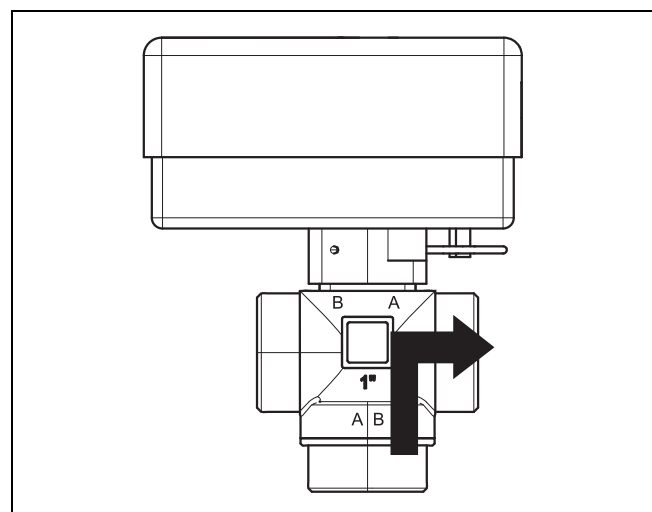

Fig. 20 Contact closed, connection A open

During domestic hot water heating, the contact is closed and connection A is open.

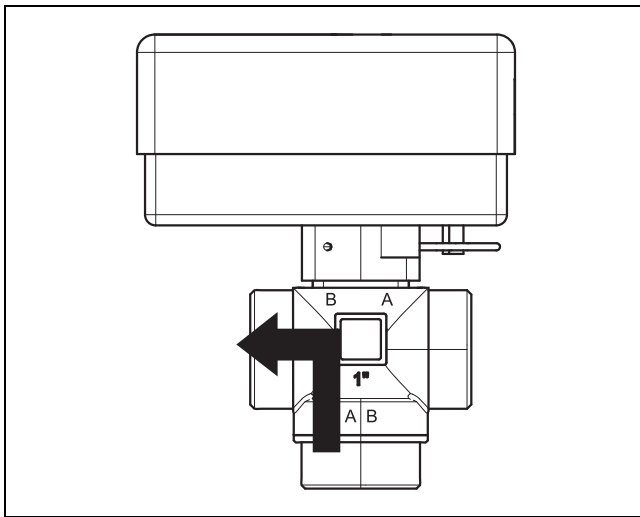

Fig. 21 Contact open, connection B open

In heating mode, the contact is opened and connection B is open.

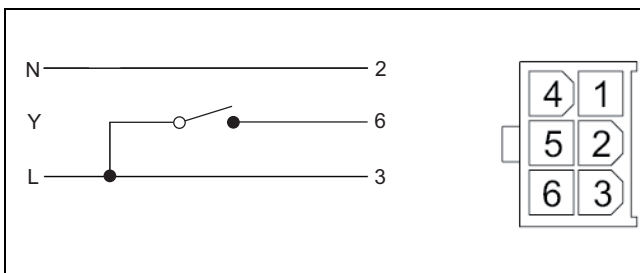

Fig. 22 Molex plug

The 3-way diverter valve has a Molex plug in which only terminals 2, 3 and 6 are assigned.

Make the following connections on the installation module:

- ▶ N – Connection to terminal N, VW1 on the installation module
- ▶ N – Connection to terminal 53, VW1 on the installation module
- ▶ N – Connection to terminal 54, VW1 on the installation module

8.6 Several heating circuits (with heating circuit module)

In the delivery ex works, a heating circuit without mixer can be controlled via the controller. If other circuits are to be installed, a heating circuit module is required for each one.

- ▶ Install the heating circuit module, mixer, heating pump and other components according to the selected system solution.
- ▶ Connect the heating circuit module on the installer module in the control device of the indoor unit to terminal EMS.
- ▶ Perform the settings for several heating circuits according to the instructions for the control unit.

8.7 DHW circulation pump PW2 (accessory)

The pump settings are made on the control unit of the indoor unit (→ instructions of the control unit).

8.8 Installation with cooling

NOTICE:

Material damage due to moisture!

Only the indoor unit with integrated electric booster heater is sufficiently insulated against condensation for cooling mode below the dew point.



A room temperature-dependent control unit (accessory) must be installed for the cooling mode.



Installing room temperature-dependent control units with an integrated humidity sensor (accessory) increases the safety of cooling mode since the flow temperature in this case is automatically controlled by the control unit corresponding to the current dew point.

- ▶ Insulate all connections and pipes from condensation.
- ▶ Install the room temperature-dependent controller with integrated humidity sensor (→ instructions for the respective room temperature-dependent controller).
- ▶ Install the condensation point sensors (→ Chapter 8.9).
- ▶ Select automatic mode for heating/cooling (→ instructions for control unit).

8.9 Installing the condensation point sensors (accessory for cooling mode)

NOTICE:

Material damage due to moisture!

If the system is operated below the dew point in cooling mode, this causes moisture to precipitate on adjacent materials (floor).

- ▶ Do not operate underfloor heating systems in cooling mode below the dew point.
- ▶ Set the correct flow temperature.

The condensate monitoring function stops the cooling mode when condensate formation is detected on the pipes of the heating system. Condensate forms in cooling mode when the temperature of the heating system is below the corresponding dew point temperature.

The dew point will vary depending on temperature and humidity. The higher the humidity, the higher the flow temperature must be to remain above dew point and avoid condensation.

The humidity sensors send a signal to the control once they detect condensate formation. This stops cooling mode.

Installation and handling instructions are supplied with the dew point sensors.

8.10 Installation with swimming pool

NOTICE:

Danger of faults!

If the swimming pool mixer is installed in the wrong location in the system, faults may occur. The swimming pool mixer must not be installed in the flow where it could block the pressure relief valve.

- ▶ Assemble the swimming pool mixer in the return to the indoor unit (as shown in the example image for swimming pool installation).
- ▶ Mount the tee connection piece in the flow from the indoor unit upstream of the bypass.
- ▶ Do not install the swimming pool mixer as heating circuit in the system.



A prerequisite for using the swimming pool heating is the installation of a swimming pool module (accessory).

- ▶ Installing the swimming pool mixer.

- ▶ Insulate all pipes and connections.
- ▶ Install the pool module (→ Instructions for the pool module).
- ▶ Set the elapsed time of the swimming pool diverter valve during commissioning (→ instructions of control unit).
- ▶ Make the necessary settings for the swimming pool mode (→ instructions for control unit).

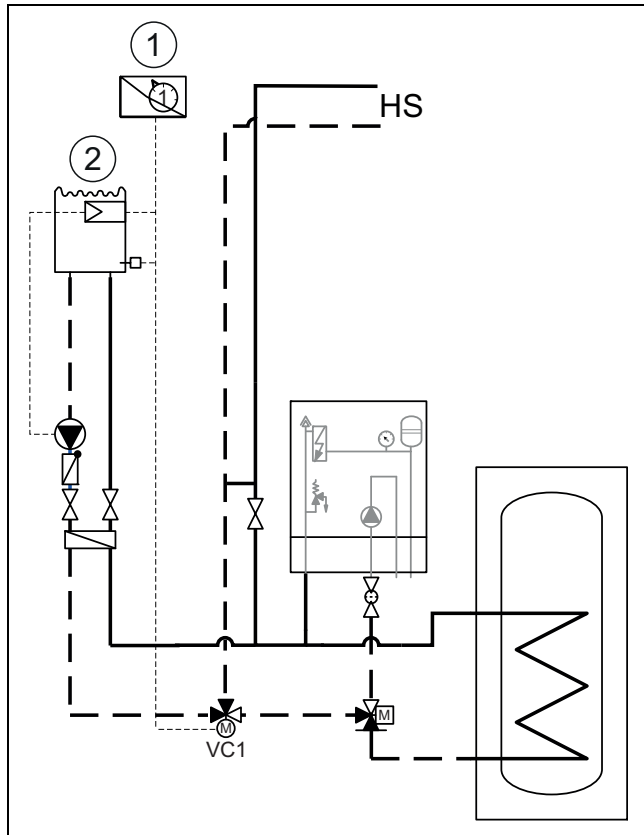

Fig. 23 Example showing swimming pool installation

- [1] Swimming pool module
- [2] POOL
- [VC1] Swimming pool mixer
- [HS] Heating system

8.11 Cooling only with fan convectors

NOTICE:

Material damage due to moisture!

Without full insulation against condensation, moisture can attack neighbouring materials.

- ▶ In cooling mode, all pipes and connections up to the fan convector should be provided with condensation insulation.
- ▶ Use an insulating material designed for cooling systems with condensate formation (Armaflex).
- ▶ Connect the outlet to the drain.
- ▶ In cooling mode below the dew point, do not use condensation point sensors.

8.12 IP module

 The IP module is installed as standard in a number of products and can be retrofitted to others as an accessory.

 To take advantage of all the functions, an Internet connection and router with a free RJ45 output are necessary. This can lead to additional costs. The **Bosch EasyRemote** app is required to control the system using a mobile phone.

The IP module can be used to control and monitor the system via a mobile device. It is used as an interface between the heating system and a network (LAN) and also enables the SmartGrid function.

Commissioning

 When commissioning, refer to the router documents.

The router must be configured as follows:

- DHCP active
- Ports 5222 and 5223 must not be blocked from outgoing traffic.
- Free IP address available
- Address filtering adapted to the module (MAC filter).

The following options exist for commissioning the IP module:

- Internet

The IP module automatically obtains an IP address from the router. The name and address of the target server are stored in the factory settings of the module. Once an Internet connection is established, the IP module automatically logs on to the BOSCH server.

- LAN

The module does not have to have Internet access. It can also be used in a local network. In this case, the heating system cannot be accessed through the Internet, and the IP module software is not automatically updated.

- App **Bosch EasyRemote**

When starting the app for the first time, you will be asked to enter the login name and password set at the factory. These login details are printed on the data plate of the IP module.

- SmartGrid

With SmartGrid, the indoor unit can communicate with the energy exchange and modify the operation of the heat pump so that it is at the maximum output when the price for the power is the most affordable. For details of the SmartGrid, refer to the website of the energy supplier.

 The login data are lost when the IP module is exchanged.

Each IP module has its own login data.

- ▶ After commissioning, enter the login data in the corresponding field of the user instructions.
- ▶ After exchanging, replace with the data for the new IP module.

 Alternately, the password can be changed at the control device.

Login data for the IP module

Manuf. no.: _____
 Login name: _____
 Password: _____
 Mac: _____

9 Operation without the outdoor unit (individual operation)

The indoor unit can be started without the outdoor unit being connected, for example if the outdoor unit is to be installed at a later date. This is termed individual operation or stand-alone operation.

With individual operation, the indoor unit only uses the integrated or external auxiliary heater for heating and DHW heating.

Commissioning in individual operation:

- ▶ In the «Heat pump» service menu, select the option «**Individual operation**» (→ instructions for the control unit).

10 Environmental protection and disposal

Environmental protection is a fundamental corporate strategy of the Bosch Group.

The quality of our products, their economy and environmental safety are all of equal importance to us and all environmental protection legislation and regulations are strictly observed.

We use the best possible technology and materials for protecting the environment taking account of economic considerations.

Packaging

Where packaging is concerned, we participate in country-specific recycling processes that ensure optimum recycling.

All of our packaging materials are environmentally compatible and can be recycled.

Used appliances

Used appliances contain valuable materials that can be recycled.

The various assemblies can be easily dismantled. Synthetic materials are marked accordingly. Assemblies can therefore be sorted by composition and passed on for recycling or disposal.

Old electrical and electronic appliances



This symbol means that the product must not be disposed of with other waste, and instead must be taken to the waste collection points for treatment, collection, recycling and disposal.

The symbol is valid in countries where waste electrical and electronic equipment regulations apply, e.g. "European Directive 2012/19/EC on old electronic and electrical appliances". These regulations define the framework for the return and recycling of old electronic appliances that apply in each country.

As electronic devices may contain hazardous substances, it needs to be recycled responsibly in order to minimize any potential harm to the environment and human health. Furthermore, recycling of electronic scrap helps preserve natural resources.

For additional information on the environmentally compatible disposal of old electrical and electronic appliances, please contact the relevant local authorities, your household waste disposal service or the retailer where you purchased the product.

You can find more information here:

www.weee.bosch-thermotechnology.com/

11 Technical information

11.1 Specifications – Indoor unit with electric booster heater

AWES	Unit	2-6	8	11-15
Electrical wiring specifications				
Power supply	V	400 ²⁾ /230 ¹⁾	400 ²⁾ /230 ¹⁾	
Recommended fuse size ³⁾	A	3 x 16 ²⁾ /50 ¹⁾	3 x 16 ²⁾ /50 ¹⁾	
Connected load	KW	2/4/6/9	2/4/6/9	
Heating system				
Connection type (heating flow)		1" male thread	1" male thread	
Type of connection (heating return)		1" female thread	1" female thread	
Connection type for the heat pump flow (gas)		5/8"	5/8"	
Connection type for the heat pump return (liquid)		3/8"	3/8"	
Maximum operating pressure	kPa/bar	300/3.0	300/3.0	
Minimum operating pressure	kPa/bar	50/0.5 ⁴⁾	50/0.5 ⁴⁾	
expansion vessel	l	8	8	
Available external pressure	kPa/bar	56/0.56	73/0.73	58/0.58
Minimum flow (during defrosting) ⁵⁾	l/s	0.34	0.34	0.47
Pump type		Grundfos UPM2K 25-75 PWM	Grundfos UPM GEO 25-85 pulse width modulation	
General Information				
Installation altitude		up to 2000 m over NN		
IP rating		IPX1		
Dimensions (width x depth x height)	mm	485 x 398 x 700		
Weight	kg	41	44	

1) 1N AC 50 Hz. The outdoor unit must have a separate power supply

2) 3N AC 50 Hz, standard version for Germany

3) Fuse characteristic gL/C

4) Pressure depending on the pressure in the expansion vessel

5) If the minimum flow rate in the system cannot be ensured, a buffer cylinder is essential.

Table 6 Indoor unit with electric booster heater

11.2 System solutions



The outdoor unit and the indoor unit may only be installed according to the manufacturer's official system solutions.

Deviating system solutions are impermissible. Liability is voided in the case of damage and problems resulting from impermissible installation.

11.2.1 Explanations of the system solutions

	General
SEC 20	Installer module integrated in the indoor unit
HPC 400	User interface
CR10H	Room temperature-dependent control unit with air humidity sensor (accessory)
T1	Outdoor sensor
MK2	Humidity sensor (accessory)
CW1	DHW cylinder (accessory)
VW1	Diverter valve (accessory)
PW2	DHW circulation pump (accessory)
TW1	Hot water temperature sensor

Table 7 General Information

Z1	Heating circuit without mixer
PC1	Circulation pump, heating circuit
T0	Flow temperature sensor

Table 8 Z1

11.2.2 Bypass of the heating system

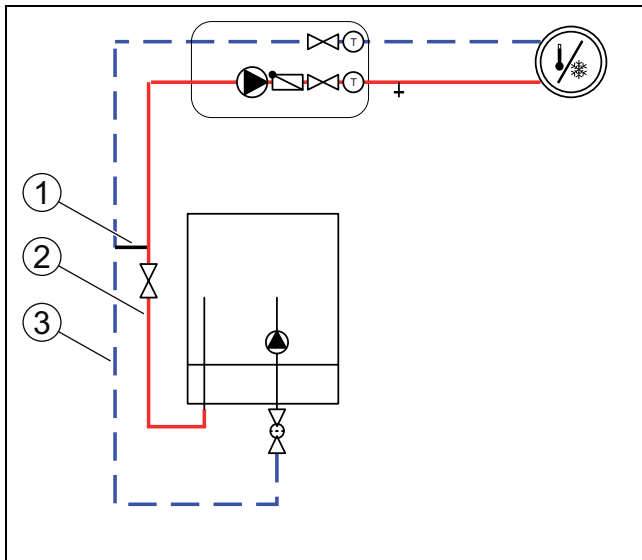

Fig. 24 Indoor unit with heating circuit and bypass

- [1] Bypass (→ fig. 26) (→ [1] Tab. 9)
- [2] Flow pipe diameter (→ [2] Tab. 9)
- [3] Return pipe diameter (→ [3] Tab. 9)

Some system configurations require accessories (buffer cylinder, 3-way valve, mixing valve, DHW circulation pump). If a heating circuit pump (PC1) is installed, this is controlled by the controller in the indoor unit.

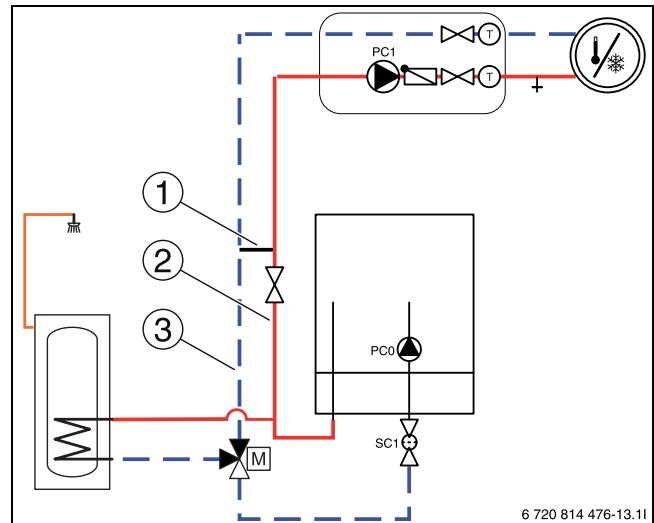
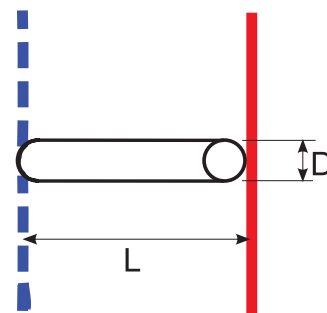

Fig. 25 Indoor unit with heating circuit and DHW heating

- [1] Bypass (→ fig. 26) (→ [1] Tab. 9)
- [2] Flow pipe diameter (→ [2] Tab. 9)
- [3] Return pipe diameter (→ [3] Tab. 9)



6 720 810 933-12.3T

Fig. 26 Bypass details (→ [1] [AWES fig. 24 and 25])

- [L] Minimum bypass length
- [D] Piping diameter



The bypass must have an outer pipe diameter of 22 mm (Cu) and be installed between the supply and return. The bypass must be installed close to the indoor unit (AWES), and no more than 1.5 m away from it.

HP of outdoor unit	([2] and [3] → fig. 24 [AWES] and 25) external flow/return pipe diameter	([1] → fig. 24 and 25) external bypass pipe diameter ([D] → fig. 26)	Bypass design	
	mm	mm	([A] → fig. 27) Minimum bypass length ([L] → fig. 26) mm	([B] → fig. 27) Minimum bypass length ([L] → fig. 26) mm
2-8	22	22	200	100
11-15	28	22	200	100

Table 9 Pipe diameter and bypass lengths

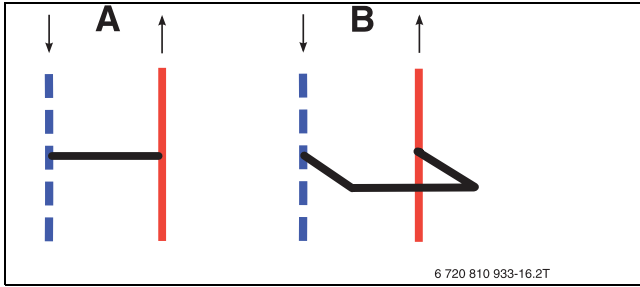

Fig. 27 Bypass

- [A] Bypass, straight design
- [B] Bypass, U-shaped design

11.2.3 System solution with heat pump and indoor unit with integrated immersion heater

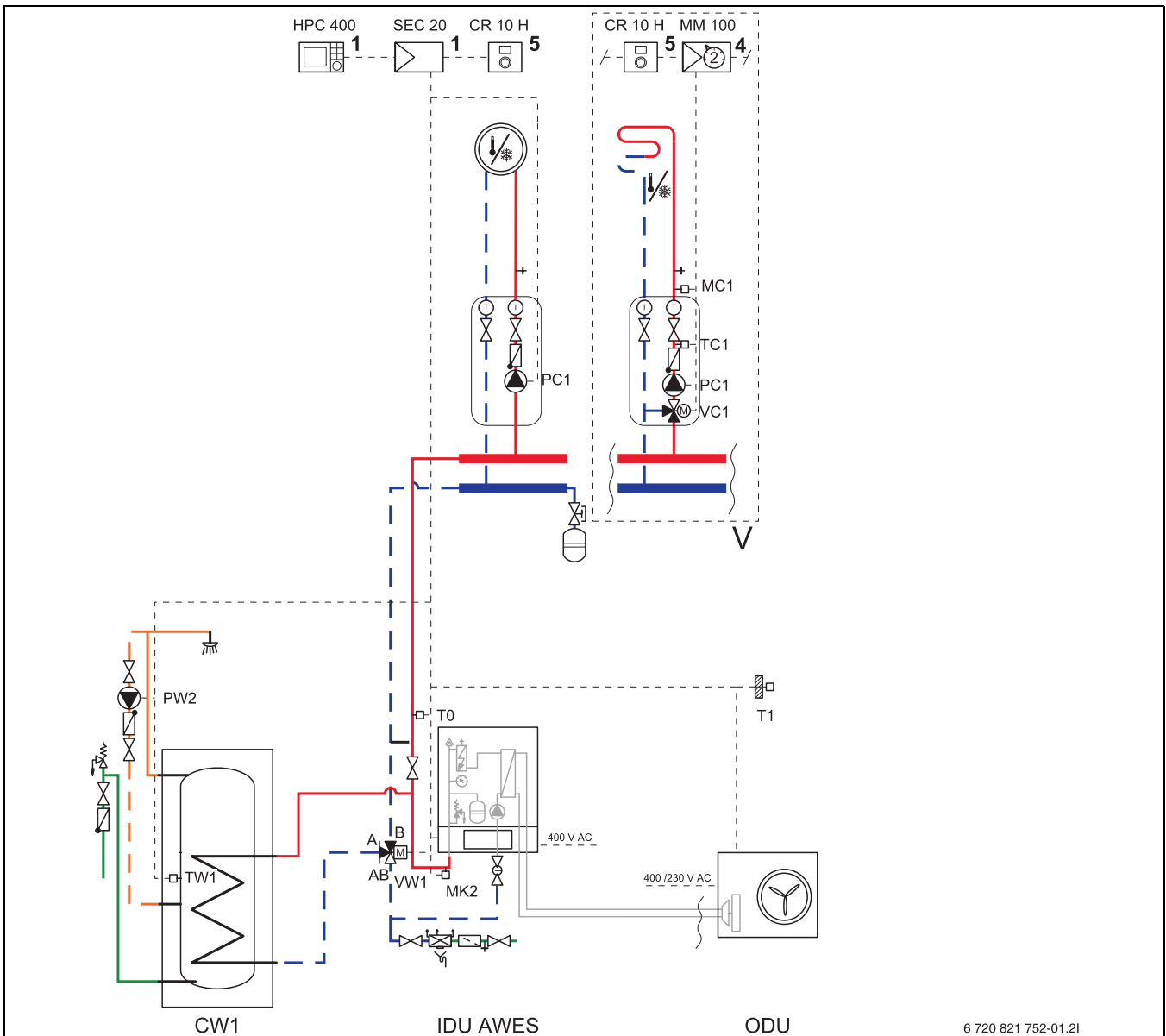

Fig. 28 Auxiliary heater with mixer and domestic hot water cylinder

- [1] On the heat/cooling source
- [4] In the station or on the wall
- [5] On the wall
- [V] Variants (up to 4 heating/cooling circuits in total)



For further hydraulic systems, see the technical guide.

11.2.4 Explanation of symbols

Symbol	Description	Symbol	Description	Symbol	Description
Pipework/cables					
	Flow - heating/solar		Brine return		DHW circulation
	Return - heating/solar		Potable water		Electrical Wiring
	Brine flow		Hot water		Electrical wiring with break
Mixing valves/valves/temperature sensors/pumps					
	Valve		Differential pressure regulator		Pump
	Revision bypass		Pressure Relief Valve		Non-return valve
	Flow regulating valve		Safety assembly		Temperature sensor / switch
	Overcurrent valve		3-way mixing valve (mixing/distribution)		Safety temperature limiter
	Filter shut-off valve		DHW mixer, thermostatic		Flue gas temperature sensor/ switch
	Cap valve		3-way mixing valve (changeover)		Flue gas temperature limiter
	Valve, motorized		3-way mixing valve (change over, de-energised when closed to II)		Outdoor sensor
	Valve, thermal		3-way mixing valve (change over, de-energised when closed to A)		Wireless outside temperature sensor
	Shut-off valve, magnetically controlled		4-way mixing valve		...wireless...
Miscellaneous					
	Thermometer		Drain outlet with siphon		Low loss header with sensor
	Pressure gauge		System separation according to EN1717		Heat exchanger
	Filling/draining		Expansion vessel with cap valve		Flow rate measuring device
	Water filter		Magnetite separator		Water sink
	Heat meter		Air separator		Heat. circ.
	DHW outlet		Automatic air vent valve		Underfloor heating circuit
	Relay		Expansion joint		Low loss header
	Immersion heater				

Table 10 Hydraulic symbols

11.3 Wiring diagram

11.3.1 Overview of electrical connections

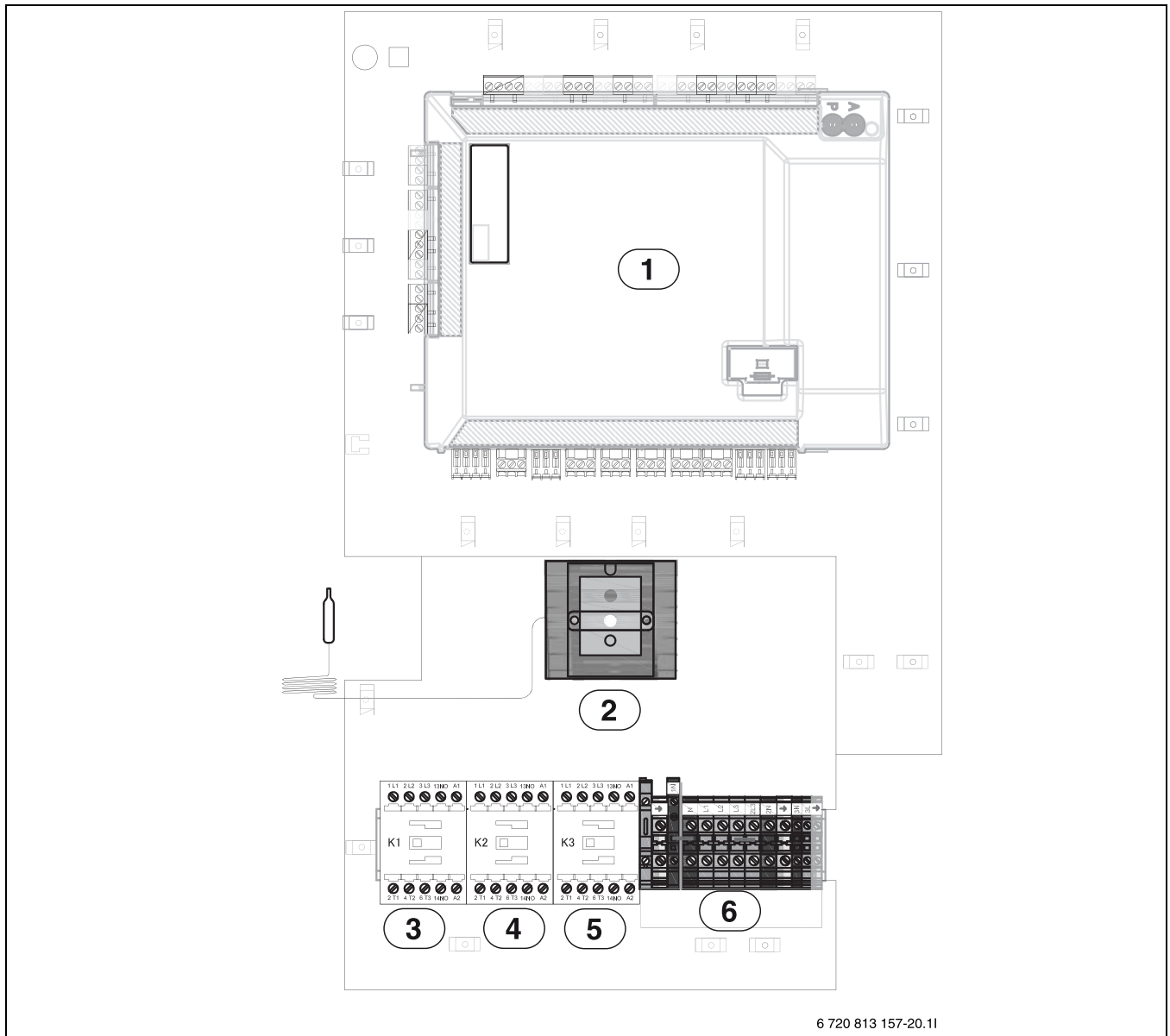

6 720 813 157-20.11

Fig. 29

Continuous line = connection made at the factory

Dashed line = connection made during installation:

- [1] Installation circuit board SEC 20
- [2] Overheating protection (OHP)
- [3] Relay 1 for electric booster heater (2 kW)
- [4] Relay 2 for electric booster heater (4 kW)
- [5] Relay 3 for electric booster heater (3 kW)
- [6] Terminals

11.3.2 CAN & EMS BUS

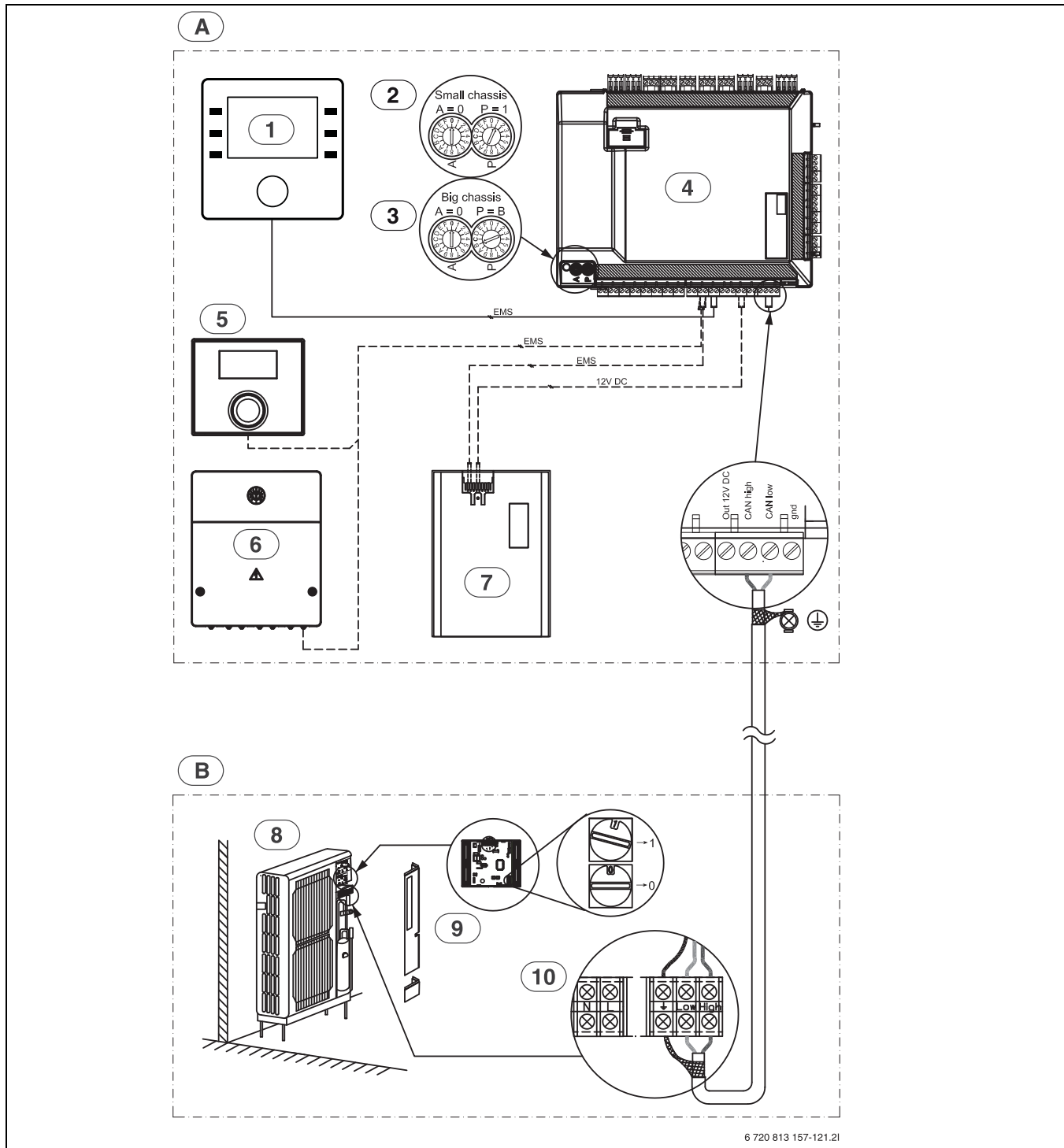

6 720 813 157-121.21

Fig. 30 CAN and EMS connections

Continuous line = connection made at the factory

Dashed line = connection made during installation:

- [A] indoor unit
- [B] outdoor unit
- [1] User interface
- [2] Coding switch setting AWES 2-6
- [3] Coding switch setting AWES 8-15
- [4] Installer module SEC 20
- [5] Room controller (accessories)
- [6] EMS module (accessory)
- [7] IP module (accessory)
- [8] outdoor unit
- [9] CAN interface circuit board
- [10] Outdoor unit terminals

11.3.3 230 V/400 V terminal connections

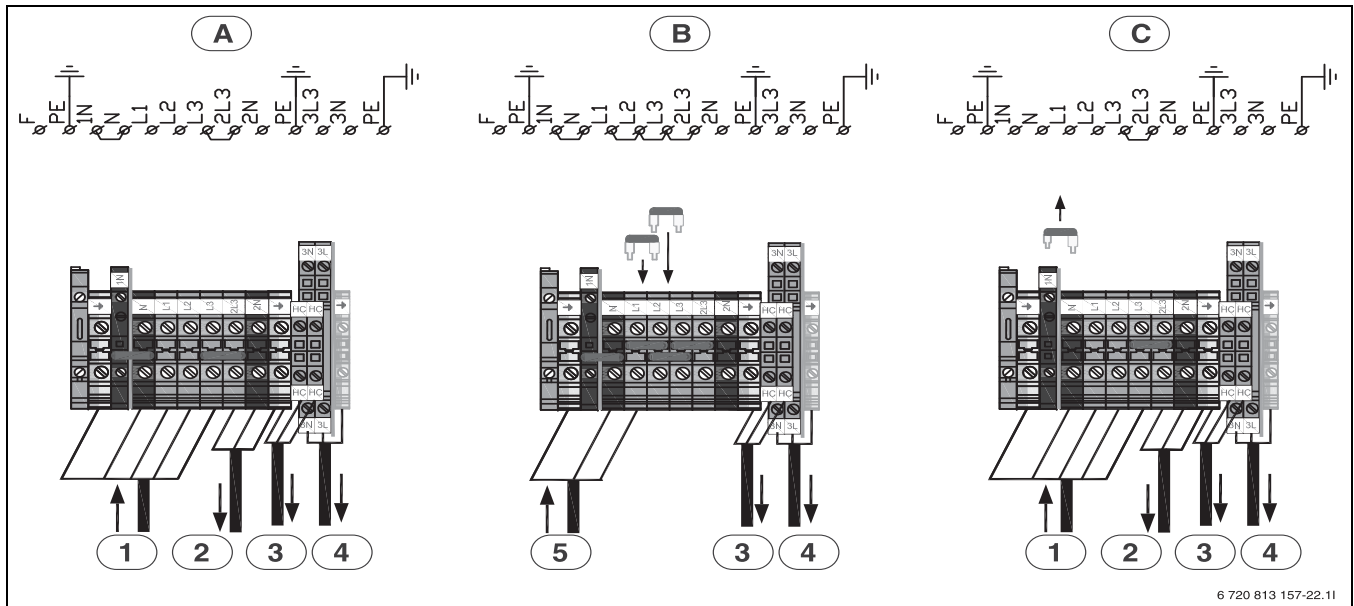

6 720 813 157-22.11

Fig. 31 Terminals

- [A] Delivery condition
- [B] If 1-phase connection is needed, a cross connector/jumper must be installed between (L1, L2 and L3).
- [C] If you remove the cross connector/jumper between (N and 1N) at connection 400 V 3 N~. Output of electric heater, 3 steps:
 - K1 = 1500 W
 - K2 = 3000 W
 - K1 + K2 = 4500 W
 - K1 + K2 + K3 = 9000 W
- [1] 400 V ~3 N power supply
- [2] 230 V ~1 N power supply for single phase heat pump (compressor)
- [3] 230 V ~1 N power supply for heating cable (accessory)
- [4] 230 V ~1 N power supply EMS module (accessory)
- [5] 230 V~1 N power supply

i

Electric heater, 4 steps at 230 V 1 N~ and 400 V 3 N~

K1 = 2000 W
 K2 = 4000 W
 K1 + K2 = 6000 W
 K1 + K2 + K3 = 9000 W

When the compressor is operating, only stages 2000 W, 4000 W or 6000 W are available. The electric heater can only be turned on with 9000 W output when the compressor is turned off.

11.3.5 400 V~ 3N indoor unit with 400 V~ 3N outdoor unit

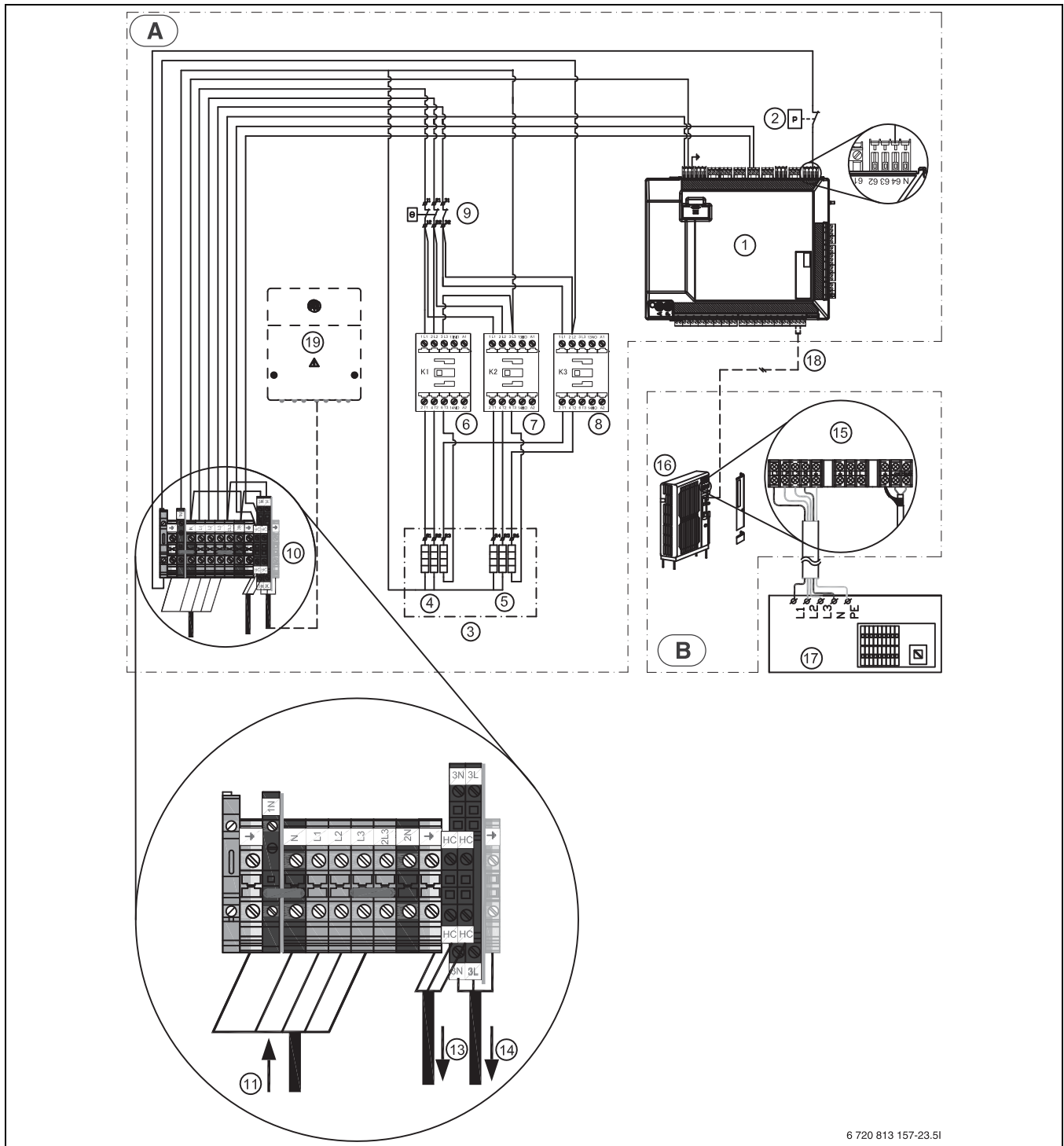

Fig. 33 400 V~ 3N indoor unit with 400 V~ 3N outdoor unit

6 720 813 157-23.5I

- [A] indoor unit
- [B] outdoor unit
- [1] Installer module SEC 20
- [2] Pressure switch
- [3] 9 kW electric heater
- [4] 3x1 kW (3x53 Ω)
- [5] 3x2 kW (3x27 Ω)
- [6] Relay 1 (K1)
- [7] Relay 2 (K2)
- [8] Relay 3 (K3)
- [9] Overheating protection
- [10] Indoor unit terminals
- [11] 400 V ~3 N power supply for indoor unit
- [12] 230 V ~1 N power supply for heating cable
- [13] 230 V ~1 N power supply for EMS (additional)
- [14] 230 V ~1 N power supply for EMS (additional)
- [15] Outdoor unit terminals
- [16] outdoor unit
- [17] 400 V ~3 N power supply for outdoor unit
- [18] Screened CAN bus line 2 x 0.75mm²
- [19] EMS module (accessory)

11.3.6 EVU/SG wiring diagram for the indoor unit with an integrated electric booster heater

11.3.7 Photovoltaic



Since there are only two external inputs for the energy supplier and PV, these cannot be used at the same time.

PV connection to external input 1 or 4.

The heat pump is able to process a control signal of a PV system.

If the PV system has sufficient current for operating the heat pump, it can communicate this information to the heat pump in the form of a start command via a control cable. The control cable must be connected to one of the available external connections. The selected external connection must be configured in the control unit for the PV function.

The heating system must have a buffer cylinder and only heating circuits with a mixer in order for a start command to be effective. A start command causes the buffer cylinder to be charged up to the maximum temperature achievable by the heat pump. However, it can only be charged when the temperature in the buffer cylinder is below the maximum temperature. Otherwise, the heat pump remains off.

11.4 Kabelplan

	Designation	min. cross-section	type of cabel	max. length	connected at:	connection terminal:	Power source
3-way valve	VW1	3 x 1,5mm ²	cable integrated		Indoor unit	53 / 54 / N	IDU
Pump 1. HC	PC1	3 x 1,5mm ²	H05VVF		Indoor unit	52 / N / PE	
DHW pump	PW2	3 x 1,5mm ²	H05VVF			58 / N / PE	
Signal cable IDU - ODU	CAN-BUS	2 x 2 x 0,75mm ²	LIYCY (TP)	30m		Can High 31(H) Can Low 32(L) 12V not connected	2-wire connection, shielding in both ends
Power supply	IDU AWE/ AWM/AWMS	5 x 2,5mm ²	NY Y		Indoor unit		sub-distribution 3 x C16
Power supply	IDU AWB	3 x 1,5mm ²	NY Y		Indoor unit	L / N / PE	sub-distribution 1x C16
Heating cable		3 x 1,5mm ²	NY Y	3m	Indoor unit	56 / N / (HC / HC)	IDU / HC / HC
EMS - Module	MM100, MS100..	0,5mm ²	J-Y (ST)Y 2 x 2 x 0,6	100m	Indoor unit	19 / 20	
0-10V control boiler	EM0	2 x 2 x 0,75mm ²	LIYCY (TP)		Indoor unit (IDU AWB)	38 / 39	
PV-Function		0,4mm ²	J-Y (ST)Y 2 x 2 x 0,6		From inverter on terminal I1 or I4 in IDU, EVU-block or Smart Grid		
Smart Grid		0,4mm ²	J-Y (ST)Y 2 x 2 x 0,6		From load management controller on terminal I4, connection 49, 50 in IDU		
EVU-block		3 x 1,5mm ²	H05VVF		From load management controller on terminal I1, connection 13, 14 in IDU		

Table 11 Connections in indoor units IDU AWE/AWM/AWMS and AWB

Sensor	Designation	min. cross-section	type of cabel	max. length	connected at:	connection terminal:	Power source
Outdoor	T1	0,5 mm ²	J-Y (ST)Y 2 x 2 x 0,6		Indoor unit	3 / 4	
Flow	T0	0,5 mm ²	J-Y (ST)Y 2 x 2 x 0,6		Indoor unit	1 / 2	
Hot water (DHW)	TW1	0,5 mm ²	J-Y (ST)Y 2 x 2 x 0,6		Indoor unit	5 / 6	
Dew sensor	MK2 (max. 5x)	0,5 mm ²	cable integrated		Indoor unit	34 / 35	
Mixed heating circuit	TC1	0,5 mm ²	J-Y (ST)Y 2 x 2 x 0,6	100m	MM100	1 / 2	
Pool temperature	TC1	0,5 mm ²	J-Y (ST)Y 2 x 2 x 0,6	100m	MP100	1 / 2	

Table 12 Cable plan sensor

11.5 Measurements from temperature sensors

CAUTION:
Physical injury or material damage due to incorrect temperature

If sensors with incorrect characteristics are used, the temperatures may be too high or too low.

- ▶ Make sure that the temperature sensors used comply with the specified values (see tables below).

°C	Ω	°C	Ω	°C	Ω	°C	Ω
20	12488	40	5331	60	2490	80	1256
25	10001	45	4327	65	2084	85	1070
30	8060	50	3605	70	1753	90	915
35	6536	55	2989	75	1480	-	-

Table 13 Sensor T0, TCO, TC1

°C	Ω	°C	Ω	°C	Ω	°C	Ω
20	14772	40	6653	60	3243	80	1704
25	11981	45	5523	65	2744	85	1464
30	9786	50	4608	70	2332	90	1262
35	8047	55	3856	75	1990	-	-

Table 14 Sensor TW1

°C	Ω	°C	Ω	°C	Ω
-40	154300	5	11900	50	1696
-35	111700	10	9330	55	1405
-30	81700	15	7370	60	1170
-25	60400	20	5870	65	980
-20	45100	25	4700	70	824
-15	33950	30	3790	75	696
-10	25800	35	3070	80	590
-5	19770	40	2510	85	503
0	15280	45	2055	90	430

Table 15 Sensor T1

12 System Commissioning Report

Commissioning date:	
Customer address:	Last name, first name:
	Postal address:
	Town:
	Telephone:
Installation company:	Last name, first name:
	Street:
	Town:
	Telephone:
Product information:	Product type:
	TTNR:
	Serial number:
	FD-no.:
System components:	Receipt/value
Temperature controller	<input type="checkbox"/> Yes <input type="checkbox"/> No
Temperature controller with humidity sensor	<input type="checkbox"/> Yes <input type="checkbox"/> No
Type:	
Solar integration	<input type="checkbox"/> Yes <input type="checkbox"/> No
Buffer cylinder	<input type="checkbox"/> Yes <input type="checkbox"/> No
Type/Volume (l):	
Hot water cylinder	<input type="checkbox"/> Yes <input type="checkbox"/> No
Type/Volume (l):	
Other components	<input type="checkbox"/> Yes <input type="checkbox"/> No
Which?	
Minimum clearances heat pump:	
Is the heat pump standing on a solid, flat surface?	<input type="checkbox"/> Yes <input type="checkbox"/> No
Is the heat pump stably anchored?	<input type="checkbox"/> Yes <input type="checkbox"/> No
Is the heat pump standing in a location where snow cannot slide off the roof onto it?	<input type="checkbox"/> Yes <input type="checkbox"/> No
Minimum wall clearance?mm	
Minimum clearances at sides?mm	
Minimum distance to roof?mm	
Minimum distance in front of the heat pump?mm	
Condensate hose, heat pump	
Does the condensate hose have a heating cable?	<input type="checkbox"/> Yes <input type="checkbox"/> No
Connections at the heat pump	
Were the connections established correctly?	<input type="checkbox"/> Yes <input type="checkbox"/> No
Who installed/prepared the connecting pipework?	
Minimum clearances, indoor unit:	
Minimum wall clearance?mm	
Minimum distance in front of the unit?mm	
Heating:	
Pressure determined in the expansion vessel? bar	
The heating system has been filled according to the pressure determined in the expansion vessel to bar	
Has the heating system been flushed before installation?	<input type="checkbox"/> Yes <input type="checkbox"/> No
Has the particle filter been cleaned?	<input type="checkbox"/> Yes <input type="checkbox"/> No
Electric connection:	
Were the low voltage cables installed with a minimum distance of 100 mm from 230 V/400 V cables?	<input type="checkbox"/> Yes <input type="checkbox"/> No
Were the CAN-BUS connections established as specified in the instructions?	<input type="checkbox"/> Yes <input type="checkbox"/> No
Has a power guard been connected?	<input type="checkbox"/> Yes <input type="checkbox"/> No
Is the outside temperature sensor T1 on the coldest side of the house?	<input type="checkbox"/> Yes <input type="checkbox"/> No
Power supply:	
Is the phase sequence of L1, L2, L3, N and PE in the outdoor unit correct?	<input type="checkbox"/> Yes <input type="checkbox"/> No

Is the phase sequence of L1, L2, L3, N and PE in the indoor unit correct?	<input type="checkbox"/> Yes <input type="checkbox"/> No
Does the power supply correspond to the installation instructions?	<input type="checkbox"/> Yes <input type="checkbox"/> No
Fuse for heat pump and electric booster heater, tripping characteristics?	
Manual operation:	
Was a function check of individual component groups performed (pump, mixing valve, diverter valve, compressor, etc.)?	<input type="checkbox"/> Yes <input type="checkbox"/> No
Comments:	
Have the temperatures in the menu been checked and documented?	<input type="checkbox"/> Yes <input type="checkbox"/> No
T0	_____ °C
T1	_____ °C
TW1	_____ °C
TC0	_____ °C
TC1	_____ °C
Settings for auxiliary heater:	
Time delay, auxiliary heater	
Block auxiliary heater	<input type="checkbox"/> Yes <input type="checkbox"/> No
Electric booster heater connected load settings	
Auxiliary heater, maximum temperature	_____ °C
Safety functions:	
Block heat pump at low outside temperatures	
Has the commissioning been performed correctly?	<input type="checkbox"/> Yes <input type="checkbox"/> No
Does the installer have to perform additional measures?	<input type="checkbox"/> Yes <input type="checkbox"/> No
Comments:	
Installer signature:	
Customer's signature:	

Table 16 System Commissioning Report

Middle East and Caucasian Area

Bosch Termoteknik Isıtma ve Klima Ticaret A.S.
Aydınevler Mah. İnönü Cad. No:20
Küçükyalı Ofispark A Blok
34854 Küçükyalı / Maltepe - İSTANBUL
Tel: +90 216 432 08 00

Products manufactured by
Bosch Thermotechnik GmbH
Junkersstrasse 20-24
D-73249 Wernau
www.bosch-thermotechnology.com

Robert Bosch (Australia) Pty Ltd
Thermotechnology Division
1555 Centre Road
Clayton Victoria 3168

Australia
Phone: 1300 30 70 37
Fax: 1300 30 70 38
www.bosch-climate.com.au

New Zealand
Phone: 0800 54 33 52
Fax: 0800 54 33 55
www.bosch-climate.co.nz