

6 720 648 053-00.2T

Floor standing condensing boiler

Uni Condens 6000F

Output range 800 - 1200 kW



BOSCH

Installation instructions

1 Key to symbols and safety instructions

1.1 Explanation of symbols

Warnings

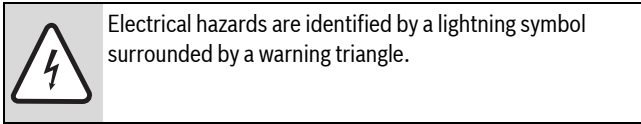
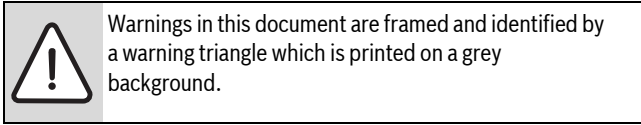

Keywords indicate the seriousness of the hazard in terms of the consequences of not following the safety instructions.

- **NOTICE** indicates that material damage may occur.
- **CAUTION** indicates that minor to medium injury may occur.
- **WARNING** indicates that serious injury may occur.
- **DANGER** indicates possible risk to life.

Important information

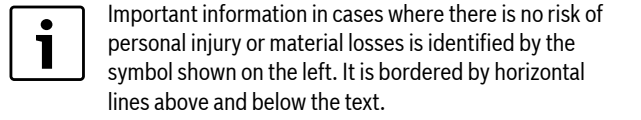

Additional symbols

Symbol	Meaning
▶	a step in an action sequence
→	a reference to a related part in the document or to other related documents
•	a list entry
–	a list entry (second level)

Table 1

1.2 Safety instructions

Danger through failure to consider your own safety in an emergency such as a fire

- ▶ Never put your life at risk. Your own safety is paramount.

If you smell gas

- ▶ close the gas tap.
- ▶ Open the windows.
- ▶ Never operate electrical switches, including telephones, plugs or doorbells.
- ▶ Extinguish all naked flames.
- ▶ No open fire.
- ▶ Never smoke.
- ▶ Never use lighters.
- ▶ Warn all occupants in the building, but do not ring doorbells.
- ▶ Leave the building and telephone your national gas emergency service on 0800 111999 **from an outside phone**.

If you smell flue gas

- ▶ Switch off the appliance.
- ▶ Open windows and doors.
- ▶ Notify an authorised contractor.

Electric shock hazard

- ▶ Before carrying out any work on the heating system, disconnect the heating system from the power supply across all poles. For example, press the emergency stop switch outside the boiler room. It is not enough to switch off at the boiler control unit.
- ▶ Safeguard the heating system against unintentional reconnection.
- ▶ Observe the country-specific rules and regulations when making the electrical connection, commissioning, servicing and carrying out maintenance.

Siting, conversion

An insufficient supply of air can result in dangerous escape of flue gas.

- ▶ Only have the boiler installed or modified by a competent person.
- ▶ Never modify any boiler components in contact with exhaust gas.
- ▶ With **open flue appliances**: Never cover or reduce the size of air vents in doors, windows or walls. If draught-proof windows are fitted, ensure there is an adequate ventilation.
- ▶ Ensure that the boiler installation room remains free from the risk of frost.
- ▶ The heating system must be installed and operated in accordance with the current: Statutory Instrument Laws, Gas Safety Regulations, IEE Regulations, Building Regulations, Local Water By-Laws, Health & Safety document 635 (The Electricity at Work Regulations) and any other local requirements. Observe all European and local installation standards, building regulations and the latest edition of the wiring regulations. Chemically aggressive substances, can corrode the appliance and invalidate any warranty.

Thermal disinfection

▶ Risk of scalding!

Monitor any operation with temperatures in excess of 60 °C.

Inspection and maintenance

- ▶ **Recommendation for customers:** Arrange a maintenance and service contract with an authorised contractor, covering an annual inspection and responsive maintenance.
- ▶ The user is responsible for the general and environmental safety of the heating system.
- ▶ Immediately correct all faults to prevent system damage!
- ▶ Use only genuine spare parts from the manufacturer. Losses caused by the use of spare parts and accessories not supplied by the manufacturer are excluded from the manufacturer's warranty.

Explosive and highly flammable material

- ▶ Never use or store highly flammable materials (paper, thinners, paints etc.) near the boiler.

Combustion/room air

- ▶ Keep the combustion/ambient air free of corrosive substances (e.g. halogenated hydrocarbons that contain chlorine or fluorine compounds). This will help prevent corrosion.
- ▶ Keep the combustion air supply free of dust.

Instructing the customer

- ▶ Instruct the customer about how the boiler works and is operated.
- ▶ Inform customers that they must not carry out any modifications or repairs.

Disposal

- ▶ Dispose of packaging in an environmentally responsible manner.

2 About the boiler

2.1 Type overview

Type	Output
Uni Condens 6000F	800 kW, 1000 kW, 1200 kW

Table 2 Type overview

2.2 Correct use

The Uni Condens 6000F condensing boiler has been designed for hot water heating systems in e.g. multiple dwelling units or for industrial purposes.

Any gas burner to EN 676 and EN 267 can be used if its operating range matches the boiler specification.

Only burners that have been tested and approved for electromagnetic compatibility (EMC) may be used.

CFB control units are used with these boilers.

For further details on correct use → chapter 2.6, page 4, chapter 2.7, page 5 and chapter 3, page 9.

2.3 Safety equipment

To ensure safe operation, the boilers must be equipped with the following safety equipment:

- The level of safety equipment must comply with at least EN 12828.
- Also observe country-specific regulations if these specify further requirements.
- Observe the maximum temperature high limit stat setting of 110 °C.

Equipment examples are included in the appendix, page 32. The components comprising the safety equipment are available as accessories.

2.4 CE Declaration of Conformity

The design and operation of this product conform to the applicable European directives and supplementary national requirements.

Conformity has been demonstrated. You can ask for a copy of the declaration of conformity. For this see the contact address at the back cover of these instructions.

2.5 Scope of supply

The boiler is supplied with its full casing. The boiler front cover is supplied separately and has to be fitted.

- ▶ On delivery, check that all packaging is in perfect condition.
- ▶ Check the delivery for completeness.

The standard delivery consists of:

- Boiler body with casing
- Front cover

2.5.1 Accessories supplied

The following accessories are included in the standard delivery and have to be fitted:

- Control unit retainer and cable conduit (delivered inside the combustion chamber)
- Sound insulation strip
- Siphon (delivered inside the combustion chamber)
- Insulating rings for blast tube (delivered inside the combustion chamber)
- Technical documentation

2.5.2 Required accessories

The following accessories are not part of the standard delivery but are required to operate the boiler:

- Burner
- Burner plate, drilled or undrilled
- Valve manifold
- Safety equipment
- Cleaning brushes
- Control unit

2.6 Operating conditions



During installation and operation of the heating system, observe all country-specific standards and guidelines. Also observe the details on the boiler rating plate. These are definitive and must be observed.



Set the burner to the combustion heating output QN specified on the data plate as a maximum.

Conditions of use	Unit	Value
Maximum permissible temperature, high-limit safety cut-out	°C	110
Maximum operating pressure	bar	6
Maximum number of burner starts	per annum	15 000

Table 3 Conditions of use

Operating conditions	Uni Condens 6000F	Uni Condens 6000F
Boiler water flow rate		
Min. boiler water temperature		
Operating interruption (total boiler shutdown)	None –	None –
Heating system control with mixing valve	in conjunction with a CFB control unit for	in conjunction with a CFB control unit 930 for
Minimum return water temperature	modulating operation.	constant boiler water temperatures or when supplemented by a third party control unit.
Miscellaneous	1)2)	1)

Table 4 Operating conditions

1) Maximum 15,000 burner starts per year In order not to exceed the number of burner starts, observe the information on setting the control unit and burner in the technical guide or installation instructions. If this value is still exceeded, please contact the manufacturer's customer service.

2) In order not to exceed the maximum number of burner starts per annum, the manufacturer offers full commissioning for CFB control units with function modules, burner and boiler as an alternative to 1). Any faults that may be present on site (e.g. incorrect sizing or setting of system components) must be corrected by the system installer.

2.7 Suitable fuels



The combustion of biogas is not permitted.

Permissible fuels

- Natural gas from the public gas supply in accordance with national regulations with a total sulphur content $< 50 \text{ mg/m}^3$.
- LPG in accordance with national regulations with a content of elementary sulphur $< 1.5 \text{ ppm}$ and volatile sulphur $< 50 \text{ ppm}$.

The boiler must only be operated with the specified fuels. Only burners that are suitable for the specified fuels may be used.

Observe the manufacturer's burner selection list and the burner manufacturer's instructions.

2.8 Data plate



If you contact the manufacturer with any questions about this product, always provide the details on the data plate. These details enable us to assist you specifically and quickly.

The data plate is fitted to the back of the boiler casing.

There you will find information such as the serial number, output and approval details.

2.9 Tools, materials and auxiliary equipment

For the installation and maintenance of the boiler, standard tools are required, as used for heating, gas, water and electrical installations.

2.10 Product description

The Uni Condens 6000F is a floor standing condensing boiler with a slim, compact design and a small footprint thanks to the combustion chamber being located at the top and the condensation heating surface being located at the bottom. In the following, it is referred to as the Uni Condens 6000F or the boiler.

The Uni Condens 6000F has two thermohydraulically separated return connections for the high and low temperature circuits.

For the type-tested boiler sizes with internal condensing heat exchanger and CE designation, the components that come into contact with hot gas and condensate are made of stainless steel.

Equip the Uni Condens 6000F with a suitable burner.

Optional accessories can be found in the general catalogue.



NOTICE: System damage through the use of an incorrect burner.

- ▶ Only use burners that meet the technical requirements of the boiler (→ chapter 2.11, page 7).

The following are the main components of the Uni Condens 6000F are (→ Fig. 1, page 6):

- Boiler body [1] in conjunction with a burner
The boiler block transfers the heat produced by the burner to the heating water.
- Thermally insulating casing
The boiler jacket and thermal insulation reduce energy losses.
- Control unit [8] (accessory)
The control unit monitors and controls all electrical boiler components.

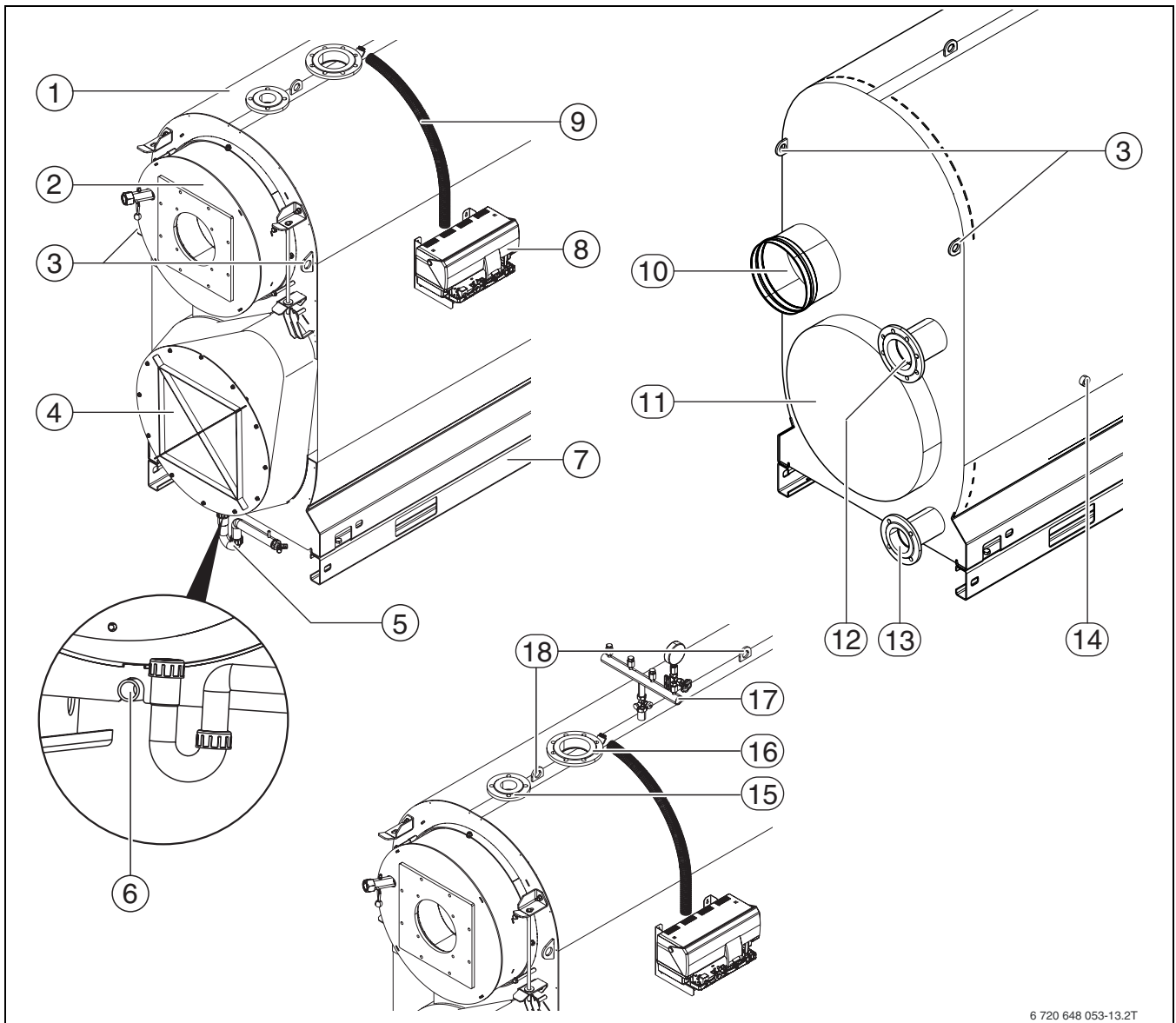

6 720 648 053-13.2T

Fig. 1 Boiler overview

- [1] Boiler body
- [2] Combustion chamber door
- [3] Locking lug to secure the load during transportation
(not for lifting the boiler)
- [4] Flue gas collector
- [5] Condensate drain, siphon
- [6] Drain
- [7] Base frame rail
- [8] Control unit (accessory)
- [9] Cable conduit
- [10] Flue gas connection
- [11] Inspection opening, reversing chamber
- [12] Return 1 (RK1), low temperature return
(main return)
- [13] Return 2 (RK 2), high temperature return
- [14] Inspection opening on the water side (both sides)
- [15] Flow safety connection
- [16] Boiler flow
- [17] Valve manifold (accessory)
- [18] Lifting point

2.1.1 Dimensions and specification

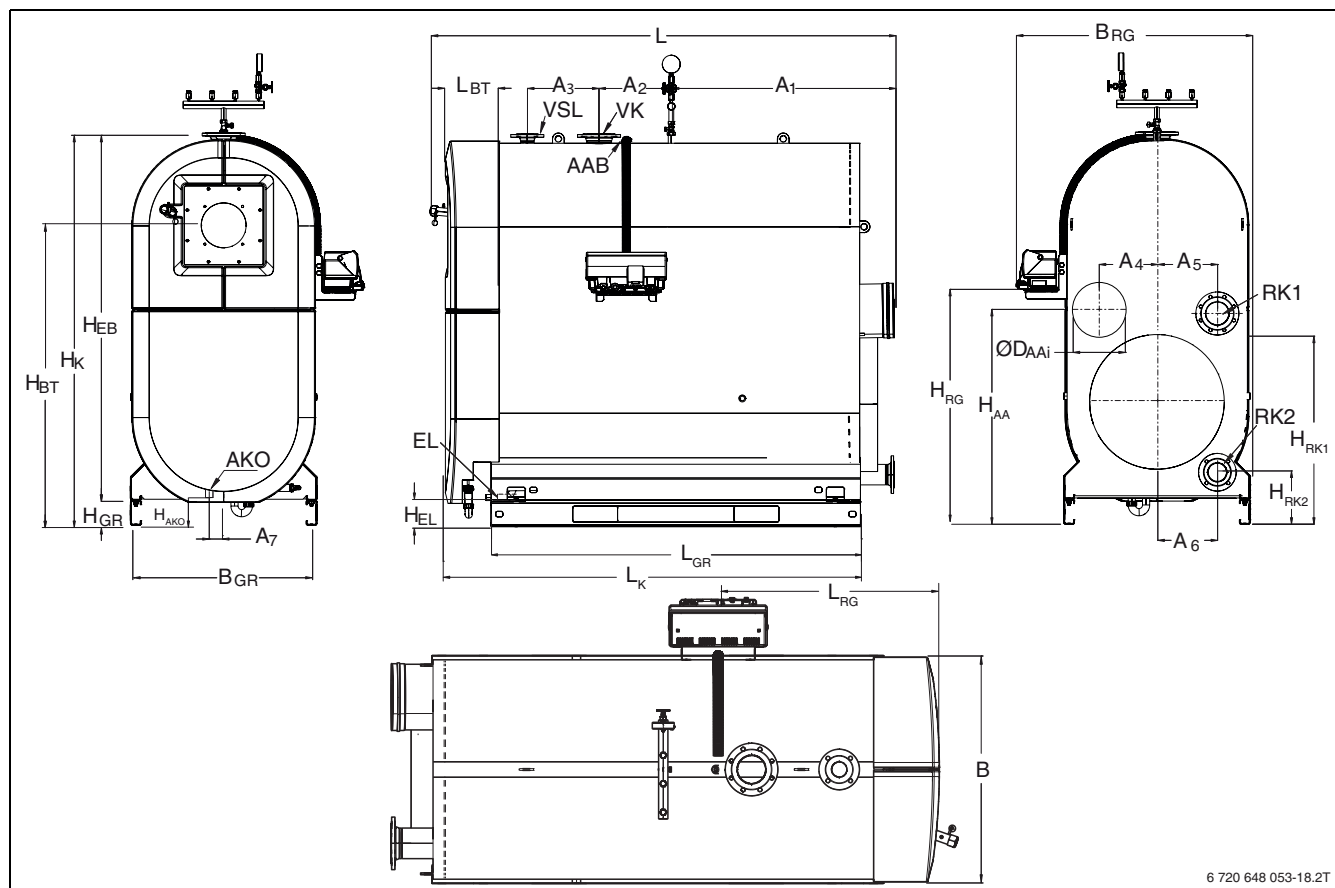

Fig. 2 Boiler dimensions 800 kW, 1000 kW, 1200 kW

2.1.1.1 Dimensions

	Abbreviation	Unit	Boiler type		
			800	1000	1200
Boiler size	-	kW	800	1000	1200
Length	L	mm	2545	2580	2580
	L _K	mm	2360	2395	2395
Length incl. burner	L _{BR}	mm	Subject to burner		
Width	B	mm	960	1040	1040
Width incl. control unit	B _{RG}	mm	1220	1330	1330
Height	H _K	mm	2014	2192	2192
Height of base frame ¹⁾	H _{GR}	mm	140		
Installation clearance control unit, cable conduit	L _{RG}	mm	906	906	906
Installation height, control unit	H _{RG}	mm	1300	1300	1300
Transport length ²⁾	∠	mm	2405	2455	2455
Transport width	B	mm	960	1040	1040
Transport height ¹⁾	H _{EB}	mm	1874	2052	2052
Installation area base frame	L _{GR}	mm	2060		
	B _{GR}	mm	960	1040	1040
Flue outlet	Ø D _{AAinternal}	mm	253	303	303
	H _{AA}	mm	1064	1193	1193
	A ₄	mm	299	348	348
Combustion chamber	Length	mm	1904	1954	1954
	Ø _{interior}	mm	630	688	688
Combustion chamber door	L _{BT}	mm	227		
	H _{BT}	mm	1508	1653	1653
Blast tube	Minimum depth	mm	210		

Table 5 Boiler dimensions

	Abbreviation	Unit	Boiler type		
			800	1000	1200
Boiler flow ³⁾	Ø VK _{PN6}	DN	100	125	125
	A ₂	mm	403	405	405
Boiler return flow ¹³⁾	Ø RK1 _{PN6}	DN	100	125	125
	H _{RK1}	mm	1007	1148	1148
	A ₅	mm	320	380	380
Boiler return flow ³⁾	Ø RK2 _{PN6}	DN	80	100	100
	H _{RK2}	mm	300	263	263
	A ₆	mm	320	390	390
Safety line flow ³⁾	Ø VSL _{PN16}	DN		65	
	A ₃	mm		400	
Fittings manifold connection	Ø AAB	"		G1	
	A ₁	mm	1200	1245	1245
Condensation outlet	Ø AKO	DN	40	40	40
	H _{AKO}	mm	180	180	180
	A ₇	mm	71	70	70
Drain	Ø EL	"		R1	
	H _{EL}	mm	161	164	164

Table 5 Boiler dimensions

- 1) The base frame rails can be temporarily removed to reduce the transport height.
 2) after the dismantling of the combustion chamber door
 3) Flange to EN 1092-1

2.11.2 Technical Data

	Unit	Boiler type			
		800	1000	1200	
Maximum flow temperature ¹⁾	°C		110		
Permissible operating pressure	bar		6		
CE designation, product ID			applied for		
Weight (empty)	net	kg	1510	1760	1790
Operating weight ²⁾	gross	kg	2440	2960	2980
Water content		l	930	1200	1190
Hot gas volume		l	1020	1310	1320
Combustion heat output	Full load, max.	kW	742	928	1114
[Burner output QN (Hi)]	Partial load 30 %	kW	223	278	334
Available draught		Pa	Subject to burner specification (50) ³⁾		
Pressure drop on the hot gas side		mbar	6.4	6.5	7.5

Table 6 Technical Data

- 1) Safety limit (high limit safety cut-out). Maximum possible flow temperature = safety limit (high limit safety cut-out) – 18 K.
 Example: Safety limit (high limit safety cut-out) = 100 °C, maximum possible flow temperature = 100 – 18 = 82 °C
 2) Details excl. burner
 3) Value in brackets is the recommended draught.

2.11.3 Values for calculating the flue gas

Values at system temperature 50/30 °C

		Unit	Boiler type		
			800	1000	1200
Rated output, natural gas	Full load	kW	800	1000	1200
	Partial load 30 %	kW	243	303	364
CO ₂ content	Natural gas	%		10	
Flue gas temperature ¹⁾	Full load	°C		40	
	Partial load 30 %	°C		30	
Flue gas mass flow	Full load	kg/s	0.300	0.375	0.451
	Partial load 30 %	kg/s	0.089	0.112	0.134

Table 7 System temperature 50/30 °C

1) Calculated flue gas temperature for cross-sectional calculation to EN 13384 (average value across the series). The actual flue gas temperature may differ from this, subject to burner setting and actual system temperature.

Values at system temperature 80/60 °C

		Unit	Boiler type		
			800	1000	1200
Rated output, natural gas	Full load	kW	725	906	1090
	Partial load 30 %	kW			
CO ₂ content	Natural gas	%		10	
Flue gas temperature ¹⁾	Full load	°C	66	66	66
	Partial load 30 %	°C		36	
Flue gas mass flow	Full load	kg/s	0.316	0.395	0.475
	Partial load 30 %	kg/s	0.095	0.118	0.142

Table 8 System temperature 80/60 °C

1) Calculated flue gas temperature for cross-sectional calculation to EN 13384 (average value across the series). The actual flue gas temperature may differ from this, subject to burner setting and actual system temperature.

3 Information on installation and operation



Regarding installation and operation of your heating system, observe all relevant national standards and guidelines. The information on the data plate is binding and must be observed.

3.1 Standards, regulations and directives

Observe all technical guidelines, country-specific regulations and standards applicable to installation and operation. These include the following:

- Local building regulations concerning the installation conditions.
- Local building regulations concerning the ventilation facilities and chimney connection.
- Requirements for the electrical connection to the power supply.
- Technical rules of the gas supplier concerning the connection of the gas burner to the public gas mains
- Regulations and standards concerning the safety equipment level of wet heating systems.

The level of safety equipment must be at least compliant with EN 12828. Also observe country-specific regulations if these specify further requirements.

3.2 Duty to obtain a permit and provide notification

- The local gas supply utility might need to be notified of and approve the gas boiler installation
- Please note that regional approvals may be required for the flue system and condensate connection to the public sewage system
- Prior to commencing installation, inform the relevant bodies and the water board.

3.3 Burner selection and settings

The sizing and settings of the burner have a significant influence on the service life of the heating system. Every load cycle (burner on/off) causes thermal stress (loads on the boiler body). **The number of burner starts must therefore not exceed 15,000 per year.**

The following recommendations and settings are designed to meet this criterion (**see also information on setting the control unit and the hydraulic connection to the heating system**). If you still cannot meet this criterion, please contact the Bosch sales or service department.



The number of burner starts can be checked in the MEC (→ chapter 3.8, page 10).

- Set the burner output as low as possible. **Set the burner to the combustion heating output QN specified on the data plate as a maximum.** Never overload the boiler.

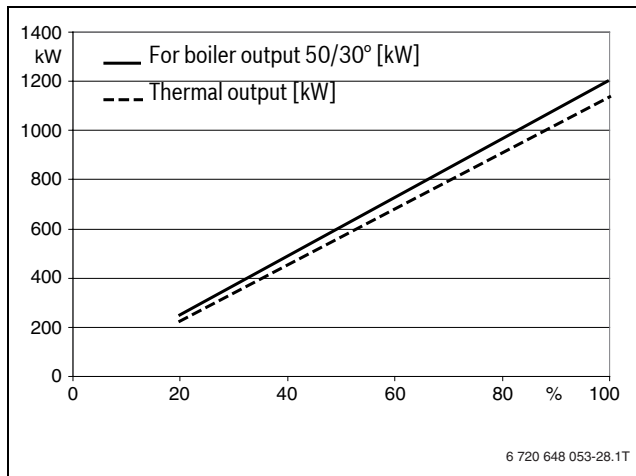

Fig. 3 Graph

- Take fluctuating net calorific values of the gas into account; check the maximum value with the gas supply utility.
- Only use burners that are suitable for the specified fuels. Observe the burner manufacturer's instructions.
- Burners must only be adjusted by a competent person.

3.4 Installation requirements

The installation room must meet the following conditions:

- In the boiler installation room, an ambient temperature of between 0 °C and 35 °C must be ensured (refer to the requirements of BS 6644).
- The installation room must be equipped with the required air vents.
- An adequate supply of fresh air must be ensured.

The ventilation to the plant room must meet the minimum requirements stated in the building regulations. Please consider the additional free ventilation for open flue appliances.



Take into account additional consumers of ventilation air (e.g. compressors) when sizing.

For boiler room ventilation sizes please refer to BS 6644 and IGE/UP/10.

Regarding the size of the combustion air vent, it is essential that the system installer seeks the agreement of the responsible approval or building regulations body.

- ▶ Never install system components that could be damaged by frost near the combustion air vents. If necessary, install a device to preheat the ventilation air (e.g. a heater battery in the combustion air vent).
- ▶ Never position objects in front of these vents. Keep the combustion air vents free at all times.
- ▶ Never store flammable materials or liquids in the immediate vicinity of the heat source.

3.5 Combustion air quality

- ▶ Keep the supply of combustion air free of corrosive substances (e.g. halogenated hydrocarbons that contain chlorine or fluorine compounds). This will help prevent corrosion.
- ▶ Never use or store chlorinated cleaning agents or halogenated hydrocarbons (as contained in spray cans, solvents or cleaning agents, paints and adhesives, for example) in the boiler room.
- ▶ Keep the combustion air supply free of dust.
- ▶ If building work is taking place in the installation room and creating a lot of dust, shut the boiler down. A burner contaminated during building work must be cleaned before commissioning.

3.6 Heating water quality

The quality of the fill and top-up water is an essential factor for increased efficiency, functional reliability, long service life and for maintaining the constant operational condition of a heating system. If the system is filled with water that has a high calcium hardness, this will be deposited on the heat exchanger surfaces and will obstruct the transfer of heat to the heating water. As a result, the wall temperatures of the stainless steel heat exchanger surfaces will increase and the thermal stress (loads on the boiler body) will increase.

This is why the quality of the fill or top-up water must meet the conditions stipulated in the operator's log provided and be recorded in this log. The conditions for boilers > 600 kW require general water treatment independent of the water hardness and the volume of fill and top-up water.

3.7 Using of antifreeze



Chemical additives that are not certified as safe for use by the manufacturer must not be used.

Antifreeze based on glycol has been used in heating systems for many years, for example Antifrogen N manufactured by Clariant.

The use of other types of antifreeze should not be a cause for concern if the product is comparable with Antifrogen N.

Observe the antifreeze manufacturer's instructions. Follow the manufacturer's details regarding mixing ratios.

The specific thermal capacity of Antifrogen N antifreeze is lower than the specific thermal capacity of water. To enable the transfer of the required heat output, increase the required flow rate accordingly. This should be taken into account when sizing the system components (e.g. pumps) and the pipework.

As the heat transfer medium has a higher viscosity and density than water, take the higher pressure drop through the pipework and other system components into account.

Check the resistance of all plastic or non-metallic components in the system separately.

3.8 Control unit settings



The boiler needs to be operated with a Bosch CFB control unit.

The purpose of optimum control unit settings is to achieve long burner run times and avoid rapid temperature changes in the boiler. Gentle temperature changes result in a longer service life of the heating system. The control strategy of the control unit must therefore be prevented from becoming ineffective, i.e. through the boiler water regulator switching the burner on and off.

- ▶ Maintain the minimum differential between the selected shutdown temperature of the high limit safety cut-out, the temperature regulator, the maximum boiler water temperature and the maximum temperature demand (→ table 9).



The maximum boiler water temperature can be selected on the control unit (MEC) in the "Boiler parameters" menu, under menu item "Max. shutdown temperature".

- ▶ Select set temperatures for the heating circuits that are as low as possible.
- ▶ Start heating circuits (e.g. when starting up in the mornings) at 5-minute intervals.



If the Bosch CFB control unit is used, burner modulation in standard mode is not enabled for 3 minutes. Never modulate upwards more quickly than this.

Adjustable parameter (max. temperature)	CFB 910	CFB 840	
High limit safety cut-out (STB) ¹⁾	110 °C	110 °C	
	↓↑ minimum 5 K ↓↑		
Temperature regulator (TR) ¹⁾	105 °C	90 °C	↑
	↓↑ minimum 6 K ↓↑		↓
Max. boiler water temperature	99 °C	84 °C	
	↓↑ minimum 7 K ↓↑		
Max. temperature demand ²⁾ of HC ³⁾ and DHW ⁴⁾	92 °C	77 °C	

Table 9 Adjustable parameters CFB 910 and CFB 840

- 1) Set the high limit safety cut-out and temperature controller as high as possible, but ensure the settings are at least 5 K apart.
- 2) Both temperature demands must always be at least 7 K below the maximum boiler water temperature.
- 3) The temperature demand of heating circuits fitted with a mixing valve is composed of the set flow temperature and parameter "Boiler rise" in the heating circuit data menu.
- 4) The temperature demand of DHW heating is composed of the set DHW temperature and parameter "Boiler rise" in the DHW menu.

Settings for boiler water regulator and maximum boiler water temperature

The boiler water regulator is only designed to allow emergency operation with an adjustable boiler water temperature if the control electronics

fail. In standard control mode, the function of the boiler water regulator is provided by the maximum boiler water temperature. The maximum boiler water temperature can be selected in the control unit in the "Boiler parameters" menu, under menu item "Max. shutdown temperature".

Control unit settings

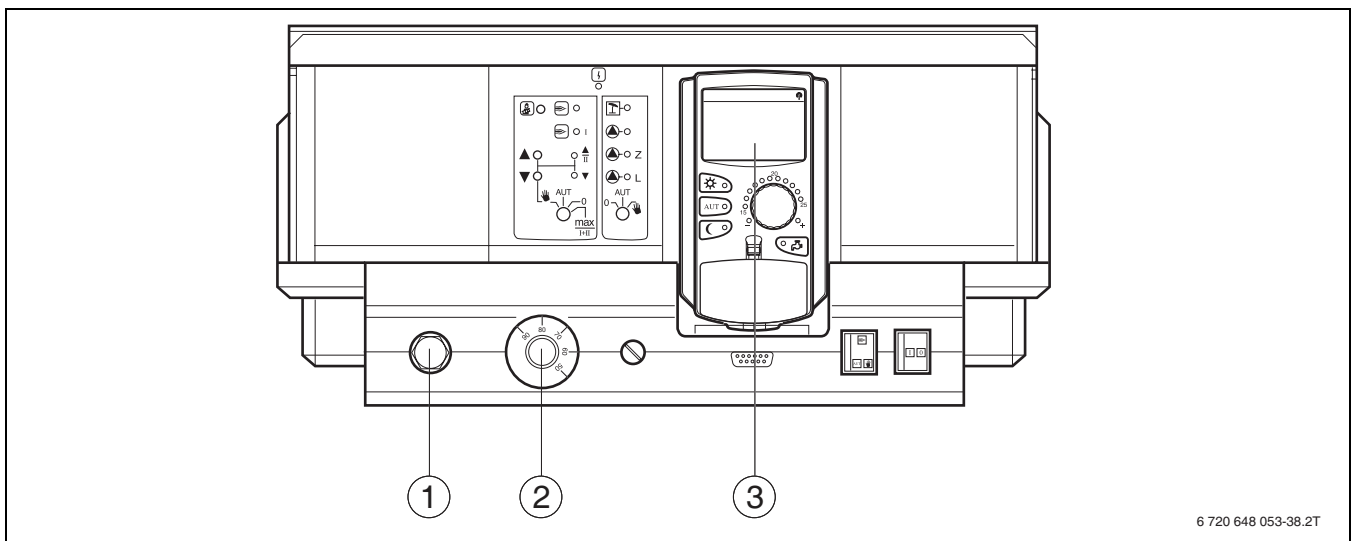

Fig. 4 Control unit settings

- [1] High limit safety cut-out
- [2] Temperature regulator
- [3] MEC

- ▶ Select temperatures (→ table 9, page 11) at high limit safety cut-out [1] in the control unit and at temperature controller [2].
- ▶ Select the maximum boiler water temperature at the MEC [3].



The maximum temperature demand is not a value that is directly selected. The maximum temperature demand is composed of the set temperature and the rise.

Example DHW demand (where the 4000 series controls the DHW system):

Sum of the set DHW temperature (60 °C) and parameter "Boiler rise" (20 °C) in the "DHW" menu:
 60 °C + 20 °C = Maximum temperature demand 80 °C

Example heating circuits (where the 4000 series controls the heating circuits):

Add of the set temperature of the heating circuit with mixing valve with the highest temperature required (70 °C) and parameter "Boiler rise" (5 °C) in the "Heating circuit data" menu:
 70 °C + 5 °C = Maximum temperature demand 75 °C



All maximum temperature demands must always be 7 K below the maximum selected boiler water temperature.

Notes on setting third party control units



NOTICE: System damage due to incorrect sensor position!

The sensors of the safety cut-out (STB) and of the thermostat (TR) **must** be fitted at the installation site (→ picture 23, [1], page 22) on the top of the boiler.

- ▶ In the case of third party control units, match the sensor immersion sleeve to the diameter of the sensors used.
- ▶ Do not change the length of the immersion sleeve.



Observe the operating conditions in chapter 2.6, page 4.

Observe chapter 5.9, page 23 when installing sensors.

- The third party control unit (building management system or PLC controllers) must ensure a maximum internal boiler water temperature that is sufficiently different from the high limit safety cut-out. It must also be ensured that the digital burner controller rather than the boiler water temperature regulator switch the burner on and off.
- The control unit must ensure that the burner is switched to low load before being shut down. If this is not observed, the safety shut-off valve (SAV) in the gas train may lock out.
- Select control equipment that allows a gentle start-up with a time delay when the system is cold.
- After the burner demand, an automatic timer (for example) should limit the burner to low load for a period of approx. 180 seconds. This restricted heat demand will prevent uncontrolled starting and stopping of the burner.
- It must be possible to show the number of burner starts on the control unit used.

	Unit	Value
Temperature control unit	s	40
Monitor/limiter	s	40
Minimum difference between burner on and off temperatures	K	7

Table 10 Conditions of use

3.9 Hydraulic connection to the heating system

- ▶ If the system temperatures are different, use both return connectors RK1 (top) and RK2 (bottom).
- ▶ Connect heating circuits with high return temperatures to connector RK2, and heating circuits with low return temperatures to connector RK1.



For an optimum energy yield, we recommend supplying a flow rate of > 10 % of the total nominal flow rate via connector RK1, with a return temperature below the dew point.



If there are no varying return temperatures, only return connector RK1 needs to be connected.

- ▶ Restrict the water flow rate in the boiler to a temperature difference of at least 7 K between flow and return.



Restriction of the temperature difference is not necessary if the system is equipped with a dirt trap device.

- ▶ Size the pumps correctly.



High flow rates and oversized pumps can result in the accumulation of sludge or deposits on the heat exchanger surfaces.

- ▶ Before connecting the boiler, flush sludge and dirt out of the heating system.
- ▶ Ensure that no oxygen enters the heating water during operation.
- ▶ Only operate the boiler in sealed unvented systems.

If the boiler is nonetheless used in an open vented heating system, additional measures are required to protect against corrosion and prevent sludge entering the boiler. The technical safety devices also require to be matched (equipment and settings).

- ▶ Consult the Bosch sales or service department.

Information on boiler cascades:

- ▶ Select the boiler circuit pumps (flow rate) in accordance with the set boiler output.
- ▶ In the case of parallel switching of the boilers, maintain the same temperature difference across all boilers.

3.10 Setting the minimum and maximum pressure limiters

Maximum pressure limiter

The maximum pressure limiter (not part of the standard delivery) must be set in such a way that the safety valve is prevented from discharging. To achieve this, a safety differential of 0.5 bar must be maintained to the release pressure of the safety valve.

The maximum release pressure of the safety valve for the Uni Condens 6000F is 6 bar.

Example:

Safety valve pressure: $P_{SV} = 5 \text{ bar}$

Setting value, maximum pressure limiter:

$5 \text{ bar} - 0.5 \text{ bar} = 4.5 \text{ bar}$



The setting for the maximum pressure limiter can be found in the documentation provided with the pressure limiter.

Minimum pressure limiter

The minimum pressure limiter (not part of the standard delivery) must be set in such a way that no steam bubbles form in the boiler, and that the boiler operates safely.

This setting depends on the system conditions and the siting situation of the boiler system. For the setting value, the boiling pressure associated with the setting value of the high limit safety cut-out is relevant (high limit safety cut-out 110 °C equals 0.5 bar), as is the consumer at the highest geodetic level above the boiler.

Example:

Boiler system with high limit safety cut-out setting = 110 °C

Highest consumer above the boiler = 12 m
(10 m equates to approx. 1 bar) → 1.2 bar

Safety differential = 0.2 bar (fixed value)

Response pressure $P_{min} = 0.5 \text{ bar} + 1.2 \text{ bar} + 0.2 \text{ bar} = 1.9 \text{ bar}$



The setting for the minimum pressure limiter can be found in the documentation provided with the pressure limiter.

3.11 Pressure maintenance

- ▶ Size the expansion vessels correctly.
- ▶ Set the pre-charge pressures correctly.

If using pump-controlled pressurisation units, pressure fluctuations will occur. They can occur very frequently depending on the design of the system and the appliance settings. Even if these pressure fluctuations are small, if they occur very frequently they may cause considerable damage to the boiler, as it is designed for a predominantly static pressure load.

To protection against damage:

- ▶ Ensure that every heat source is equipped with a separate expansion vessel.
- ▶ Set the pre-charge pressure of the expansion vessel correctly.

Recommended minimum volume of the expansion vessels if using pump-controlled pressurisation units:

Floor standing condensing boiler	Capacity of expansion vessel in litres
Uni Condens 6000F-800	120
Uni Condens 6000F-1000	140
Uni Condens 6000F-1200	180

Table 11 Volume of expansion vessels

4 Transport



DANGER: Risk to life from inadequately secured boiler.

- ▶ Use suitable means to transport the boiler (e.g. several pallet trucks, a forklift truck, crane or heavy duty rollers).
- ▶ When transporting, secure the boiler to prevent it falling.



The transport height can be reduced by removing the base frame rails (→ Fig. 1, [7], page 6).

Securing the load

To secure the load during transportation:

- ▶ **Never** pull retaining straps (fixing straps, chains) [2] over the boiler insulation [1].
- ▶ **Only secure retaining straps to the locking lugs [3].**



The maximum tensile strength of each chain is 2 kN.

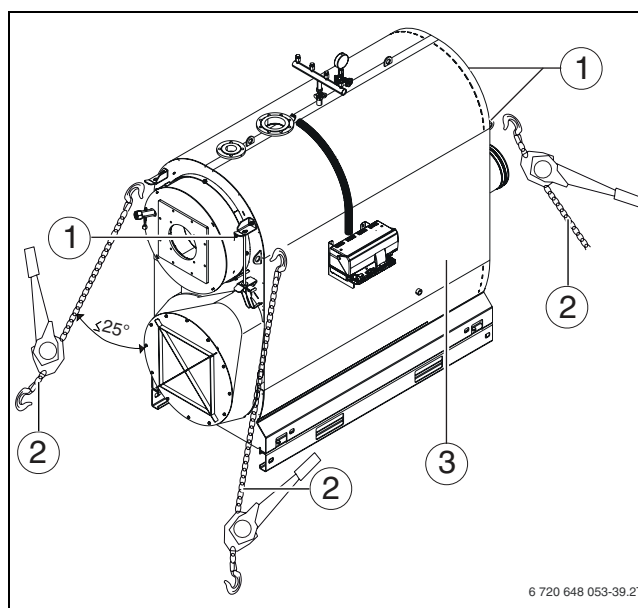

Fig. 5 Securing the load

- [1] Locking lugs
- [2] Retaining straps (fixing straps, chains)
- [3] Boiler insulation

4.1 Moving the boiler with a forklift truck, pallet truck or heavy duty rollers



DANGER: Risk to life through falling load.

- ▶ Distribute the boiler weight evenly across the forklift truck/pallet truck when lifting and moving the boiler.
- ▶ Observe the weight of the boiler and that of the means of transport.
- ▶ When transporting, secure the boiler to prevent it falling.



NOTICE: System damage through damaged boiler body. Only move the boiler with a forklift truck if the forks are long enough to reach right under the boiler.

- ▶ Prior to lifting the boiler, check that both lateral profiles of the boiler are supported by the forks of the forklift truck.
- ▶ Only lift the boiler at its profiles and base frame, not at the boiler body.
- ▶ Transport the boiler with the forks of the forklift truck inserted from the side.

The boiler can be transported by crane, forklift truck, several pallet trucks or rollers.

4.1.1 Lifting the boiler with a crane



DANGER: Risk to life through falling load.

- ▶ Only use lifting ropes of the same length.
- ▶ Only use lifting ropes that are in perfect condition.
- ▶ Only hook lifting tackle into the lifting eyes provided in the gusset plates on top of the boiler.
- ▶ **Never hook lifting tackle into the locking lugs on the front and back of the boiler, or into the connectors.**
- ▶ Only lift the boiler with a crane if you are suitably qualified to operate the crane.
- ▶ Never lift the boiler with a crane on its side or on end.

- ▶ Insert the hooks of the lifting tackle into the eyes in both gusset plates (→ Fig. 6, [2] of the boiler body.
- ▶ Attach the crane hook to the lifting tackle (→ Fig. 6, [1]).

i Never use the locking lugs [3] for lifting.

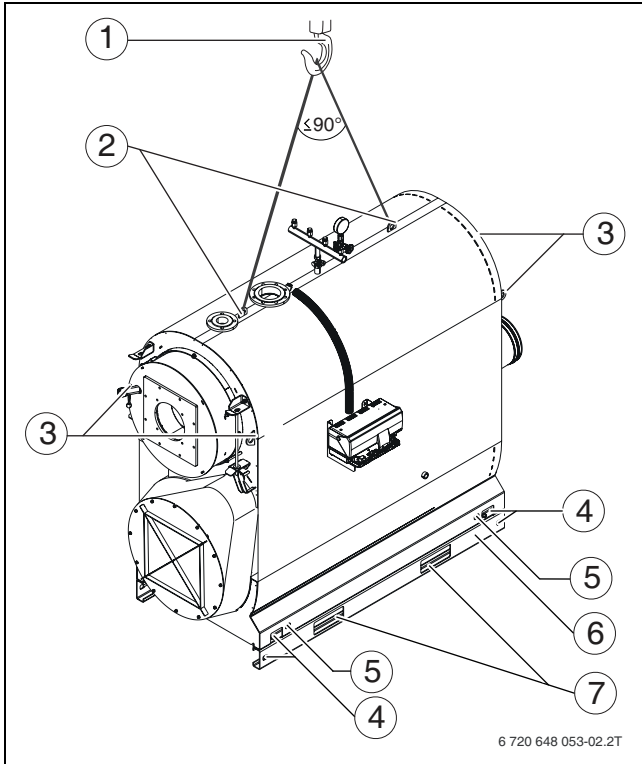

Fig. 6 Lifting the boiler with a crane

- [1] Crane hook
- [2] Lifting eyes
- [3] Locking lugs (not suitable for lifting by crane)
- [4] Towing points for tow ropes
- [5] Contact points for lifting with a car jack
- [6] Base frame rail
- [7] Contact points for lifting with a forklift truck

4.1.2 Moving the boiler with a forklift truck

- ▶ Pass the forks of the forklift truck through both profiles of the base frame.
- ▶ Observe the dimensions of the transport apertures.

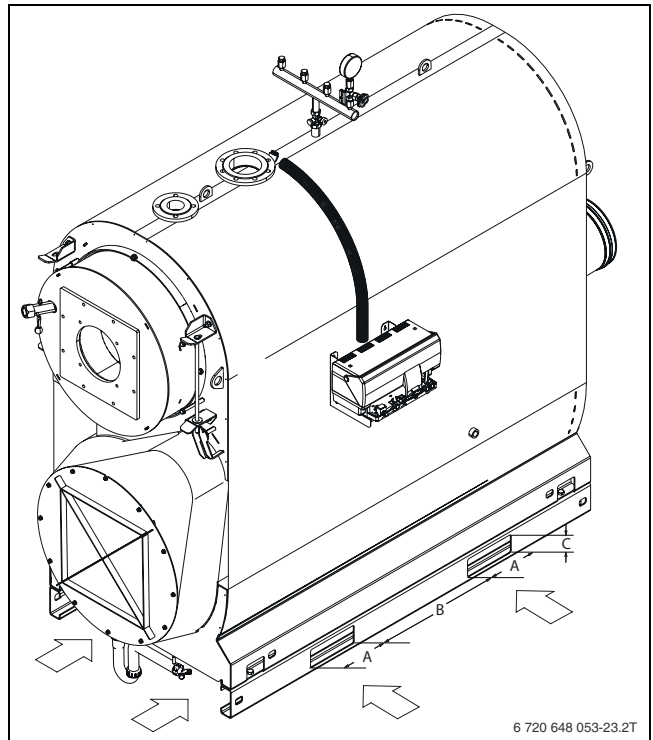

Fig. 7 Moving the boiler with a forklift truck

	Abbreviation	Dimensions in mm
Width	A	200
Spacing	B	700
Height	C	90

Table 12 Dimensions of the transport apertures

4.1.3 Moving the boiler with heavy duty rollers

- ▶ Position a heavy duty roller at each corner.

4.1.4 Moving the boiler with pallet trucks

- ▶ Push several pallet trucks under the base frame.
- ▶ Lift the boiler evenly with the pallet trucks.

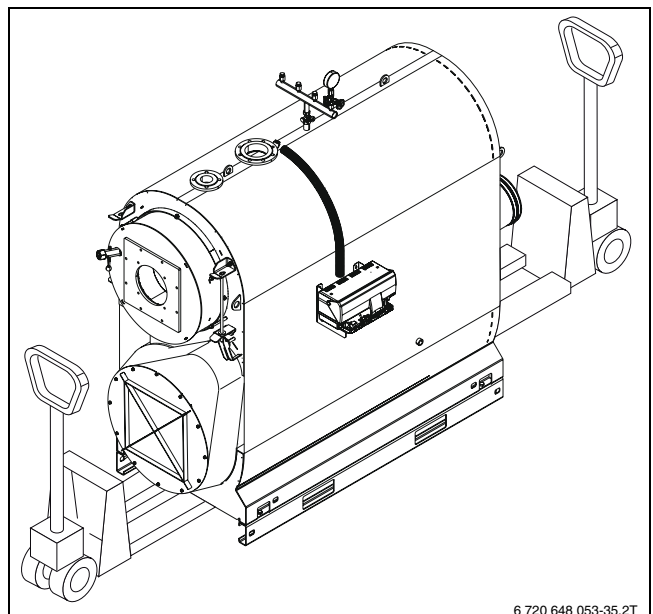

Fig. 8 Moving the boiler with two pallet trucks

i Note the position of the drain connector (→ Fig. 1, [6], page 6) and condensate drain (→ Fig. 1, [5], page 6).

5 Installation



For the installation and operation of the heating system, observe all country-specific standards and guidelines. The information on the data plate is binding and must be observed.

5.1 Siting the boiler



DANGER: Risk to life through poisoning. Insufficient ventilation can lead to dangerous flue gas leaks.

- ▶ Never close off or reduce the size of ventilation and extract air vents.
- ▶ Never operate the boiler unless faults are rectified.
- ▶ Inform the operator in writing of any faults and their associated risks.



DANGER: Risk of fire through flammable materials or liquids.

- ▶ Never store flammable materials or liquids in the immediate vicinity of the heat source.



NOTICE: System damage through frost!

- ▶ Site the boiler in a room free from the risk of frost.



Observe local regulations.

Installation room requirements:

- The support surface must provide sufficient load-bearing capacity and solidity.
- The installation room must be dry and free from the risk of frost.
- The size of the installation room must be adequate to ensure correct operation.

Minimum wall clearances

Observe the specified minimum wall clearances for the foundations or installation surface (→ table 13, page 15 and Fig. 9, page 15). The surface on which the boiler is to be positioned must be of load-bearing capacity, even and level. The front edge of the boiler should be flush with the edge of the plinth.

The combustion chamber door can be fitted to open from right to left or vice-versa (→ chapter 5.5 from page 18).

For details on the boiler length L and boiler width B → chapter 2.11, page 7.



Allow extra space if a flue silencer is to be installed.



If separation between the installation site and the boiler is required to prevent the transfer of structure-borne noise, apply anti-vibration measures (e.g. anti-vibration supports) before installing the boiler.

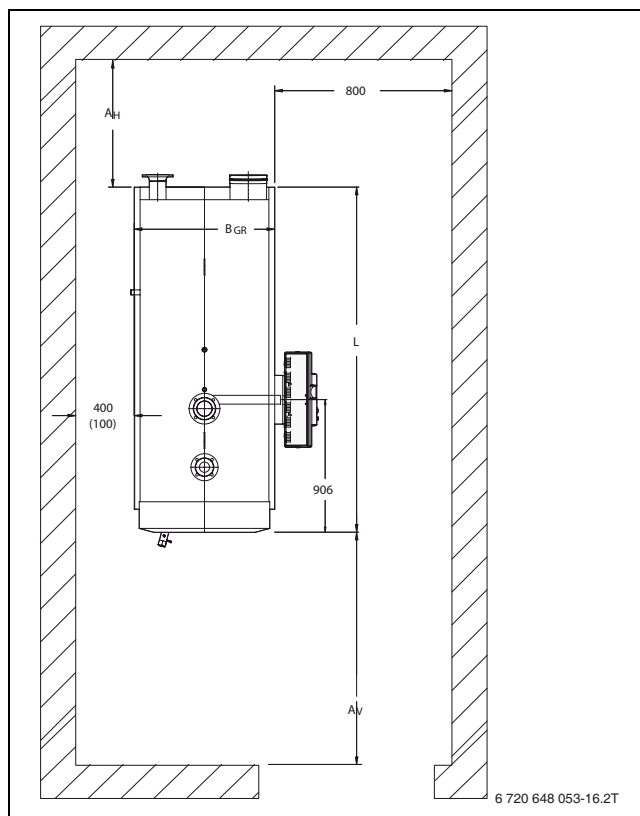

Fig. 9 Installation room with boiler (door opens to the right)

Boiler size	800 kW	1000 kW	1200 kW
A _H in mm ¹⁾		1000 (800)	
A _V in mm ²⁾³⁾	1800 (900)		1800 (1100)
A _S in mm		400 (50)	
L _{BR} in mm		Burner length + 200 (800)	
L _{RG} in mm			
Installation clearance control unit		906	
Cable conduit			
Length (L) foundations		2300	
Width (B) foundations	1060		1140

Table 13 Specified wall clearances (dimensions in brackets are minimum clearances)

- 1) If using a flue gas silencer, take its installed dimensions into account.
- 2) Factor in dimension L_{BR} (burner length) subject to burner overhang
- 3) This dimension depends on the burner length.

5.2 Fitting sound insulation strips



DANGER: Injury from crushing.



Consider additional sound insulation measures before installing the boiler.

To reduce the noise, place the sound insulation strips (supplied with the boiler) below the base frame, flush with the front and back of the boiler.

- ▶ Position the boiler at its installation site.
- ▶ Place sound insulation strips lengthways below the boiler frame at all four corners.
- ▶ Carefully set the boiler down.

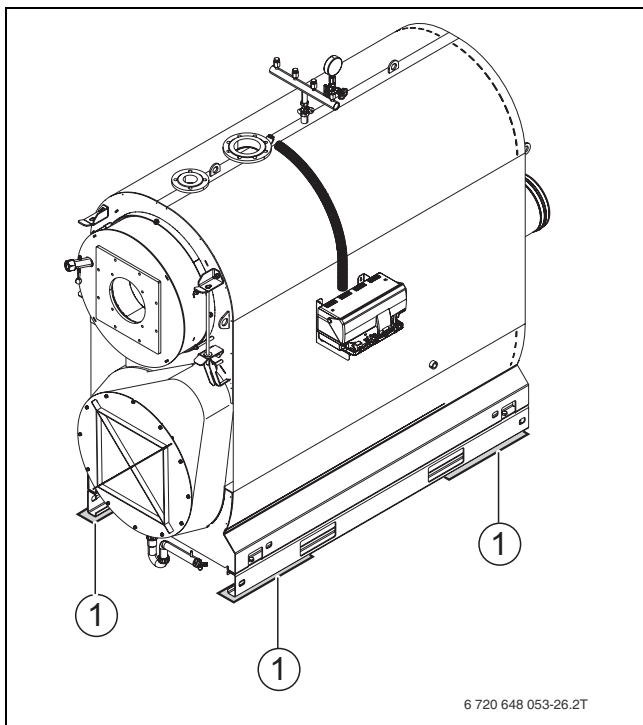

Fig. 10 Positioning the sound insulation strips

[1] Sound insulation strips

5.3 Levelling the boiler

To prevent air collecting in the boiler, level the boiler horizontally and vertically.



Use metal shims to level the boiler.

- ▶ Open the combustion chamber door (→ chapter 5.5.1, page 18).
- ▶ Place a spirit level on the combustion chamber floor.

- ▶ Level the boiler horizontally using the spirit level in the combustion chamber.

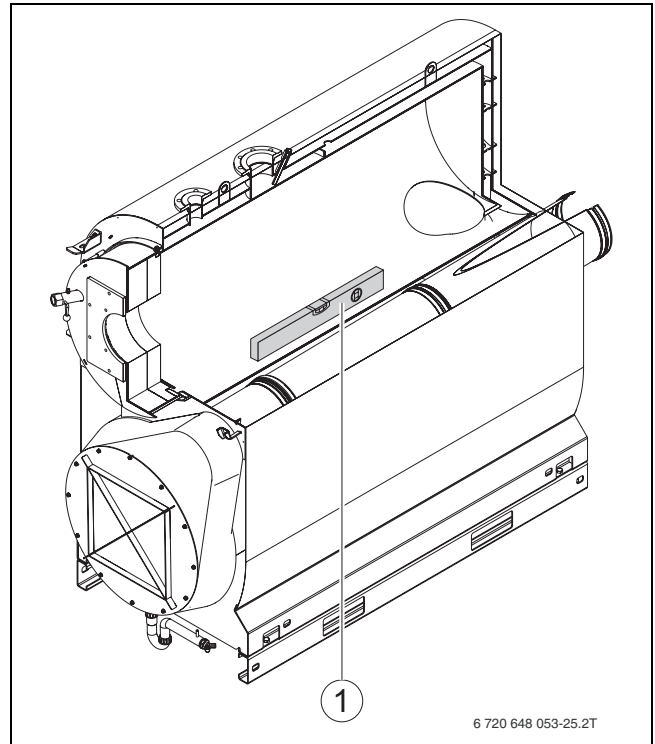

Fig. 11 Levelling the boiler

[1] Spirit level

5.4 Flue gas and water connections for heating system

5.4.1 General requirements of the flue system



DANGER: Risk to life through poisoning.

Insufficient ventilation can lead to dangerous flue gas leaks.

- ▶ Never close off or reduce the size of ventilation and extract air vents.
- ▶ Never operate the boiler unless faults are rectified.
- ▶ Inform the operator in writing of any faults and their associated risks.

Implementing the following recommendations to the installation of flue systems should guarantee trouble-free operation of the combustion system. Failure to observe these rules can result in substantial operating problems during combustion and may even result in explosions.

These are frequently acoustic disturbances, compromised combustion stability or excessive vibrations on assemblies or their components. Low NO_x combustion systems are to be viewed as being more sensitive to operating faults on account of their combustion control. Therefore, engineer and implement the flue system with particular care.

The flue system comprises a connection piece between the heat source and the vertical flue system itself (chimney).

When sizing and implementing the flue system, comply with the following requirements:

- Size flue systems in accordance with the respective national and local regulations and applicable standards.
- When selecting the material for the flue system, take the composition and temperatures of the flue gas into account to prevent damage and contamination of the system components that are in contact with flue gas.

- Only flue systems, which are approved for a flue gas temperature of at least 120 °C, may be used.
- Route the flue gas as directly as possible to the chimney considering the best possible flow characteristics (e.g. short, rising, and with the fewest possible bends). Provide a separate chimney flue for each boiler. Take the thermal expansion of the system into account.
- Implement deviations in the connection pieces as favourably as possible where flow is concerned by using bends or deflectors. Connection pieces with several deviations should be avoided, as they would have a detrimental effect on air-borne and structure-borne noise as well as the start-up pressure hammer. Prevent sharp-edged joints between rectangular connection flanges and the connection pipe. As with any reductions/expansions that may be required, the angle of the joint should not exceed 30°.
- Where possible, connection pieces should be joined to the chimney to provide optimum flow characteristics and with an incline (at an angle less than 45°). Any terminal pieces at the chimney outlets must ensure the free discharge of flue gas to atmosphere.
- Any condensate must be able to drain freely over the entire length, be treated and drained off in accordance with local regulations.
- Provide inspection apertures in accordance with local regulations, if necessary after discussion with the local authorising body.
- The chimney must be separated from the boiler (e.g. with compensators) to prevent the transfer of structure-borne noise.
- If a flue gas damper is installed in the flue system, integrate an "OPEN" limit switch into the boiler control system for safety reasons. Combustion must only be able to start when the feedback from the limit switch confirms that the flue damper is fully open. A temperature drop inside the boiler is possible on account of the time it takes the actuator to move the damper into position. Set the "CLOSE" limit position at the flue gas damper in such a way that it never closes fully. This prevents damage to the fitted burner through heat build up.

5.4.2 Fitting a sealing collar

- ▶ Fit the sealing collar in accordance with the installation instructions supplied.

5.4.3 Connecting the boiler to the pipework



NOTICE: System damage through leaking joints

- ▶ Connect pipes without stress to the boiler connections.



Boiler contamination on the water side is not permissible.
If required to prevent contamination, install a dirt trap in the boiler return.

Connecting the heating return

The boiler has two inlet options for the return water. If separate system returns for differing return temperatures are used (e.g. underfloor heating, DHW heating), these can be routed to the boiler via separate return connections.

- RK1 = Low return temperature (e.g. underfloor heating)
- RK2 = High return temperature (e.g. DHW heating)

On delivery, the return is sealed with a dummy flange. If using connection RK2:

- ▶ Remove dummy flange.

If there are no varying return temperatures, return connection RK1 is used.

- ▶ Connect the heating system return to the appropriate boiler return connection [5], [6].

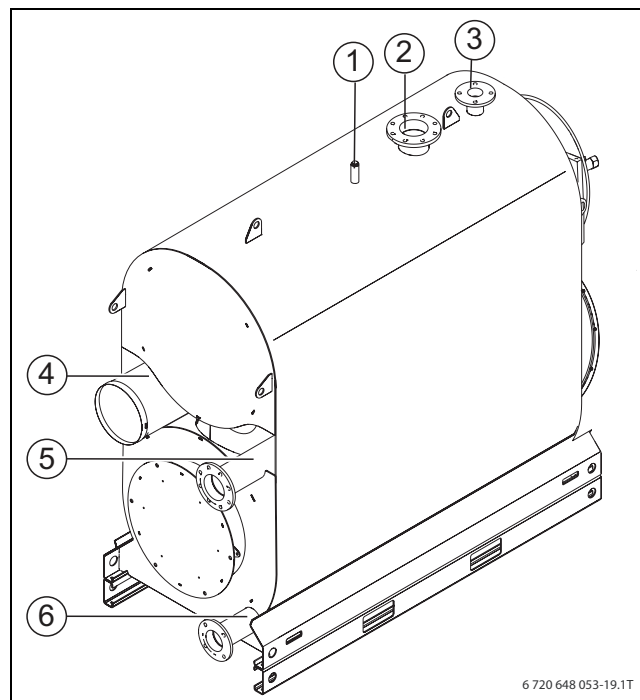

Fig. 12 Boiler connections

- [1] Fittings manifold connection
- [2] Boiler flow connection
- [3] Pressure release valve connection (VSL)
- [4] Flue connection
- [5] Boiler return connection 1 (RK1)
- [6] Boiler return connection 2 (RK2)

Connecting the heating flow

- ▶ Connect the heating system flow to the boiler flow connection [2].

Connecting the fittings column

- ▶ Connect the fittings manifold (accessory) to the fittings manifold connection [1].

Connecting the pressure release valve



NOTICE: System damage through connecting the wrong assemblies to the pressure release valve connection.

- ▶ Never connect a DHW cylinder or other heating circuit to the pressure release valve connection.

- ▶ Connect the safety valve to the pressure release valve connection (VSL) (→ Fig. 12, [3], page 17).

5.4.4 Information on condensate neutralisation



NOTICE: System damage through condensate.

- ▶ Always keep the condensate drain pipe clear.
- ▶ Ensure that the condensate drain pipe and neutralising system (where fitted) are working.



For the installation and maintenance of the neutralising system, see the special installation instructions (included in the standard delivery of the neutralising system).



The condensate can run into the boiler through the flue pipe. If this is not possible, only use stainless steel or plastic tees in the separate hose inlet.
With ceramic flue systems, fit a dirt trap.

- ▶ Push the siphon provided (condensate drain pipe) onto the pipe connector (→ Fig. 1, [5], page 6) on the flue gas collector.
- ▶ Tighten the union nut on the siphon.
- ▶ Connect the drain hose to the siphon connector using a hose clip.

5.4.5 Filling the boiler and checking connections for leaks



DANGER: Injury and/or system damage through overpressure when conducting the tightness test. Pressure, control and safety equipment may be damaged through excessive pressure.

- ▶ When carrying out the tightness test, ensure that no pressure, control or safety equipment is fitted that cannot be isolated from the boiler water chamber.



The test pressure level is subject to the system components and the heating network. Observe country-specific regulations and standards.

Before commissioning, check the heating system for tightness to ensure that no leaks will occur during operation.

- ▶ Fill the heating system with water (→ chapter 6.1, page 24 and chapter 6.2, page 24).
- ▶ Check all connections for leaks.
- ▶ Pressure test the heating system.
- ▶ Check the flange connection and boiler connections for leaks.
- ▶ Check the pipework for leaks.
- ▶ After the tightness test, reinstate all components that were taken out of operation.
- ▶ Ensure that all pressure, control and safety equipment is working correctly.

5.5 Opening and closing the combustion chamber door



WARNING: Risk of injury through falling combustion chamber door.

- ▶ Never undo all four nuts on the combustion chamber door.
- ▶ Retighten the nuts that secure the combustion chamber door two weeks after commissioning.

As standard, the combustion chamber door pivots open from left to right.

The following instructions assume the standard pivoting direction.

The combustion chamber door can be converted to open to the left.

5.5.1 Opening and closing the combustion chamber door

Opening the combustion chamber door

- ▶ Undo the four screws in the combustion chamber door.

- ▶ Pivot the combustion chamber door open.

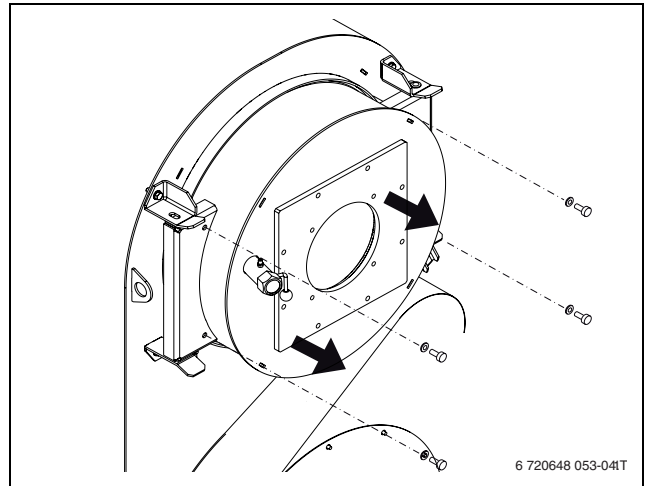

Fig. 13 Opening the combustion chamber door

Closing the combustion chamber door

- ▶ Pivot the combustion chamber door closed.
- ▶ Fit the four screws in the combustion chamber with washers.
- ▶ Tighten the screws diagonally with a torque of 40 Nm (use a torque wrench).

5.5.2 Refitting the door hinges



WARNING: Risk of injury from falling parts.

While the door hinges are being refitted, there is a risk of the combustion chamber door falling.

- ▶ Refit the door hinges before mounting the burner.
- ▶ Ensure that the combustion chamber door is closed and secured with the four screws.

The combustion chamber door swings open as standard from left to right (right hinged).

The following instructions are based on the standard opening direction. If the available space requires it, the combustion chamber door can be converted to left hinged.

Before starting work:

- ▶ Have the washer from the folder of technical documents to hand.
- ▶ Open the combustion chamber door (→ chapter 5.5.1, page 18).
- ▶ When closing the combustion chamber door, insert the washer between the combustion chamber door and the lower left hand door stay.
Ensure that the hole for the hinge pin is in line with the hole in the washer.
- ▶ Close the combustion chamber door.
- ▶ Fit the four screws in the combustion chamber door.
- ▶ Tighten the compression spring with the Allen screw until the rocker arm to the hinge pin has some play (→ Fig. 14, page 19).
- ▶ Remove retaining split pin [2] from hinge pin [1].

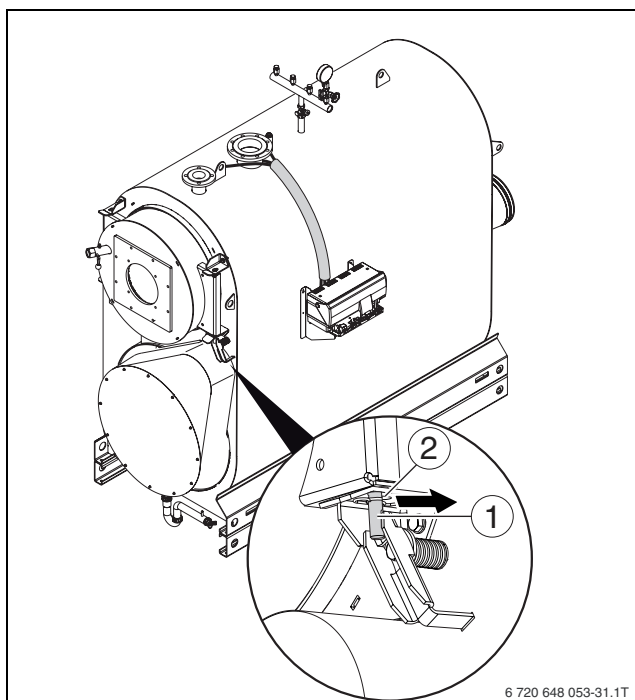

Fig. 14 Removing the retaining split pin

- [1] Hinge pin
- [2] Retaining split pin

- ▶ Pull the hinge pin (→ Fig. 14, [1]) upwards out of the hinge.
- ▶ Unhook the rocker arm (→ Fig. 15, [3]).
- ▶ Release the compression spring (→ Fig. 15, [1]) with Allen screw (→ Fig. 15, [4]).
- ▶ Remove the compression spring.
- ▶ Fit the compression spring on the left hand side.
- ▶ Fit the washer (→ Fig. 15, [2]).
- ▶ Fit the Allen screw.
- ▶ Pre-tighten the Allen screw until the washer has a clearance of 60 mm towards the boiler front panel.
- ▶ Hook in the rocker arm.
- ▶ Pivot the rocker arm over the compression spring.

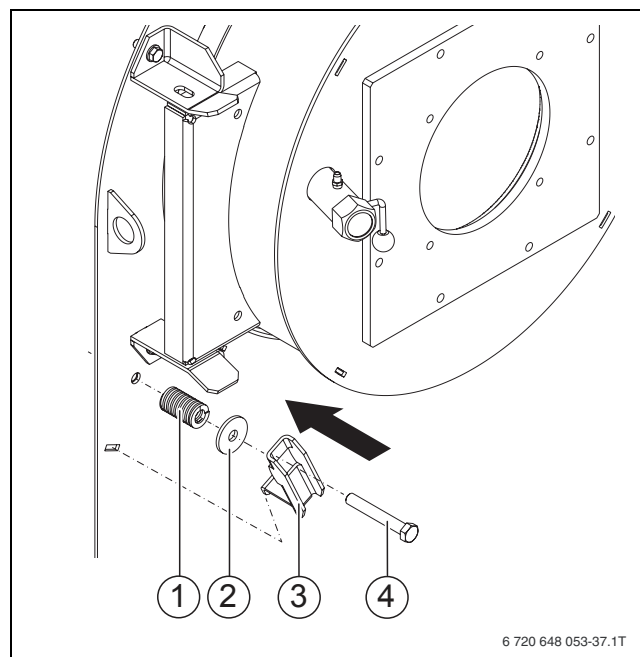

Fig. 15 Installation

- [1] Spring
- [2] Washer
- [3] Rocker arm
- [4] Screw

- ▶ Slightly undo the screws for the door stays on the left hand side until the door stays can be moved in the slot.
- ▶ Push the hinge pin on the left hand side from above through the hinge in the door stay and the door until it reaches the rocker arm.
- ▶ Fit the retaining split pin through the hinge pin below the lower door stay (→ Fig. 14).
- ▶ Push the upper door stay on the left hand side to the left and tighten the screws.
- ▶ Push the lower door stay on the left hand side to the right and tighten the screws.
The hinge pin has no more play and the combustion chamber door will not drop when opened.
- ▶ Remove the four door screws.
- ▶ Pivot the combustion chamber door open by 90°.
- ▶ Release the compression spring with the Allen screw until the hinge pin lies in the lower door stay at the front of the slot.
The combustion chamber door is hanging straight in the hinge.

5.6 Fitting the burner (accessory)



NOTICE: System damage through incorrect burner.

- ▶ Only use burners that meet the technical requirements of the Uni Condens 6000F (→ chapter 2.11, page 7).

5.6.1 Fitting the burner plate



Predrilled and undrilled burner plates are available (accessories).
The installation method depends on the particular burner used.

- ▶ Remove the protective plate from the combustion chamber door.
- ▶ Secure burner plate [3] with gasket [2] to combustion chamber door [1] using hexagon bolts and washers [4].

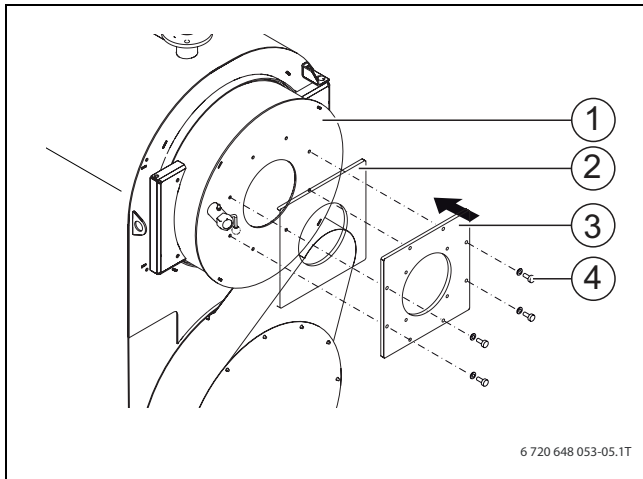

Fig. 16 Fitting the burner plate

- [1] Combustion chamber door
- [2] Seal
- [3] Burner plate
- [4] Hexagon screws and washers

5.6.2 Fitting the burner to the burner plate



DANGER: Injury/system damage through excess loads.

- ▶ Use suitable lifting gear for mounting the burner.



WARNING: Damage to health from inhaling fibre dust. Fibre dust may be inhaled when working on the thermal insulation.

- ▶ Wear a breathing mask when working on the thermal insulation.



NOTICE: System damage through incorrect or missing insulating rings.

- ▶ Only use the insulating rings supplied.



Refer to the installation instructions of the relevant burner for its mounting and connection.

As standard, the thermal insulation in the combustion chamber door has diameter of 270 mm for the blast tube. If the blast tube is larger than this, the diameter of the aperture can be increased to a maximum of 360 mm.

If the aperture in the thermal insulation of the combustion chamber door is increased, the insulating rings supplied will no longer fit (→ Fig. 18, [4], page 20).

If the blast tube diameter is greater than 360 mm, consult your supplier. If the blast tube is not long enough to reach the inner edge of the thermal insulation, a 45° chamfer can be applied to the thermal insulation.

The combustion chamber door must be opened to allow the burner to be mounted.

- ▶ Open the combustion chamber door (→ chapter 5.5, page 18).
- ▶ Push a gasket (→ Fig. 17, [2]) onto the burner connector.

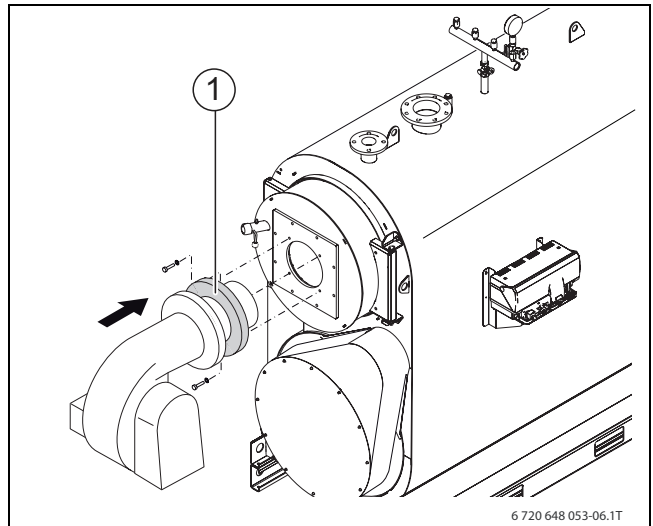

Fig. 17 Fitting the gasket

- [1] Seal

- ▶ Secure the burner to burner plate [2].
- ▶ Cut out insulating rings [4] in accordance with the diameter of blast tube [5].
- ▶ Fill the remaining gap on the inside of the combustion chamber door, between combustion chamber door insulation [3] and blast tube [5], with adapted insulating rings [4].

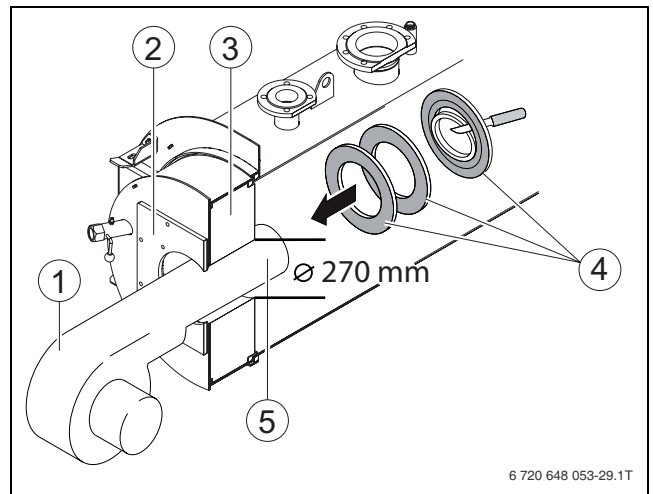

Fig. 18 Fitting the burner

- [1] Burner
- [2] Burner plate
- [3] Thermal insulation for combustion chamber door
- [4] Insulating rings
- [5] Blast tube

- ▶ Close the combustion chamber door and tighten the hexagon bolts (→ chapter 5.5, page 18).

5.7 Fitting and removing the front cover

- ▶ Hook lower front cover [3] into the retainers on the right hand and left hand side of the boiler casing.
- ▶ Hook upper right front cover [2] into the retainers on the boiler casing.
- ▶ Hook upper left front cover [1] into the retainers on the boiler casing.

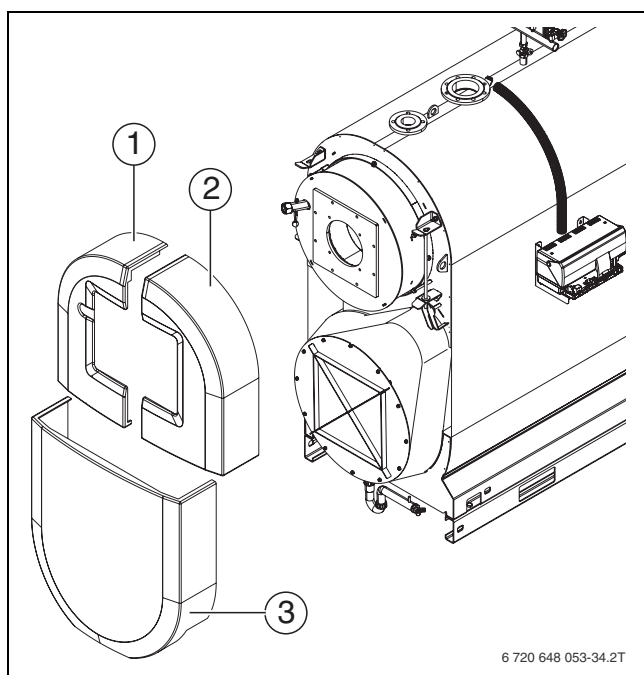

Fig. 19 Fitting the front cover

- [1] Upper left hand front cover
- [2] Upper right hand front cover
- [3] Lower front cover



To remove the front covers, proceed in reverse order.

5.8 Fitting the control unit (accessory)



We recommend fitting the control unit to the same side as the door hinges (factory-fitted on the right).

This chapter explains how to fit the CFB 840, 930, 910 and 930 control units and a temperature sensor set for the boiler.

The control unit can be fitted to a control unit support on the right hand or left hand side of the boiler. The control unit support is included in the standard delivery.

5.8.1 Fitting the control unit support and cable conduit



Install separate cable holders for on-site cables.

- ▶ Mark the installation height of the control unit support (→ Fig. 2, table 5, page 7).
- ▶ Trim and mark the cable conduit (→ Fig. 2, page 7).
- ▶ Drill holes (Ø 5 mm).
- ▶ Secure the cable conduit with the self-tapping screws supplied.
- ▶ Secure the control unit support with the self-tapping screws supplied.

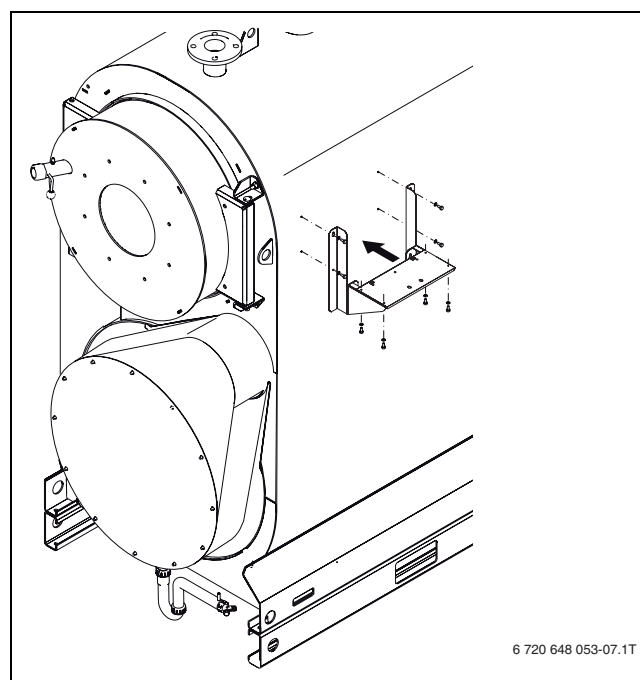

Fig. 20 Fitting the control unit support

5.8.2 Fitting the control unit

Fig. 21 shows the control unit and the front cover [1] from the back.

- ▶ Undo the screws in the cover [1].
- ▶ Lift off the cover.
- ▶ Insert the control unit at the front with locking tabs [4] into the holes in the control unit support.
- ▶ Pull the control unit forwards and then tip backwards. Flexible hooks [2] must latch into openings [3].
- ▶ Secure the base of the control unit to the control unit support with two screws.

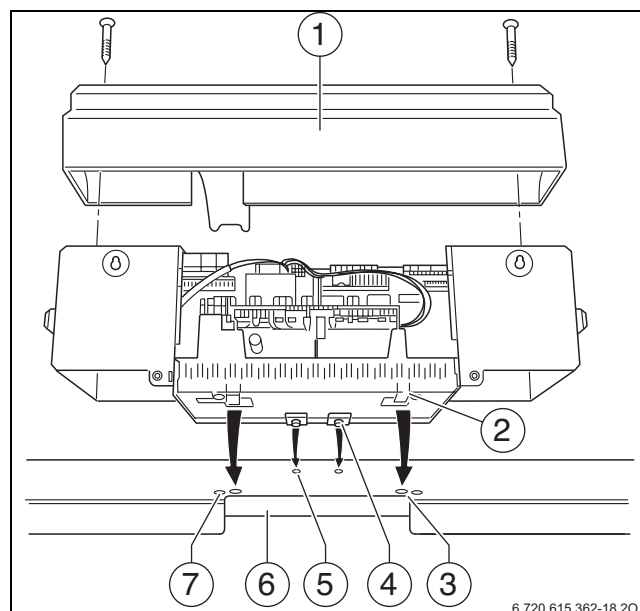

Fig. 21 Control unit

- [1] Cover
- [2] Flexible hooks
- [3] Rectangular apertures in the control unit support
- [4] Locking tabs
- [5] Oval slots in the control unit support
- [6] Control unit
- [7] Holes for screws

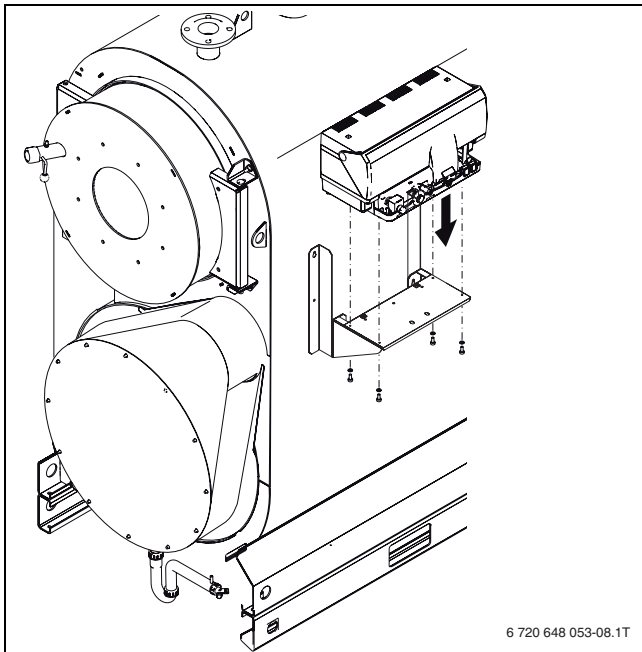

Fig. 22 Fitting the control unit

5.8.3 Making the electrical connection



DANGER: Danger to life through electric shock!

- ▶ Before opening the boiler, isolate the heating system across all life phases and secure against unintentional reconnection.
- ▶ Carefully route the cables/leads and capillary tubes.
- ▶ Ensure that capillaries are never kinked.
- ▶ Only carry out electrical work if you are a competent person. If you are not suitably qualified, arrange for a qualified electrician to make the electrical connections.
- ▶ Observe local installation regulations.
- ▶ Create a permanent connection in accordance with EN 50165/EN 60 335-2-102 or the applicable international installation standards and local regulations.



The locations of terminal strips on CFB control units are not identical. The terminal strip is easy to identify after the CFB control unit has been opened. The labelling of the terminal strip in the various control units is identical.

- ▶ Knock out or cut out the appropriate parts from the back panel (→ Fig. 24, [1]) as required.
- ▶ Route all cables and leads for connecting the temperature sensors and safety equipment via the cable conduit to the back of the control unit.
- ▶ Route all on-site cables to the control unit.
- ▶ Route sensor leads separately from other electrical cables.

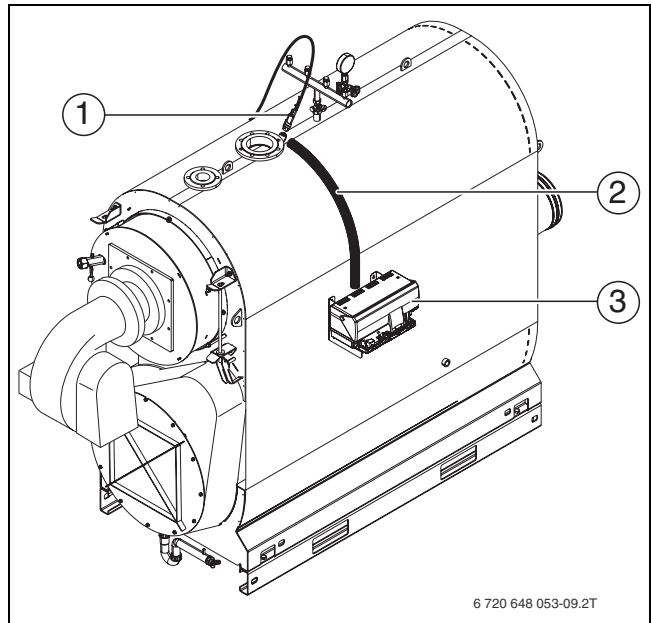

Fig. 23 Cable conduit at the control unit

- [1] Sensor well
- [2] Cable conduit
- [3] Control unit

- ▶ Make the plug-in connection in the control unit in accordance with the labelling on the terminal strip.
- ▶ Route the burner cable from below, behind the control unit support, to the control unit.
- ▶ Connect the burner cable to the control unit in accordance with the labelling on the plug-in connector strip.
- ▶ Secure the burner cable to the control unit support with the separate strain relief.
- ▶ Make on-site electrical connections to the appropriate plug-in connections according to the connection diagram (→ control unit documentation).

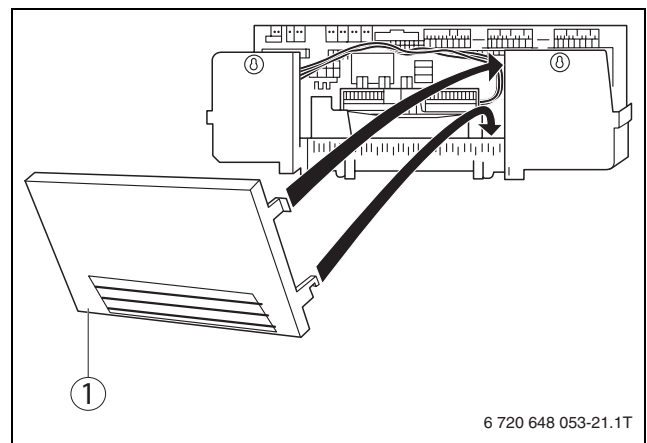

Fig. 24 Preparing the cable entry

- [1] Back panel section (CFB)]

Secure all cables with cable clips (part of the control unit standard delivery). Perform the following steps to secure the cables:

- ▶ Insert the cable clip together with the cable from the top into the slot in the frame.
- ▶ Slide the cable clip downwards.
- ▶ Counterhold.
- ▶ Flip the lever up.
- ▶ Fit the back panel.
- ▶ Refit the cover (→ Fig. 21, page 21) to the control unit.
- ▶ Fix the control unit cover with the screws supplied (Fig. 21, page 21).

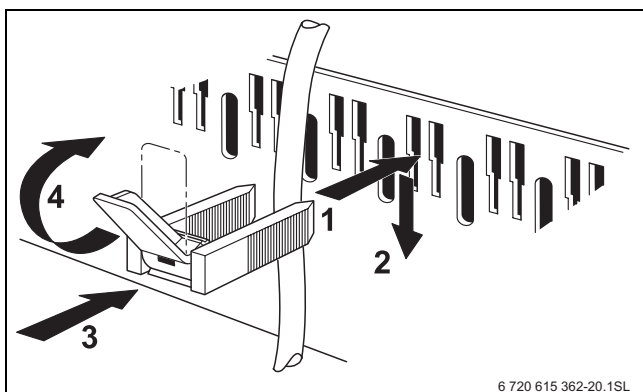

Fig. 25 Securing a cable with a cable clip

5.9 Fitting temperature sensors



NOTICE: System damage through damaged capillaries or incorrectly fitted temperature sensor.

- ▶ Ensure that the capillaries are neither kinked nor squashed when uncoiling and routing them.
- ▶ Always push the temperature sensor right to the bottom of the sensor well.



NOTICE: System damage due to incorrect sensor position!

The sensors of the safety cut-out (STB) and of the thermostat (TR) **must** be fitted at the installation site (→ picture 23, [1], page 22) on the top of the boiler.

- ▶ In the case of third party control units, match the sensor immersion sleeve to the diameter of the sensors used.
- ▶ Do not change the length of the immersion sleeve.



Standard immersion sleeve used: 3/4"

The boiler test point is at the top of the boiler body (→ 23, [1], page 22).

- ▶ Measure the depth of the sensor well.
- ▶ Mark the depth on the temperature sensor set (lead).
- ▶ **Insert the temperature sensor set as far as it will go into the test point (to the bottom).**
Use the mark to check whether the temperature sensors are correctly fitted.
- ▶ Secure the temperature sensor set in the test point with a sensor retainer.

The plastic coil [2] for keeping the temperature sensors together is pushed back automatically when it is inserted.



Insert compensating spring [1] between the temperature sensors to ensure a good contact between sensor well [4] and sensor surfaces, and thereby a reliable temperature transfer.

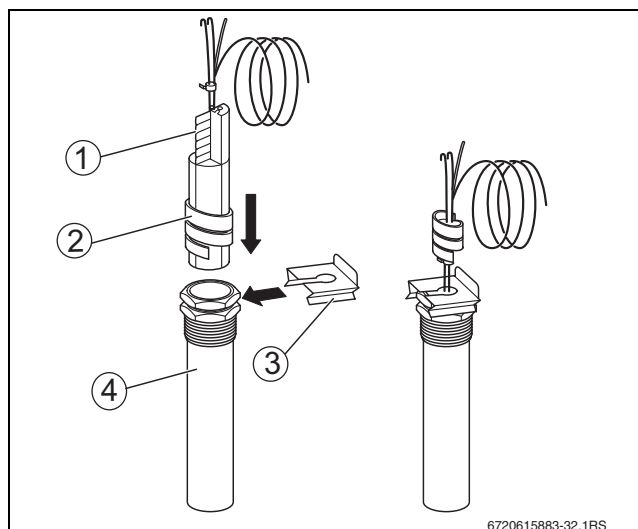

Fig. 26 Inserting the plastic coil into the sensor well

- [1] Compensating spring
- [2] Plastic spiral
- [3] Sensor retainer
- [4] Sensor well

- ▶ Never kink excess lengths of capillaries.
- ▶ Route the sensor lead through the cable conduit to the control unit.
- ▶ Connect the sensor lead to the control unit.

5.10 Routing the burner cable



Route the burner cable along the door hinge side (factory-fitted on the right).

- ▶ Route burner cable [4] from below, behind the control unit support, to the control unit (→ chapter 5.8.3, page 22).
- ▶ Connect burner cable [4] to control unit [3].
- ▶ Secure the burner cable with the external strain relief.
- ▶ Route the burner cable from the control unit to the burner.
- ▶ Connect burner cable [4] to the burner using the burner plug.

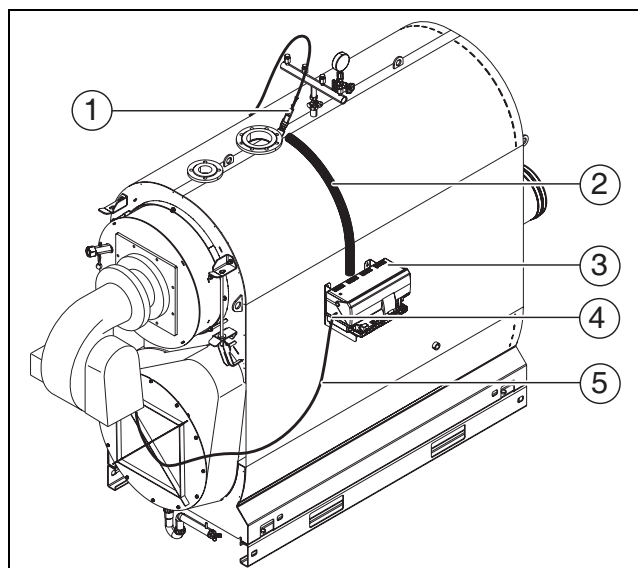

Fig. 27 Fitting the burner cable

- [1] Sensor well
- [2] Cable conduit
- [3] Control unit
- [4] Strain relief
- [5] Burner cable

6 Commissioning



NOTICE: Risk of boiler damage through contaminated combustion air.

- ▶ Never operate the boiler in very dusty conditions, e.g. if building work is taking place in the installation room.
- ▶ Ensure adequate ventilation.
- ▶ Never use or store chlorinated cleaning agents or halogenated hydrocarbons (as contained in spray cans, solvents or cleaning agents, paints and adhesives, for example) in the boiler room.
- ▶ A burner contaminated during building work must be cleaned before commissioning.

- ▶ Complete the commissioning report (→ chapter 6.6, page 25).

6.1 Flushing the heating system



If the heating system contains several heating circuits, these must be flushed one after the other.

To prevent contamination in the boiler, flush the heating system prior to commissioning.

- ▶ Flush the system prior to connection to the boiler.
- or-
- ▶ Isolate the heating flow and return at the boiler.
- ▶ Connect the heating flow to a water connection.
- ▶ Connect hose to the heating return of the heating system.
- ▶ Route hose from the heating return to a drain.
- ▶ Open connected consumers (e.g. radiators).
- ▶ Flush the heating system with fresh water until clear water emerges from the heating return.
- ▶ Drain the heating system.

6.2 Filling the heating system



NOTICE: System damage through temperature stresses.

- ▶ Only fill the heating system when cold (the flow temperature must not exceed 40 °C).
- ▶ During operation, only fill the heating system via the fill valve in the heating system pipework (return).



CAUTION: Health risk through contaminated drinking water.

- ▶ Observe all country-specific regulations and standards regarding the prevention of drinking water contamination. In Europe, observe standard.



Open the automatic air vent valve only briefly for venting.

The fill and top-up water quality must comply with the specifications in the operator's log supplied.

The pH value of the heating water increases after the heating system has been filled. After 3 – 6 months (initial service) check whether the pH value of the heating water has settled down.

- ▶ Adjust the pre-charge pressure of the expansion vessel to the required pressure (only for sealed unvented systems).
- ▶ Open the mixing and shut-off valves on the heating water side.

- ▶ Fill the heating system slowly and observe the pressure gauge whilst doing so.
- ▶ Vent the heating system via the radiator air vent valves.

If the water pressure drops as a result of venting the system:

- ▶ Top up the system with water.
- ▶ Carry out a leak test in accordance with locally applicable regulations.
- ▶ After the tightness test, reinstate all components that were taken out of operation.
- ▶ Ensure that all pressure, control and safety equipment is functioning correctly.

Once the boiler has been tested for tightness and no leaks have been found:

- ▶ Set the correct operating pressure.
- ▶ Close the automatic air vent valve.

6.3 Preparing the heating system for operation

Observe the following points during commissioning:

- ▶ Before commissioning, vent the heating system via the ventilation facilities provided for this purpose.
- ▶ Check that the inspection aperture on the flue gas collector is closed.
- ▶ Check that the combustion chamber door is securely closed.
- ▶ Check that the safety equipment (e.g. safety valve, minimum and maximum pressure limiters, high limit safety cut-out) is functioning correctly.
- ▶ Check that the required operating pressure has been achieved.
- ▶ Check the flange connections and other connections for tightness.
- ▶ Check the control unit connections and temperature sensor positions.
- ▶ Fill the condensate siphon.

6.4 Commissioning the control unit and burner

By commissioning the control unit you automatically commission the burner as well. The burner can then be started by the control unit. For further information, see the installation instructions of the relevant control unit or burner.

- ▶ Use the control unit to commission the boiler.
- ▶ Set the control unit parameters (→ chapter 6.5, page 25).
- ▶ Observe the commissioning times (→ chapter 6.1, page 24)
- ▶ Complete the commissioning report in the technical documentation of the burner.

6.5 Setting control unit parameters

The controller settings listed in table 14 apply to the CFB 910 and 930 control units.

For further information on setting the control unit, see chapter 3 from page 9.

Burner	Burner		Control unit setting	
	Gas	Burner type for fuel	Burner type to be selected	Fuel to be selected
Single fuel burner	Modulating		Modulating	Gas
	2-stage		2-stage	Gas

Table 14 Controller settings for CFB 910 and 930 control units

6.6 Commissioning report

The boiler can be operated with a gas burner.

- ▶ Carefully complete the commissioning report for the relevant gas burner.
- ▶ Sign all completed commissioning work and enter the date.

Commissioning steps	Page (individual steps)	Comments (signature)
1. Flush the heating system.	Page 24	
2. Fill the heating system with water.	Page 24	
3. Vent the heating system.		
4. Carry out tightness test.	Page 18	
5. Switch on the control unit. ▶ Boiler-specific parameters set and recorded.	See technical documentation on the control unit as well as the specification, chapter 3.8, page 10 and chapter 6.5, page 25.	
6. Ensure the function of all safety equipment.		
7. Check the fuel line for tightness.		
8. Start the burner.	See technical burner documentation.	
9. Complete the burner test report regarding the individual output stages.		
10. Conduct a tightness test on the hot gas side. After a short time in operation, tighten the screws in the combustion chamber door to prevent leakage around the door as a result of the packing cord settling.		
11. Check the flange connections and fitting after the boiler has been heated up and retighten.		
12. Check flue path for tightness.		
13. Check the flue gas temperature.		
14. Carry out a function test on all safety equipment and record this.		
15. Instruct the system user and hand over technical documentation.		
16. Enter the fuel used in the table (→ "General" operating instructions).		
17. Confirm commissioning by a competent person.		
Company stamp/signature/date		

Table 15 Commissioning report

7 Shutting down



NOTICE: Risk of system damage through frost. When there is a frost, the heating system can freeze up if it is not operational, e.g. because of a fault shutdown.

- ▶ When there is a risk of frost, protect your heating system against freezing up.
- ▶ If your heating system has been shut down for several days due to a fault shutdown and there is a risk of frost, drain the heating water at the drain & fill valve. Also leave the air vent valve at the highest point in the system open.



NOTICE: Risk of system damage through frost. The heating system can freeze up as a result of a power failure or if the power has been switched off.

- ▶ Check the "Control unit settings" to ensure the system remains operational (especially when there is a risk of frost).

7.1 Shutting down the heating system

Shut down your heating system via the control unit. Switching off the control unit also switches off the burner automatically.

- ▶ Set the On/Off switch of the control unit to "0" (Off).
- ▶ Isolate the fuel supply to the burner.

7.2 Shutting down the heating system in an emergency



Only in emergencies, switch OFF the heating system via the boiler room MCB/fuse or the heating system emergency stop switch.

- ▶ In dangerous situations, immediately close the main fuel shut-off valve and the power supply of the heating system via the boiler room main MCB/fuse or the heating system emergency stop switch.
- ▶ Isolate the fuel supply to the burner.
- ▶ Never put your life at risk. Your own safety is paramount.

8 Inspection and maintenance

8.1 General notes



NOTICE: System damage due to inadequate cleaning and maintenance.

- ▶ Carry out cleaning and maintenance at least once a year. In the course of this work, check the entire heating system including the neutralising system for correct function.
- ▶ Immediately correct all faults to prevent system damage.



Annual inspection and service are part of the warranty terms.



Use only original, genuine spare parts from the manufacturer. Spare parts can be ordered from the manufacturer's spare parts catalogue.

Offer your customer an annual contract covering inspection and responsive service. For the work covered by such a contract, see chapter 8.5 "Inspection and maintenance reports", page 30.

8.2 Preparing the boiler for inspection and maintenance



DANGER: Risk to life from electric shock when the heating system is open.

- ▶ Prior to opening the heating system: Isolate the heating system from the mains power supply via the heating system emergency stop switch or the corresponding domestic MCB/fuse.
- ▶ Safeguard the heating system against unintentional reconnection.



DANGER: Risk to life through explosion of flammable gases!

- ▶ Work on gas components must only be carried out by a competent person.



If gas lines have to be detached from the gas burner, the combustion chamber door may only be opened by a competent person.

- ▶ Shut down the heating system (→ chapter 7.1, page 26).

Prior to opening the combustion chamber door:

- ▶ Check the general condition of the heating system.
- ▶ Visual inspection and function check of the heating system.
- ▶ Check all system parts that carry fuel or water for leaks and visible corrosion.
- ▶ Open the combustion chamber door (→ chapter 5.5.1, page 20).

8.3 Cleaning the boiler

8.3.1 Preparing the boiler for cleaning with brushes



CAUTION: Risk of injury through falling parts.

- ▶ Prior to opening the doors, ensure that the hinge pin is correctly fitted in the combustion chamber door and secured with a spring washer.

- ▶ Remove the front cover (→ chapter 5.7, page 21).
- ▶ Remove the burner.
- ▶ Open the combustion chamber door (→ chapter 5.5, page 18).
- ▶ Clean the combustion chamber and the heating surfaces.
- ▶ Open the flue gas collector cover (→ chapter 8.3.5, page 28).
- ▶ Open the reversing chamber cover (→ chapter 8.3.5, page 28).
- ▶ Check the flue gas collector and condensate drain, and clean via the inspection aperture if required.

8.3.2 Cleaning the boiler with cleaning brushes



WARNING: System damage through using incorrect cleaning equipment.

- ▶ If cleaning with a brush, use only original cleaning brushes from the manufacturer.
- ▶ When cleaning only use brushes made of nylon or of stainless steel with a stainless steel linkage.

- ▶ Clean the heating surfaces of the combustion chamber (→ Fig. 28, [1], page 27) with the cleaning brush (→ Fig. 28, [2], page 27).

- ▶ Remove any cleaning residues with a vacuum cleaner.
- ▶ Check the seals around the boiler door, reversing chamber and flue gas collector, and replace if required.
- ▶ Close and secure the combustion chamber door.

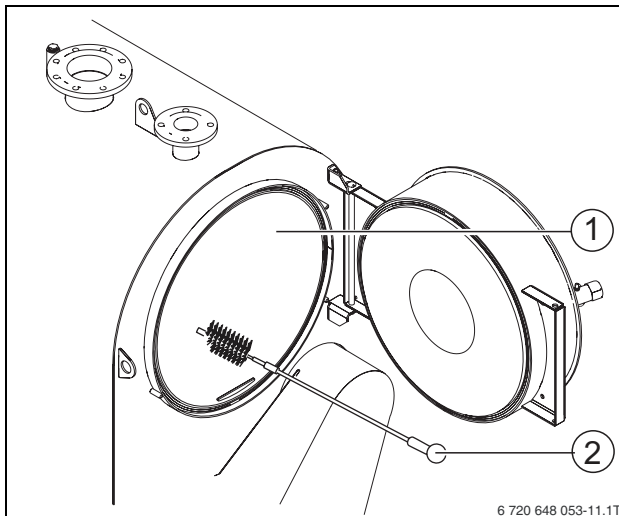

Fig. 28 Cleaning the heating surfaces

- [1] Combustion chamber (heating surfaces of combustion chamber)
- [2] Cleaning brush

8.3.3 Cleaning the reversing chamber



Remove casing sections from the boiler as the cleaning cover is located underneath.



If you do not push the whole bristle part of the cleaning brush right through the secondary heating pipe, you will find it very difficult to remove the brush from the pipe.

- ▶ Push the bristle part of the cleaning brush right through the secondary heating pipe until the bristles emerge at the other end of the pipe.

To be able to remove combustion residues from the reversing chamber, remove the reversing chamber cover. This is located at the back of the boiler.

- ▶ Remove the casing and insulation.
- ▶ Undo the nuts and washers in the reversing chamber cover.
- ▶ Remove the reversing chamber cover.

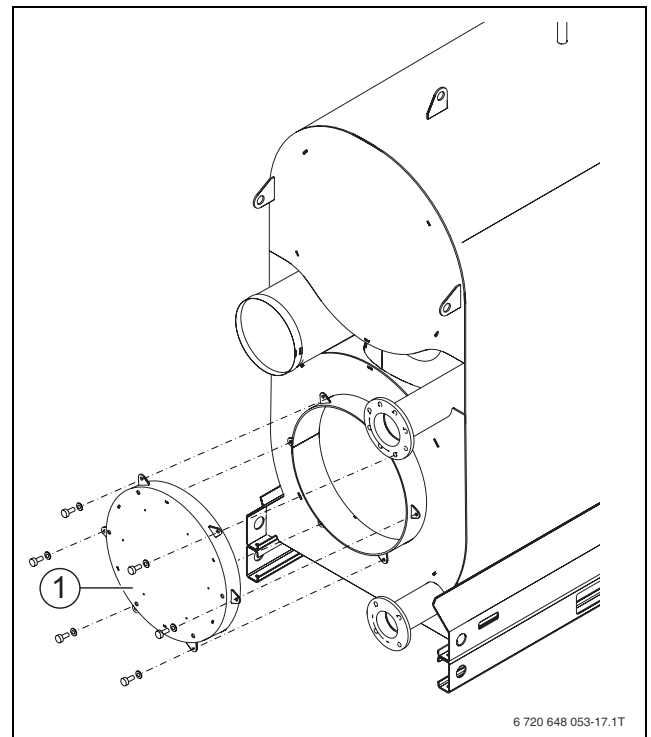

Fig. 29 Removing the reversing chamber cover

- [1] Reversing chamber cover

- ▶ Undo the nuts and washers in the flue gas collector cover.
- ▶ Remove the cover.
- ▶ Clean the secondary heating pipes with a brush (→ Fig. 30, page 27).
- ▶ Remove all loose combustion residues from the combustion chamber (→ Fig. 28, [1]), the hot gas flues and the reversing chamber (→ Fig. 29,[1]).

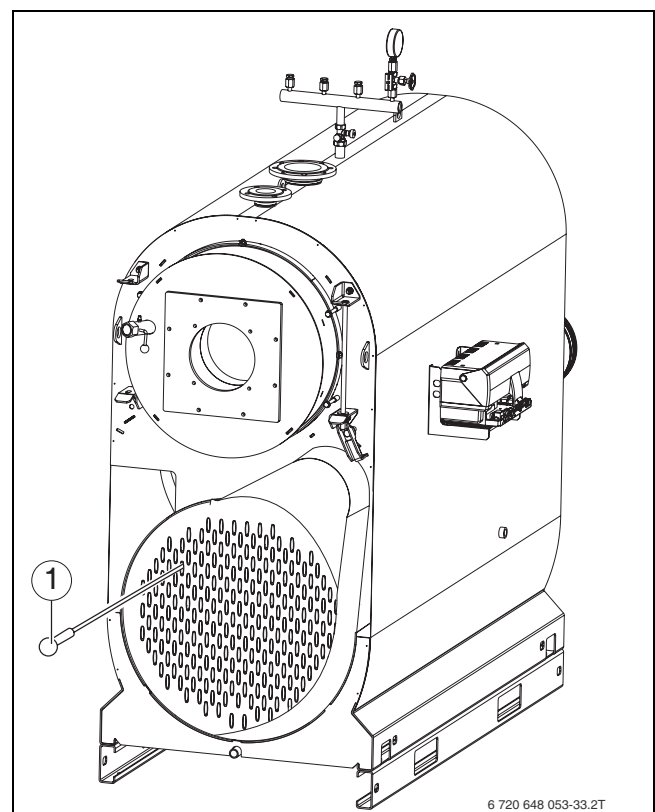

Fig. 30 Cleaning the flue gas collector

- [1] Cleaning brush

8.3.4 Replacing the flue gas collector gasket



Replace the gasket in the flue gas collector cover during the annual service.

- ▶ Remove the old gasket and adhesive residues.
- ▶ Trim the new gasket.
- ▶ Affix the new gasket directly to the edge of the flue gas collector.
- ▶ Allow abutting edges to overlap.
- ▶ Cut off abutting edges at an angle of 45°.
- ▶ Press diagonally abutting edges together leaving no gap.

8.3.5 Fitting the covers to the flue gas collector and reversing chamber



DANGER: Risk of poisoning through escaping gases. Flue gas can escape during operation if the flue gas collector and condensate drain pipe are not correctly sealed.

- ▶ Carefully seal the flue gas collector with its inspection cover and the condensate drain pipe with the siphon and hydraulic seal.

- ▶ Check the reversing chamber gasket for damage and replace if required.
- ▶ Position the flue gas collector cover.
- ▶ Tighten the nuts with a torque of 15 Nm.
- ▶ Position the reversing chamber cover and secure tightly.
- ▶ Secure lagging mat.
- ▶ Mount the burner.
- ▶ Mount the front cover.
- ▶ Restart the heating system.

8.3.6 Wet-cleaning the boiler



NOTICE: System damage through moisture in the control unit. If moisture enters the control unit, it will be damaged. Never allow any spray to enter the control unit.

- ▶ Ensure that you only spray cleaning agent onto the heating surfaces of the hot gas flues and the combustion chamber.



NOTICE: System damage through cleaning agents in connected components. If liquids displaced by the cleaning agents are channelled through connected components, e.g. siphon, neutralising system etc., these components may become inoperable or be damaged.

- ▶ Protect or remove connected components.



For wet cleaning (chemical cleaning), observe the operating instructions and safety instructions of the cleaning equipment and cleaning agent. For wet cleaning, ensure that the cleaning agent is chloride-free.

- ▶ Observe the safety instructions of the cleaning agent.

When wet-cleaning, use a cleaning agent appropriate for the level of contamination.

For wet cleaning, proceed according to the manufacturer's instructions.

Liquid cleaning residues can be drained off through the condensate drain pipe on the flue gas collector.

- ▶ Disconnect the heating system from the power supply.
- ▶ Close the fuel supply.
- ▶ Disconnect the neutralising system and siphon prior to wet cleaning.
- ▶ Cover the control panel with foil to prevent spray from entering it.
- ▶ Clean the boiler according to the instructions of the cleaning equipment manufacturer.

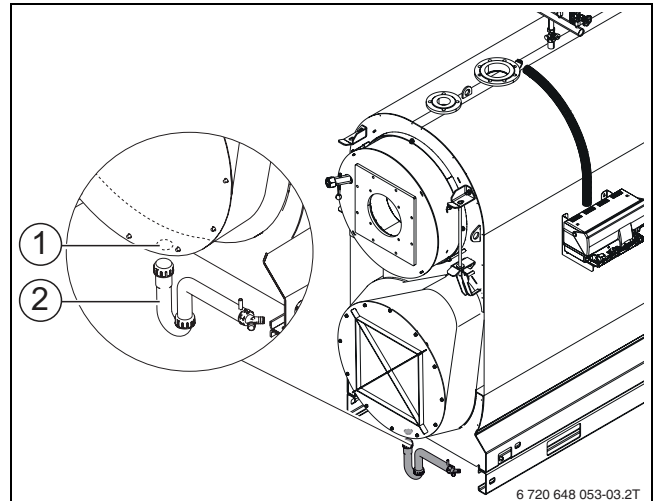

Fig. 31 Opening/closing the cleaning drain

- [1] Dummy cap for cleaning drain
- [2] Cleaning drain

After cleaning:

- ▶ Reconnect the condensate drain pipe.
- ▶ Reconnect the condensate connection.
- ▶ Check the seals around the combustion chamber door and flue gas collector, and replace if required (→ chapter 8.3.4 and chapter 8.3.5, page 28).
- ▶ Close and secure the combustion chamber door.
- ▶ Close and tightly seal the flue gas collector (→ chapter 8.3.4 and chapter 8.3.5, page 28).
- ▶ Continue to ensure adequate ventilation of the boiler room.
- ▶ Remove the foil from the control unit.
- ▶ Restart the heating system.

8.4 Checking and correcting the water pressure

The heating system must contain sufficient water to safeguard its correct function.

- ▶ If the water pressure in the heating system is too low, top up with water.
- ▶ Check the water pressure monthly.

8.4.1 When should you check the water pressure in the heating system?



The fill and top-up water quality must comply with the specifications in the operator's log supplied.



Air pockets may form in the heating system through the fill or top-up water releasing gases.

- ▶ Vent the heating system (e.g. bleeding the radiators).
- ▶ If required, top up with water.

Recently added fill or top-up water loses much of its volume in the first few days because it releases gases. With new systems you should therefore initially check the heating water pressure on a daily basis, and then at gradually longer intervals.

- Once the heating system is hardly losing any volume, check the heating water pressure monthly.

A distinction is generally made between open vented and sealed unvented systems. In practice, open vented systems are hardly installed nowadays. We will therefore be using a sealed unvented heating system to demonstrate how you can check the water pressure. All settings will have already been made by the installation engineer when the system was first commissioned.

8.4.2 Sealed unvented systems



NOTICE: System damage through frequent topping up. Subject to the water quality, your heating system can be damaged through corrosion or scaling.

- ▶ Ensure that the heating system is vented correctly.
- ▶ Check the heating system for leaks and the expansion vessel for functionality.
- ▶ Observe the requirements regarding water quality (see operator's log).
- ▶ If water loss occurs frequently, locate the cause and rectify the problem without delay.



NOTICE: System damage through temperature stresses.

- ▶ Only fill the heating system when cold (the flow temperature must not exceed 40 °C).
- ▶ During operation, only fill the heating system via the fill valve in the heating system pipework (return).

For sealed unvented systems, the pressure gauge needle [3] must be within the green band [2]. The red needle [1] of the pressure gauge must be set to the pressure required for the heating system.

- ▶ Check the heating system water pressure.
- ▶ Top up the heating water if the pressure gauge needle [3] drops below the green band [2].
- ▶ Top up with water via the filling valve in the heating system pipework.
- ▶ Vent the heating system.
- ▶ Check the water pressure once more.

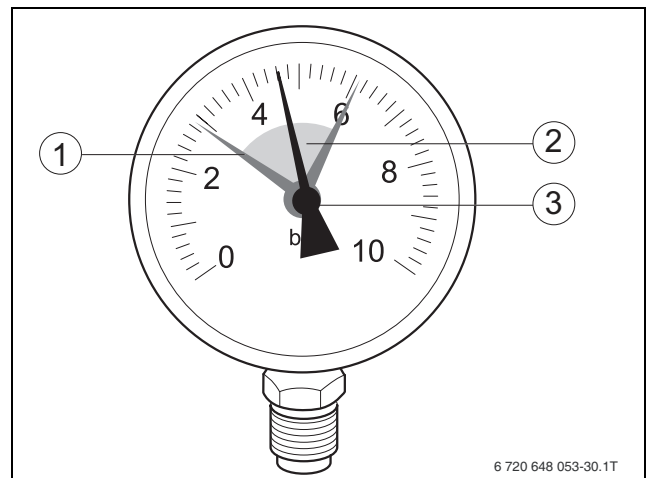

Fig. 32 Manometer for sealed unvented heating systems

- [1] Red needle
- [2] Green marking
- [3] Pressure gauge needle

8.4.3 Installations with automatic pressurisation units

For installations where a pressurisation unit is integrated, observe the manufacturer's instructions.

The water quality requirements also apply here (→ chapter 8.4.1, page 29).

8.5 Inspection and maintenance reports

The inspection and maintenance reports provide an overview of the required inspection and service steps that should be carried out annually.

Complete these reports after inspections and service. The report can also be used as copying template.

- ▶ Sign and date the completed inspection work.



Warranty:
Annual inspection and service are part of the warranty terms.

Inspection work	Page (individual steps)	Notes
1. Check the general condition of the heating system (visual inspection).		
2. Check the heating system function.		
3. Check the components in contact with fuel and water throughout the system for the following: <ul style="list-style-type: none"> • Tightness • Visible signs of corrosion • Signs of ageing 		
4. Check the combustion chamber and heating surface for contamination and clean them. For this, shut down the heating system.	Page 26	
5. Check gaskets/packing cords on combustion chamber door and replace if required.		
6. Check and clean the burner. <ul style="list-style-type: none"> ▶ Visual inspection and remove any contamination. ▶ Check all safety equipment (safety shutdown). ▶ Function check ▶ Flue gas analysis with test report for each output stage. 	See technical burner documentation.	
7. Check the flue for function and safety.	See technical burner documentation.	
8. Check the hydraulic seal of the condensate siphon and replace if required.		
9. Check the water pressure and pre-charge pressure of the expansion vessel.	Page 28	
10. Check the control unit settings are suitable and adjust if required.	See technical control unit documentation.	
12. Test all safety equipment (safety shutdown) and record findings. For example: <ul style="list-style-type: none"> ▶ High limit safety cut-out ▶ Pressure limiter min. ▶ Pressure limiter max. (if installed) ▶ Other safety equipment. 		
13. Conduct a water analysis and record the results in the operator's log: <ul style="list-style-type: none"> ▶ pH value ▶ Residual hardness ▶ Oxygen binder ▶ Phosphate ▶ Electrical conductivity ▶ Appearance ▶ Check water records (e.g. amount of top-up water) in the operator's log. 		
14. Check the neutralisation system.		
15. Final check of the inspection work, take measurements and record values and test results.		

Table 16 Inspection report

Confirm professional inspection with signature, date and company stamp.

Table 17

	Responsive maintenance	Page (individual steps)	Notes
1.	Shut down the heating system.	Page 26	
2.	Clean the combustion chamber.	Page 26	
3.	Clean hot gas flues (heating surfaces).	Page 26	
4.	Check gaskets/packing cords on the combustion chamber door, inspection apertures in the reversing chamber and flue gas collector, and replace if required.		
5.	Check that the condensate drain pipe is clean and filled with a hydraulic seal.		
6.	Check the neutralisation system.	See technical documentation of the neutralising system	
7.	Start up the heating system.	Page 24	
8.	Final check of the maintenance work, take measurements and record values and test results.	See technical burner documentation.	
9.	Check the function and operational safety (safety equipment).		

Table 18 Heating system maintenance report

Confirm professional maintenance with signature, date and company stamp.

Table 19

9 Correcting a burner fault



NOTICE: Risk of system damage through frost. When there is a frost, the heating system can freeze up if it is not operational, e.g. because of a fault shutdown.

- ▶ If your heating system has been shut down for several days due to a fault shutdown and there is a risk of frost, drain the heating water at the drain & fill valve. For this, the automatic air vent valve at the highest point in the heating system must also be open.



NOTICE: System damage from pressing the reset button too frequently. This can damage the burner ignition transformer.

- ▶ Press the reset button no more than three times in a row.

The display shows heating system faults. Further information on the fault displays can be found in the service instructions of the relevant control unit. In addition, burner faults are shown on an indicator on the burner.

- ▶ Press burner reset button (see burner operating instructions).
- If the burner still fails to start after three attempts, contact a contractor.

10 Environmental protection/disposal

Environmental protection is a key commitment of the Bosch Group. Quality of products, efficiency and environmental protection are equally important objectives for us. All legislation pertaining to the environment is strictly observed. To protect the environment we use the best possible technology and materials, subject to economic considerations.

Packaging

We are dedicated to adhering to country-specific disposal standards for packaging in order to ensure optimum recycling. All packaging materials are environmentally compatible and can be recycled.

Old appliance

Old appliances contain materials that should be recycled. The relevant assemblies are easy to separate, and all plastics are identified. This allows the various assemblies to be appropriately sorted for recycling or disposal.

11 System examples

11.1 Layout of the minimum equipment for technical safety in accordance with EN 12828; operating temperature $\leq 105\text{ }^{\circ}\text{C}$; cut-out temperature (STB) $\leq 110\text{ }^{\circ}\text{C}$

The schematic representation shows the minimum equipment for technical safety in accordance with EN 12828 for the system versions designated here – without claim of completeness.

Practical implementation is subject to currently applicable technical rules.

Boilers $> 300\text{ kW}$; operating temperature $\leq 105\text{ }^{\circ}\text{C}$; shutdown temperature (STB) $\leq 110\text{ }^{\circ}\text{C}$

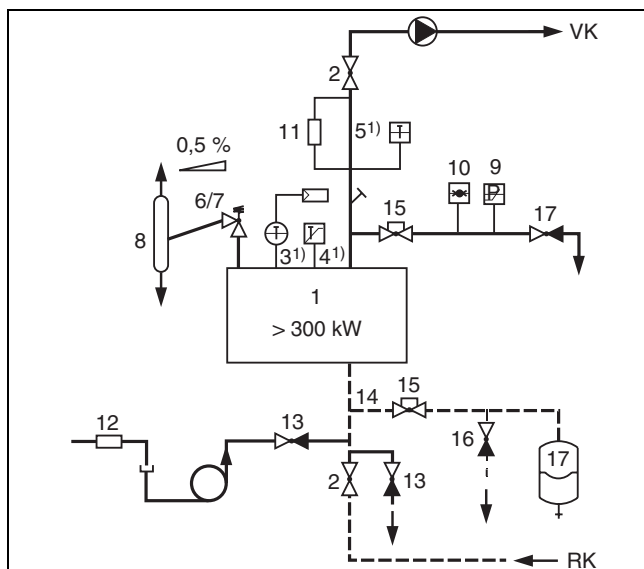

Fig. 33 Safety equipment to EN 12828 for boilers $> 300\text{ kW}$ with high limit safety cut-out $\leq 110\text{ }^{\circ}\text{C}$ (direct heating)

Key to Fig. 33:

- [RK] Return
- [VK] Boiler flow
- [1] Heat source
- [2] Shut-off valve, flow/return
- [3] Temperature regulator
- [4] High limit safety cut-out
- [5] Temperature indicator
- [6] Diaphragm safety valve 2.5 bar/3 bar or
- [7] Lifting spring safety valve = $> 2.5\text{ bar}$
- [8] Flash trap in systems $> 300\text{ kW}$; not required if an additional high limit safety cut-out with shutdown temperature $\leq 110\text{ }^{\circ}\text{C}$ and an additional maximum pressure limiter are provided for each boiler instead.
- [9] Maximum pressure limiter
- [10] Pressure gauge
- [11] Low water safety limiter. Alternatively one minimum pressure limiter or a replacement measure approved by the manufacturer for each boiler.
- [12] Non-return valve
- [13] Drain & fill valve (DFV)
- [14] Expansion line
- [15] Shut-off valve with lockout against unintentional closure (e.g. lock shield valve)
- [16] Drain upstream of the expansion vessel
- [17] Expansion vessel (to EN 13831)

- 1) Standard equipment level of the boiler control unit: The maximum achievable flow temperature in combination with CFB control units is approx. 18 K lower than the shutdown temperature (high limit safety cut-out).

Keyword index

A	
About the appliance	4
Appliance description	5
CE Declaration of Conformity	4
Correct use	4
Operating conditions	4
Overview of possible fuels	5
Scope of supply	4
Accessories	4
Appliance description	5
Assembly aids	5
B	
Boiler cover	21
Burner	19
Burner cable	23
Burner plate	19
C	
CE Declaration of Conformity	4
Check all connections for leaks	18
Checking and correcting the water pressure	28
checking and correcting the water pressure in sealed unvented systems	29
Cleaning	26
Combustion chamber door	18
Commissioning	24
Commissioning the burner	24
Commissioning the control unit	24
Filling the heating system	24
Flushing the heating system	24
Preparing the heating system for operation	24
Commissioning report	25
commissioning the burner	24
commissioning the control unit	24
Connecting the boiler to the pipework	17
Connection on the flue gas and water sides	16
Control unit	21
Correct use	4
D	
Data plate	5
Dimensions	7
Disposal	32
E	
Electrical connection	22
Environmental protection	32
Explanation of symbols	3
F	
Filling the boiler	18
filling the heating system	24
Fitting sensors	23
Fitting the boiler front cover	21
Fitting the burner	19
Fitting the burner plate	19
fitting the burner to the burner plate	20
Fitting the control unit	21
Flue gas and water connections for heating system	16
Flue gas collector	27
Flue pipe sealing collar	17
flushing the heating system	24
Fuels	5
G	
Guidelines	9
H	
Heating flow	17
Heating return	17
I	
Inspection	26
Inspection and maintenance	26
Checking and correcting the water pressure	28
Checking and correcting the water pressure in sealed unvented systems	29
Cleaning heating surfaces and turbulators with a cleaning brush	26
Cleaning the boiler	26
Cleaning the flue gas collector	27
Fitting the cleaning cover	28
General information	26
Preparing the boiler	26
Wet-cleaning the boiler	28
Inspection cover	28
Inspection report	30
Inspection reports	30
Installation	15
Check all connections for leaks	18
Connecting the boiler to the pipework	17
Filling the boiler	18
Fitting sensors	23
Fitting the boiler front cover	21
Fitting the burner	19
Fitting the burner plate	19
Fitting the burner to the burner plate	20
Fitting the control unit	21
Flow safety line	17
Flue gas and water connections for heating system	16
Heating flow	17
Heating return	17
Levelling the boiler	16
Making the electrical connection	22
Recommended wall clearances	15
Routing the burner cable	23
Siting the boiler	15
Sound insulation mats	16
L	
Levelling	16
Levelling the boiler	16
M	
Maintenance report	30
Maintenance reports	30
Making the electrical connection	22
Minimum wall clearances	15
N	
Neutralisation	17
O	
Old appliance	32
Operating conditions	4
Overview of Uni Condens 6000F	6

P	
Packaging	32
Preparing the heating system for operation	24
Prior to commissioning	
Converting the combustion chamber door	18
Opening the combustion chamber door	18
Product description	5
R	
Recommended wall clearances.....	15
Recycling	32
Regulations	9
Routing the burner cable	23
S	
Safety equipment	4
Safety instructions	3
Safety pipe flow	17
Scope of supply	4
Service	26
Setting parameters.....	25
Shut down the heating system.....	26
Shutdown	
Shutting down the heating system in emergencies	26
Shutting down	26
Shut down the heating system	26
shutting down the heating system in emergencies	26
Siting.....	15
Siting the boiler.....	15
Sound insulation mats.....	16
Standards	9
System examples	32
T	
Technical Data	7–8
Dimensions.....	7
Output data	8
Temperature sensor	23
Tools	5
Transport.....	13
Heavy duty rollers	14
Lifting with a crane.....	13
Moving the boiler with a forklift truck	13–14
Moving the boiler with two pallet trucks.....	13–14
Type overview.....	4
W	
Water pressure	28

Notes



United Kingdom

Bosch Thermotechnology

Cotswold Way, Warndon, Worcester WR4 9SW
All Enquiries: 0844 892 3004

<http://www.boschthermotechnology.co.uk/>

Australia

Robert Bosch (Australia) Pty Ltd
1555 Centre Rd
Clayton, VIC 3168
Phone 1300 30 70 37
Fax 1300 30 70 38
www.bosch.com.au/hotwater

New Zealand

Phone 0800 4 Bosch or 08 543 352
www.bosch.co.nz