



Hydronic Gas Condensing Boiler

# Condens 5000 W

ZSB 30-2 A ...| ZWB 37-2 A ...



**BOSCH**

Installation and servicing instructions for contractors

# Contents

<b>1</b>	<b>Key to symbols and safety instructions</b>	<b>5</b>	<b>8</b>	<b>Commissioning</b>	<b>35</b>
1.1	Explanation of symbols	5	8.1	Before commissioning	36
1.2	Safety instructions	5	8.2	Switching the appliance on/off	36
<b>2</b>	<b>Standard delivery</b>	<b>6</b>	8.3	Starting the central heating	37
<b>3</b>	<b>Product details</b>	<b>7</b>	8.4	Setting the heating control unit	37
3.1	Intended use	7	8.5	After commissioning	37
3.2	Explanation of model code	7	8.6	Appliances with hot water cylinder: setting the hot water temperature	38
3.3	Gas type	7	8.7	ZWB appliances - setting hot water temperature	39
3.4	Type plate	7	8.8	Summer mode (central heating off, DHW only)	39
3.5	Description of appliance	8	8.9	Frost protection	39
3.6	Accessories	8	8.10	Holiday mode	40
3.7	Dimensions and minimum clearances	9	8.11	Fault mode	40
3.8	Appliance layout	10	<b>9</b>	<b>Thermal disinfection on appliances with hot water cylinder</b>	<b>41</b>
3.9	Electrical wiring diagram	12	<b>10</b>	<b>Pump anti-seizing function</b>	<b>42</b>
3.10	Specification ZSB 30-2 ...	16	<b>11</b>	<b>Heatronic settings</b>	<b>43</b>
3.11	Specification ZWB 37-2 ...	17	11.1	General information	43
3.12	Condensate composition	18	11.2	Overview of service functions	44
<b>4</b>	<b>Regulations</b>	<b>19</b>	11.2.1	Service level 1	44
<b>5</b>	<b>Pre-Installation</b>	<b>20</b>	11.2.2	Service level 2	44
5.1	Water system and pipe work	20	11.3	Description of service functions	45
5.2	Condensate pipe work	22	11.3.1	Service level 1	45
5.2.1	Internal connections	22	11.3.2	Service level 2	49
<b>6</b>	<b>Installation</b>	<b>24</b>	<b>12</b>	<b>Converting the appliance to different gas types</b>	<b>50</b>
6.1	Important notes	24	12.1	Gas-type conversion	50
6.2	Checking the size of the expansion vessel	25	12.2	Setting the gas-air ratio (CO <sub>2</sub> or O <sub>2</sub> )	50
6.3	Siting the appliance	25	12.3	Checking the gas supply pressure	52
6.4	Pre-installing pipes	26	<b>13</b>	<b>Flue gas testing</b>	<b>53</b>
6.5	Fitting the appliance	28	13.1	Central heating boost button	53
6.6	Checking the connections	32	13.2	Checking flue system for leaks	53
<b>7</b>	<b>Electrical connections</b>	<b>33</b>	<b>14</b>	<b>Environmental protection</b>	<b>54</b>
7.1	General information	33			
7.2	Connecting accessories	33			
7.2.1	Connecting the heating controller or remote control units	34			
7.2.2	Connecting the DHW cylinder	34			
7.2.3	Connecting temperature limiter TB 1 from the flow of an underfloor heating system	34			

---

**15 Inspection/Serviceing . . . . . 55**

- 15.1 Checklist for inspection/serviceing  
(Inspection/Serviceing report) . . . . .56
- 15.2 Description of various serviceing  
operations . . . . .57
- 15.2.1 Retrieving last fault stored  
(service function 6.A) . . . . .57
- 15.2.2 Checking electrodes . . . . . 57
- 15.2.3 Strainer in cold water pipe (ZWB) . . . . 57
- 15.2.4 Plate type heat exchanger (ZWB) . . . . 58
- 15.2.5 Heat exchanger . . . . . 59
- 15.2.6 Burner . . . . . 61
- 15.2.7 Diaphragm in mixer unit . . . . . 62
- 15.2.8 Cleaning condensate trap . . . . . 62
- 15.2.9 Checking the expansion vessel  
(see also page 25) . . . . .62
- 15.2.10 Setting the heating system pressure . . 63
- 15.2.11 Checking electrical wiring . . . . . 63

---

**16 Displays . . . . . 64**

---

**17 Fault mode . . . . . 66**

- 17.1 Troubleshooting . . . . . 66
- 17.2 Faults that are shown on the display . . 67
- 17.3 Faults that are not shown  
on the display . . . . .70
- 17.4 Sensor values . . . . . 71
- 17.4.1 Outside temperature sensor  
(for weather-compensated controllers,  
accessory) . . . . .71
- 17.4.2 Flow and DHW sensors . . . . . 71
- 17.5 Settings for heating output with  
ZSB 30 ...23 . . . . .72
- 17.6 Settings for heating output with  
ZSB 30 ...31 . . . . .72
- 17.7 Settings for heating output with  
ZWB 37 ...23 . . . . .73
- 17.8 Settings for heating output with  
ZWB 37 ...31 . . . . .73

---

**18 Commissioning report for the appliance . . . . . 74**

---

**Index . . . . . 76**



# 1 Key to symbols and safety instructions

## 1.1 Explanation of symbols

### Warning symbols

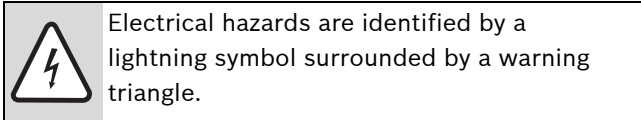
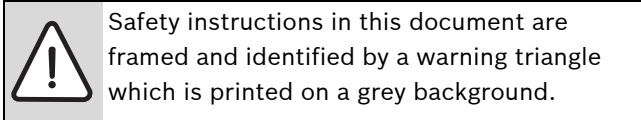

Signal words indicate the seriousness of the hazard in terms of the consequences of not following the safety instructions.

- **NOTICE** indicates possible damage to property or equipment, but where there is no risk of injury.
- **CAUTION** indicates possible injury.
- **WARNING** indicates possible severe injury.
- **DANGER** indicates possible risk to life.

### Important information

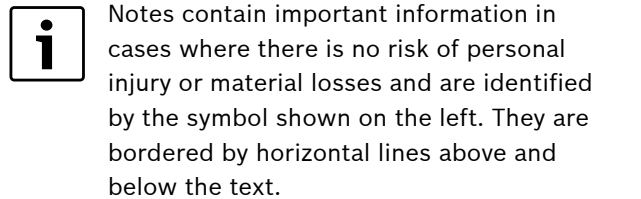

### Additional symbols

Symbol	Meaning
▶	a step in an action sequence
→	a reference to a related part in the document or to other related documents
•	a list entry
–	a list entry (second level)

Table 1

## 1.2 Safety instructions

### If you smell gas

- ▶ Turn off gas tap (→ page 35).
- ▶ Open windows and doors.
- ▶ Do not operate any electrical switches.
- ▶ Extinguish any naked flames.
- ▶ Leave the building and telephone your gas supply utility and authorised contractor **from an outside phone**.

### If you smell flue gas from the appliance

- ▶ Switch off the appliance (→ page 36).
- ▶ Open windows and doors.
- ▶ Inform your heating contractor.

### Explosive and easily flammable materials

Never use or store easily flammable materials (paper, thinners, paints, etc.) near the appliance.

### Combustion air/ambient air

To prevent corrosion, keep the supply of combustion/ambient air free of corrosive substances (e.g. halogenated hydrocarbons that contain chlorine or fluorine compounds).

### Thermal disinfection

#### ▶ Risk of scalding!

It is imperative to monitor operation at water temperatures over 60 °C (→ page 41).

## 2 Standard delivery

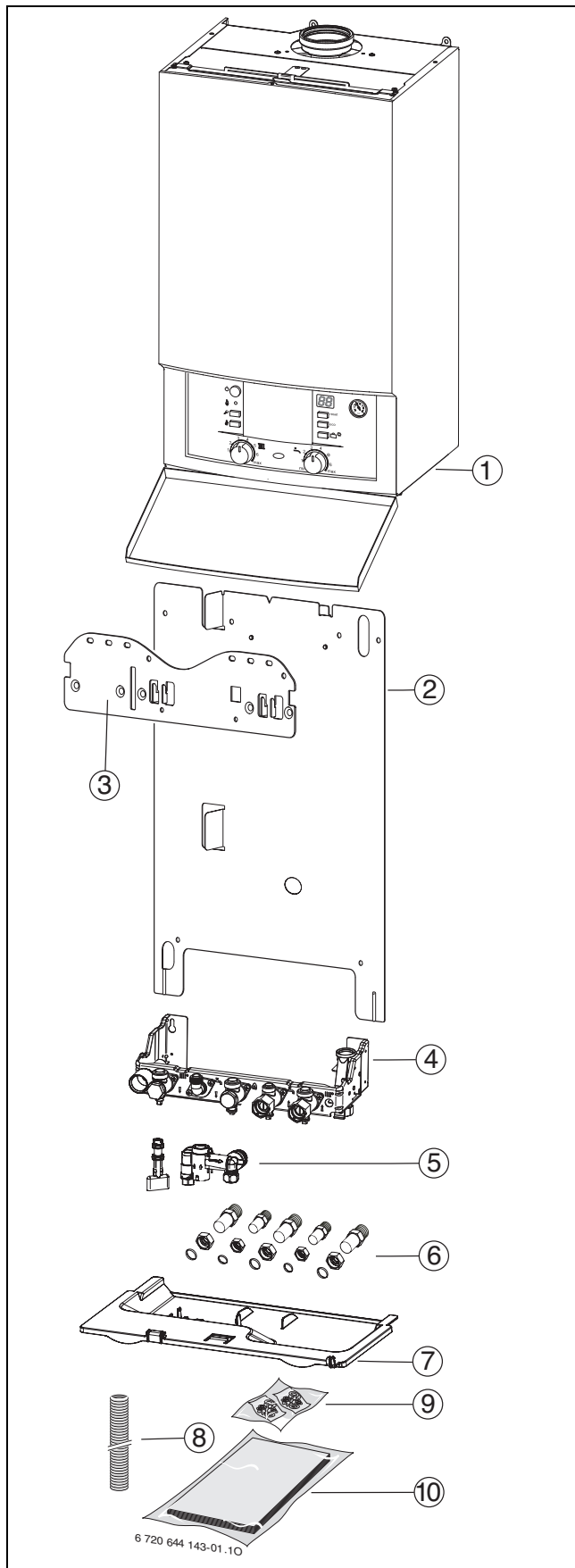

### Key:

- 1 Gas condensing boiler
- 2 Pre-plumbing jig
- 3 Mounting rail
- 4 Pre-plumbing jig for ZWB appliances  
(for ZSB appliances without cold and DHW water connections)
- 5 Filling loop with key (ZWB)
- 6 Adaptors for ZWB appliances  
(for appliances ZSB without adaptors for cold cold and DHW water connections)
- 7 Lower cover
- 8 Pressure relief valve hose (heating circuit)
- 9 Fixing kit
- 10 Set of printed documents for the appliance

Fig. 1

### 3 Product details

**ZSB** appliances are boilers for heating. They can be fitted with the diverter valve accessory to connect to an indirectly heated hot water cylinder.

**ZWB** appliances are combi boilers for central heating (CH) and domestic hot water (DHW) heating according to the instantaneous water heating principle.

#### 3.1 Intended use

The appliance may only be installed in a sealed unvented central heating system.

This appliance is intended for indoor use only. It is not to be used as a pool heater.

Using the appliance for any other purpose will be considered incorrect use. Bosch accepts no liability for any damage resulting from such use.

The commercial and industrial use of the appliance to generate process heat is not permitted.

#### 3.2 Explanation of model code

<b>ZSB 30-2</b>	A	23	S2414
<b>ZSB 30-2</b>	A	31	S2414
<b>ZWB 37-2</b>	A	23	S2414
<b>ZWB 37-2</b>	A	31	S2414

Table 2

<b>Z</b>	Central heating appliance
<b>S</b>	Cylinder connection
<b>W</b>	DHW heating
<b>B</b>	Condensing boiler technology
<b>30</b>	Output up to 30 kW
<b>37</b>	DHW output up to 37 kW
<b>-2</b>	Version
<b>A</b>	Fan-assisted appliance without draught hood
<b>23</b>	Natural gas H
	<b>Note:</b> Appliances can be converted to LPG.
<b>31</b>	LPG
<b>S2414</b>	Special number for Australia/New Zealand

#### 3.3 Gas type

The code number indicates the gas family according to AS 4552:

Code number	Wobbe index ( $W_S$ ) (15 °C)	Gas type
23	12.2 - 55.0 MJ/m <sup>3</sup>	NG
31	72.9 - 87.2 MJ/m <sup>3</sup>	LPG

Table 3

LPG type <sup>1)</sup>	Use
Commercial Propane	recommended
Commercial Butane	permitted
General Product	permitted
Universal LPG (U-LPG)	permitted

Table 4

1) according to NZS 5435

#### 3.4 Type plate

The type plate [47] can be found on the inside of the appliance at the bottom right (→ Fig. 3, page 10).

It contains details of the output of the appliance, the order number, the approval data and the date of manufacture in encoded form.

### 3.5 Description of appliance

- Wall mounted boiler; installation independent of chimney location or room size.
- **Intelligent heating circuit pump control when connected to an weather-dependent heating controller**
- **Heatronic 3 controls with 2-wire BUS**
- **ZWB appliances can be supplied with water preheated by solar energy, → page 24**
- **Optimised electronic heating circuit pump with:**
  - 2 proportional pressure curves
  - 3 constant pressure curves
  - 6 stages can be selected
  - Run-dry protection and anti-seizing function
- Connecting lead with mains plug
- Display
- Automatic ignition
- Modulating output control
- Fully featured safety system provided by Heatronic module with flame failure detection and solenoid valves to EN 298
- No minimum water circulation rate required
- Suitable for underfloor heating
- Connection option for concentric pipe for flue gas/ combustion air Ø 80/125 mm, Ø 60/100 mm
- Variable speed fan
- Premix burner
- Temperature sensor and temperature control for central heating
- Temperature sensor in flow
- Safety temperature limiter in 24 V electrical circuit
- Pressure relief valve, pressure gauge, expansion vessel
- Optional for DHW cylinder temperature sensor (NTC)
- Flue gas temperature limiter
- DHW priority
- Plate type heat exchanger (ZWB)
- Motorised three-way valve (ZWB)
- Filling loop (ZWB)
- Pre-plumbing jig

### 3.6 Accessories



Below is a list of typical accessories for this appliance. You can find comprehensive details of all available accessories in our catalogue.

- Flue kits
- Weather-compensated controller, e.g. FW 100
- Room temperature controller, e.g. FR 10, FR 110
- Digital time switch, e.g. DT 10 RF, DT 20 RF
- Cylinder temperature sensor SF 2 for third party cylinders
- Optional Diverter Valve Kit for DHW cylinder connection including cylinder temperature sensor (ZSB only).

### 3.7 Dimensions and minimum clearances

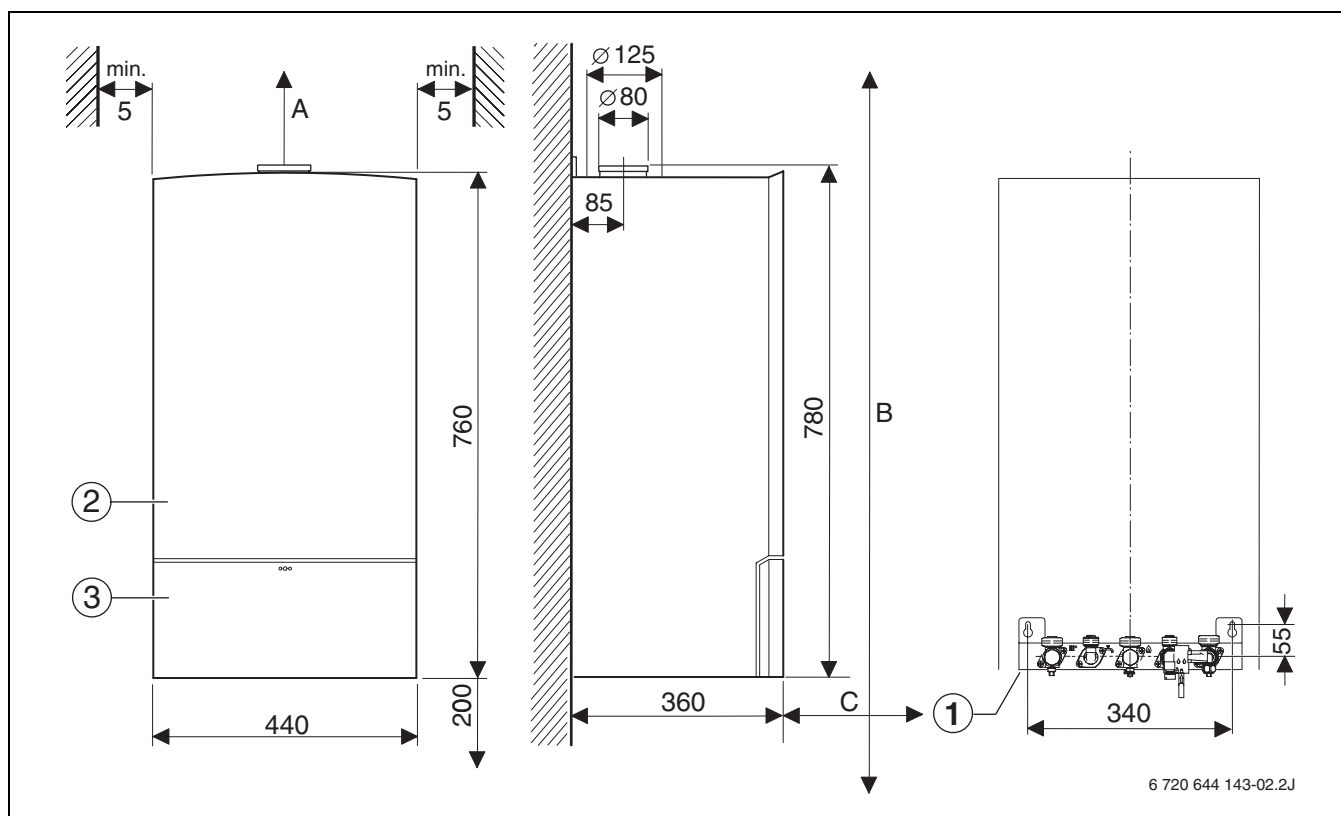

Fig. 2

- 1** Pre-plumbing jig
- 2** Casing
- 3** Fascia
- A** Additional 30 mm above elbow
- B** Using 100 mm flue kit: 1112 mm /  
120 mm flue kit: 1152 mm
- C** 20 mm to reversible door /  
600 mm front clearance for service

### 3.8 Appliance layout

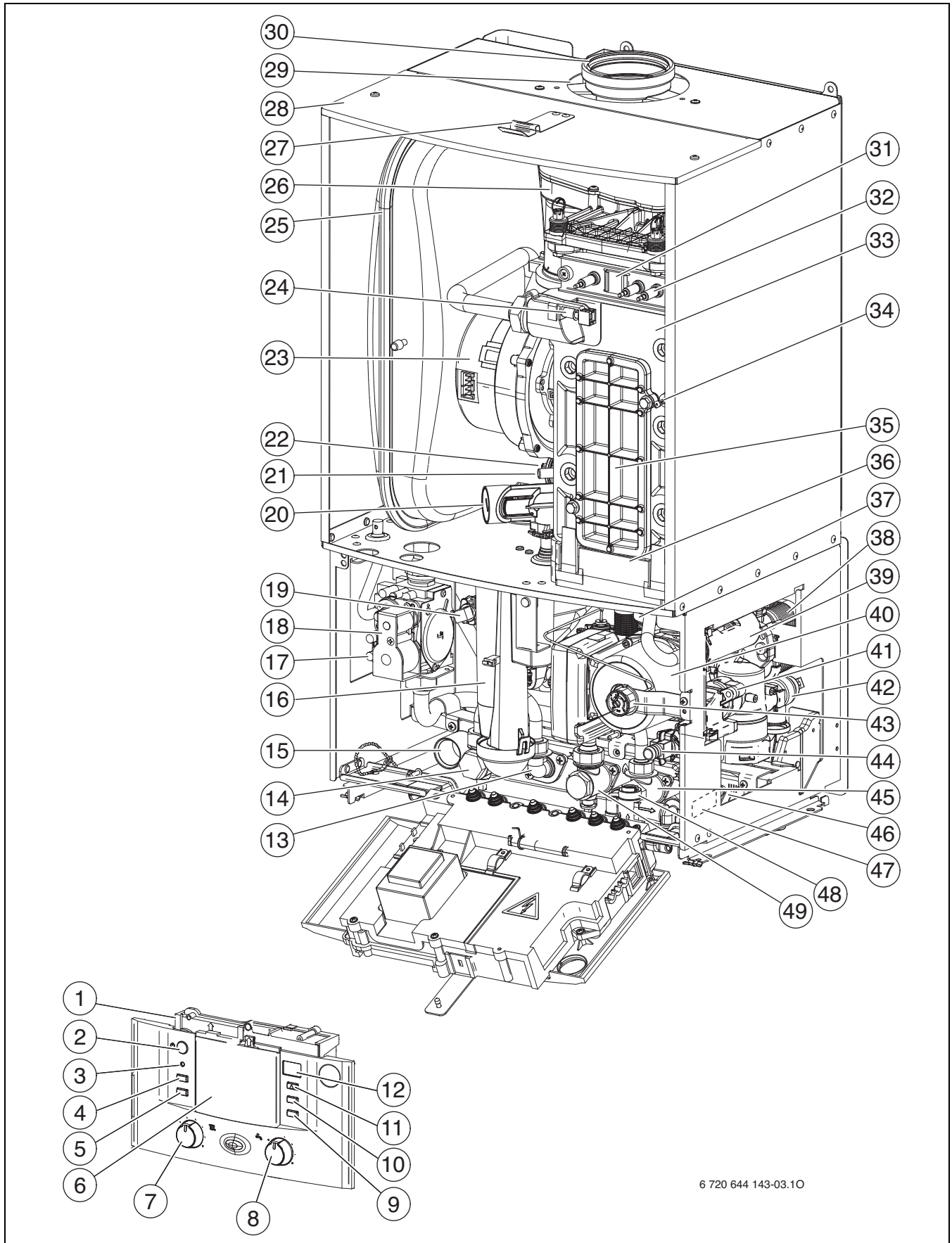

Fig. 3

**Key to figure 3:**

- 1** Heatronic 3
- 2** Main switch
- 3** Burner ON indicator
- 4** Service button
- 5** Central heating boost button
- 6** Here, a weather-compensated control unit or a time switch (accessories) can be plugged in
- 7** CH Flow temperature control
- 8** DHW temperature control
- 9** Holiday button
- 10** eco button
- 11** reset button
- 12** Display
- 13** DHW (ZWB)
- 14** CH flow
- 15** Adaptor for condensate hose
- 16** Condensate syphon
- 17** Gas supply pressure test port
- 18** Gas valve
- 19** DHW temperature sensor
- 20** Adjustable gas throttle
- 21** Test point for control pressure
- 22** Flue gas temperature limiter
- 23** Fan
- 24** Flow temperature sensor
- 25** Expansion vessel
- 26** Mixer unit
- 27** Bracket
- 28** Removable cover
- 29** Combustion air inlet
- 30** Flue pipe
- 31** Sight glass
- 32** Set of electrodes
- 33** Heat exchanger
- 34** Temperature limiter for heat exchanger
- 35** Access port for cleaning heat exchanger
- 36** Condensate tray
- 37** Automatic air vent valve
- 38** Plate-type heat exchanger (ZWB)
- 39** Turbine (ZWB)
- 40** Heating circuit pump
- 41** 3-way diverter valve
- 42** Pressure relief valve (heating circuit)
- 43** Pressure gauge
- 44** Drain tap
- 45** Cold water inlet
- 46** Heating return
- 47** Type plate
- 48** Filling loop (ZWB)
- 49** Gas connection

### 3.9 Electrical wiring diagram

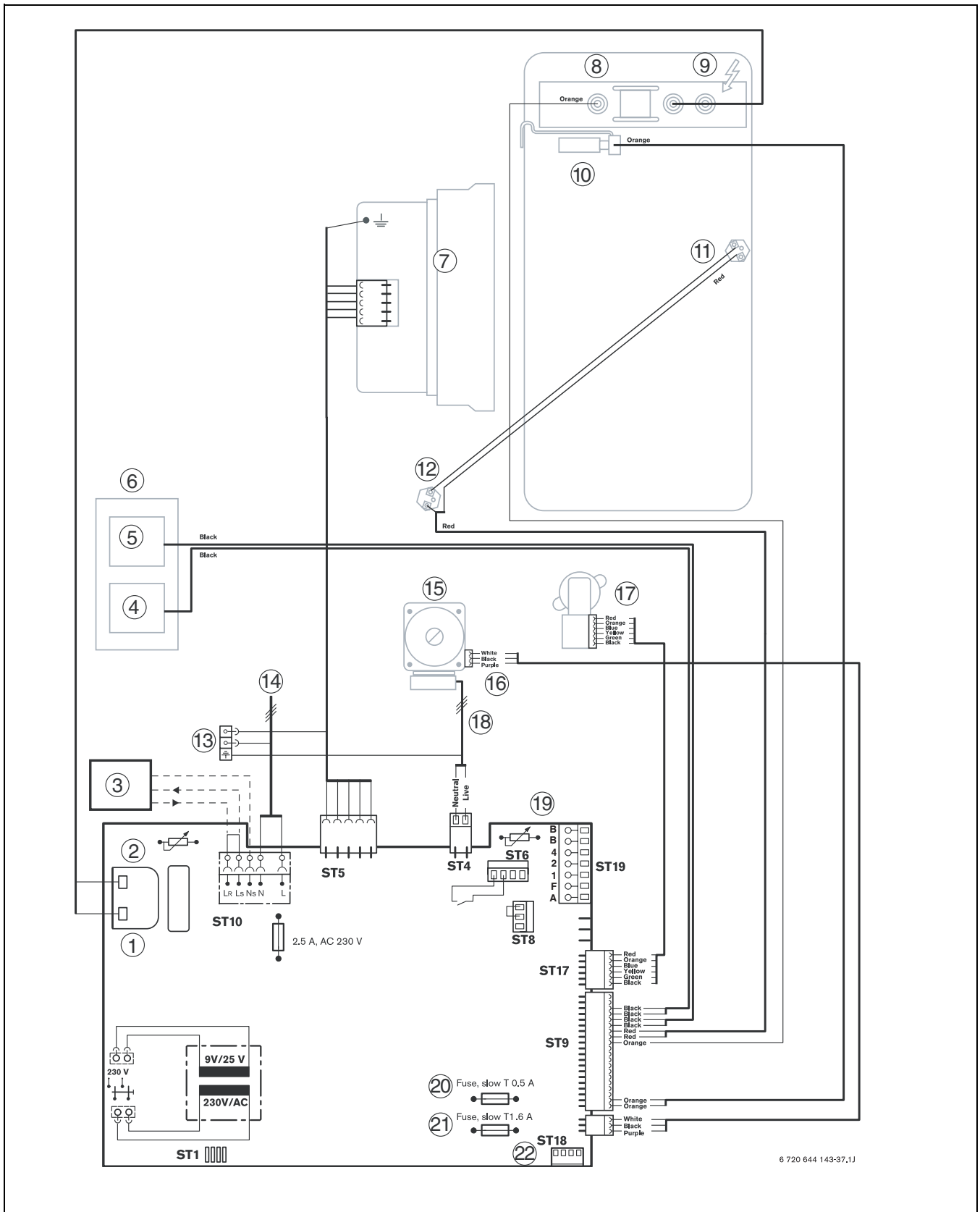
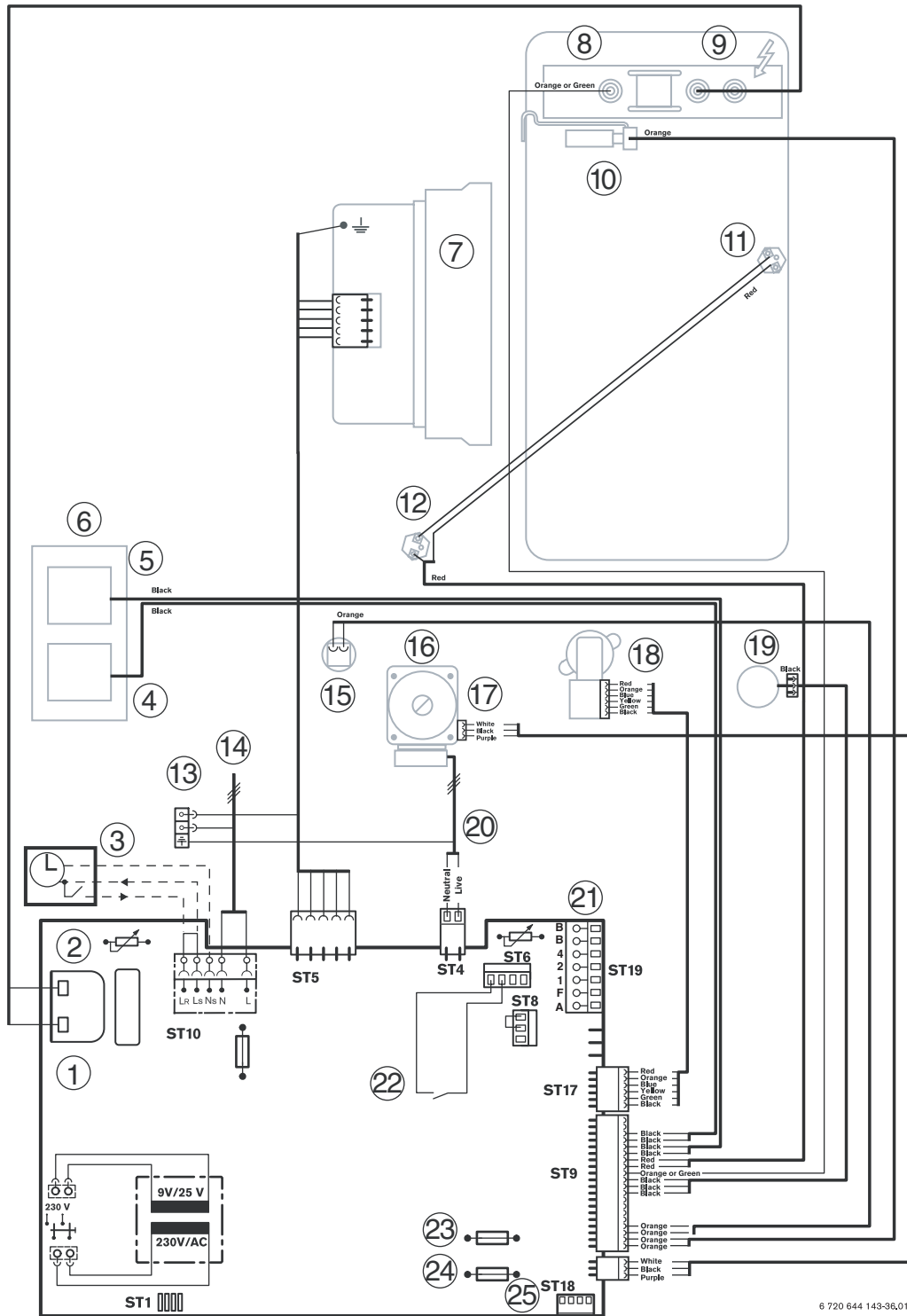

Fig. 4 ZSB 30-2

- 1** Spark transformer
- 2** CH temperature control
- 3** Wiring centre
- 4** Safety solenoid
- 5** Safety solenoid
- 6** Gas valve
- 7** Fan
- 8** Flame sense electrode
- 9** Spark electrodes
- 10** Flow NTC
- 11** Heat exchanger overheat stat.
- 12** Flue overheat stat.
- 13** Earth
- 14** Mains supply
- 15** Pump
- 16** Pump control
- 17** Diverter valve (optional)
- 18** Pump supply
- 19** DHW temperature control
- 20** Fluse slow T 0.5 A
- 21** Fluse slow T 1.6 A
- 21** Code plug



6 720 644 143-36,01J

Fig. 5 ZWB 37-2

- 1** Spark transformer
- 2** CH temperature control
- 3** 230 V room stat/programmer
- 4** Safety solenoid
- 5** Safety solenoid
- 6** Gas valve
- 7** Fan
- 8** Flame sense electrode
- 9** Spark electrodes
- 10** Flow NTC
- 11** Heat exchanger overheat stat.
- 12** Flue overheat stat.
- 13** Earth
- 14** Mains supply
- 15** DHW sensor
- 16** Pump
- 17** Pump control
- 18** Diverter valve
- 19** Flow turbine
- 20** Pump supply
- 21** DHW temperature control
- 22** External frost stat (optional)
- 23** Fuse slow T 0.5 A
- 24** Fuse slow T 1.6 A
- 25** Code plug

### 3.10 Specification ZSB 30-2 ...

	Unit	ZSB 30-2 ...		
		Natural gas	Propane	Butane
Max. heat output ( $P_{max}$ ) 40/30 °C	kW	32.1	32.1	36.6
Max. heat output ( $P_{max}$ ) 50/30 °C	kW	31.8	31.8	36.3
Max. heat output ( $P_{max}$ ) 80/60 °C	kW	30.0	30.0	34.2
Max. gas consumption ( $Q_{max}$ ), central heating	MJ/h	123.4	123.4	140.5
Min. heat output ( $P_{min}$ ) 40/30 °C	kW	8.6	12.4	14.2
Min. heat output ( $P_{min}$ ) 50/30 °C	kW	8.6	12.3	14.0
Min. heat output ( $P_{min}$ ) 80/60 °C	kW	7.7	11.0	12.6
Min. gas consumption ( $Q_{min}$ ), central heating	MJ/h	31.9	11.5	52.3
Max. heat output ( $P_{nW}$ ), DHW	kW	30.9	45.9	35.2
Max. gas consumption ( $Q_{nW}$ ), DHW	MJ/h	123.4	123.4	140.5
<b>Gas supply rate</b>				
Natural gas (gross heating value 37.8 MJ/m <sup>3</sup> )	m <sup>3</sup> /h	3.2	-	-
Butane/propane (gross heating value 50 MJ/kg)	kg/h	-	2.4	2.8
<b>Permissible gas supply pressure</b>				
NG	kPa	1.1 - 3.0	-	-
LPG	kPa	-	2.75	2.75
<b>Expansion vessel</b>				
Pre-charge pressure	kPa	75	75	75
Total capacity	l	10	10	10
<b>Calculation values for calculating cross-section to EN 13384</b>				
Flue gas mass flow rate, max./min. rated	g/s	13.6/3.7	12.8/5.2	12.8/5.2
Flue gas temperature 80/60 °C max./min. rated	°C	76/58	76/58	76/58
Flue gas temperature 40/30 °C max./min. rated	°C	55/33	55/33	55/33
Residual pump head	Pa	80	80	80
CO <sub>2</sub> at max. rated output	%	9.6	10.8	12.2
CO <sub>2</sub> min. rated output	%	9.0	10.2	11.5
Flue gas rating group to G 636/G 635		G <sub>61</sub> /G <sub>62</sub>	G <sub>61</sub> /G <sub>62</sub>	G <sub>61</sub> /G <sub>62</sub>
NO <sub>x</sub> class		5	5	5
<b>Condensate</b>				
Max. condensate quantity ( $t_R = 30$ °C)	l/h	2.7	2.7	2.7
pH level, approx.		4.8	4.8	4.8
<b>General data</b>				
Power supply voltage	AC ... V	220 - 240	220 - 240	220 - 240
Frequency	Hz	50	50	50
Max. power consumption (central heating mode)	W	150	150	150
EMC limit class	-	B	B	B
Noise output level	≤ dB(A)	43	43	43
Appliance enclosure rating	IP	X4D	X4D	X4D
Max. flow temperature	°C	Approx. 90	Approx. 90	Approx. 90
Max. permissible operating pressure ( $P_{MS}$ ) heating	kPa	300	300	300
Permissible ambient temperature	°C	0 - 50	0 - 50	0 - 50
Nominal capacity of appliance heating	l	3.5	3.5	3.5
Weight (excluding packaging)	kg	46.5	46.5	46.5
Dimensions, W x H x D	mm	440 x 760 x 360	440 x 760 x 360	440 x 760 x 360

Table 5

### 3.11 Specification ZWB 37-2 ...

	Unit	ZWB 37-2 ...		
		Natural gas	Propane	Butane
Max. heat output ( $P_{max}$ ) 40/30 °C	kW	32.1	32.1	36.6
Max. heat output ( $P_{max}$ ) 50/30 °C	kW	31.8	31.8	36.3
Max. heat output ( $P_{max}$ ) 80/60 °C	kW	30.0	30.0	34.2
Max. gas consumption ( $Q_{max}$ ), central heating	MJ/h	123.4	123.4	140.5
Min. heat output ( $P_{min}$ ) 40/30 °C	kW	10.6	15.7	17.9
Min. heat output ( $P_{min}$ ) 50/30 °C	kW	10.5	15.5	17.7
Min. heat output ( $P_{min}$ ) 80/60 °C	kW	9.4	13.9	15.9
Min. gas consumption ( $Q_{min}$ ), central heating	MJ/h	39.1	57.9	65.9
Max. heat output ( $P_{nW}$ ), DHW	kW	37.0	37.0	42.2
Max. gas consumption ( $Q_{nW}$ ), DHW	MJ/h	147.7	147.7	168.5
<b>Gas supply rate</b>				
Natural gas H (gross heating value 37.8 MJ/m <sup>3</sup> )	m <sup>3</sup> /h	3.9	-	-
Butane/propane (gross heating value 50 MJ/kg)	kg/h	-	2.9	3.4
<b>Permissible gas supply pressure</b>				
NG	kPa	1.1 - 3.0	-	-
LPG	kPa	-	2.75	2.75
<b>Expansion vessel</b>				
Pre-charge pressure	kPa	75	75	75
Total capacity	l	10	10	10
<b>DHW</b>				
Max. DHW flow rate	l/min	13.0	13.0	13.0
Outlet temperature range	°C	40 - 60	40 - 60	40 - 60
Max. cold water inlet temperature	°C	60	60	60
Max. permissible water supply pressure	kPa	1000	1000	1000
Min. inlet pressure	kPa	300	300	300
Specific flow rate acc. to EN 625 (D)	l/min	16.9	16.9	16.9
<b>Calculation values for calculating cross-section to EN 13384</b>				
Flue gas mass flow rate, max./min. rated	g/s	16.2/4.5	15.3/6.5	15.3/6.5
Flue gas temperature 80/60 °C max./min. rated	°C	83/58	83/58	83/58
Flue gas temperature 40/30 °C max./min. rated	°C	60/35	60/35	60/35
Residual pump head	Pa	80	80	80
CO <sub>2</sub> at max. rated output	%	9.7	10.8	12.2
CO <sub>2</sub> min. rated output	%	9.1	10.2	11.5
Flue gas rating group to G 636/G 635		G <sub>61</sub> /G <sub>62</sub>	G <sub>61</sub> /G <sub>62</sub>	G <sub>61</sub> /G <sub>62</sub>
NO <sub>x</sub> class		5	5	5
<b>Condensate</b>				
Max. condensate quantity ( $t_R = 30$ °C)	l/h	2.7	2.7	2.7
pH level, approx.		4.8	4.8	4.8

Table 6

	Unit	ZWB 37-2 ...		
		Natural gas	Propane	Butane
<b>General data</b>				
Power supply voltage	AC ... V	220 - 240	220 - 240	220 - 240
Frequency	Hz	50	50	50
Max. power consumption (central heating mode)	W	160	160	160
EMC limit class	-	B	B	B
Sound pressure level (in heating mode)	≤ dB(A)	45	45	45
Appliance enclosure rating	IP	X4D	X4D	X4D
Max. flow temperature	°C	Approx. 90	Approx. 90	Approx. 90
Max. permissible operating pressure (P <sub>MS</sub> ) heating	kPa	300	300	300
Permissible ambient temperature	°C	0 - 50	0 - 50	0 - 50
Nominal capacity of appliance heating	l	3.75	3.75	3.75
Weight (excluding packaging)	kg	48.5	48.5	48.5
Dimensions, W x H x D	mm	440 x 760 x 360	440 x 760 x 360	440 x 760 x 360

Table 6

### 3.12 Condensate composition

Material	Value [mg/l]
Ammonium	1.2
Lead	≤ 0.01
Cadmium	≤ 0.001
Chrome	≤ 0.005
Halogenated hydrocarbons	≤ 0.002
Hydrocarbons	0.015
Copper	0.028
Nickel	0.1
Mercury	≤ 0.0001
Sulphate	1
Zinc	≤ 0.015
Tin	≤ 0.01
Vanadium	≤ 0.001
pH value	4.8

Table 7

## 4 Regulations

Any local by-laws and regulations pertaining to installation and use of gas-heated appliances must be observed.

This appliance must be installed in accordance with the manufacturers installation instructions, AS 5601, NZ 5261 and all Local Building & Gas fitting regulations. It is recommended that for sanitary fixtures used for the purpose of personal hygiene, a temperature limiting device be fitted (such as a tempering valve) as per AS3498.

This appliance must not be installed in a bedroom, bathroom, toilet, or combined living/sleeping room as per AS 5601 5.12.5.2

Failure to install this appliance in accordance with these installation instructions will void the warranty.

Where no specific instruction is given, reference should be made to the following standards:

- AS 5602/NZ 5261 Gas Installations,
- AS 1596 LPG storage and handling,
- AS 4552 Gas fired water heaters for hot water supply and/or central heating,
- AS/NZS 3000 Electrical Installations,
- AS1697 Installation and maintenance of steel pipe systems for gas,
- AS 4032 Water supply - valves for the control of hot water supply temperatures,
- AS 3498 Authorization requirements for plumbing products - water heaters and hot-water storage tanks.
- AS 1910 Water supply - float control valves for use in hot and cold water,
- AS 3500 National plumbing and drainage code.

## 5 Pre-Installation

### 5.1 Water system and pipe work

#### Plastic pipe work:

- Any plastic pipe work must have a polymeric barrier with 600 mm (minimum) length of copper pipe connected to the boiler.
- Plastic pipe work used for underfloor heating must be correctly controlled with a thermostatic blending valve limiting the temperature of the circuits to approximately 50 °C.

#### Primary systems connections/valves:

- All system connections, taps and mixing valves must be capable of sustaining a pressure up to 3 bar (300 kPa).
- Bosch recommends that thermostatic radiator valves (TRV's) be used on all radiators within the sleeping accommodation but not the radiator where the room thermostat is sited. This must be fitted with lock-shield valves and left open.
- A drain point is required at the lowest part of the system.
- An air vent is required at all the high points in the system.



The boiler is equipped with an automatic internal by-pass.

#### Sealed primary system:



**NOTE:** Artificially softened water must not be used to fill the CH system.

- The CH sealed system must be filled using an approved filling loop or comply with figure 6 for system fill.
- Do not use galvanised pipes or radiators.**

#### System fill

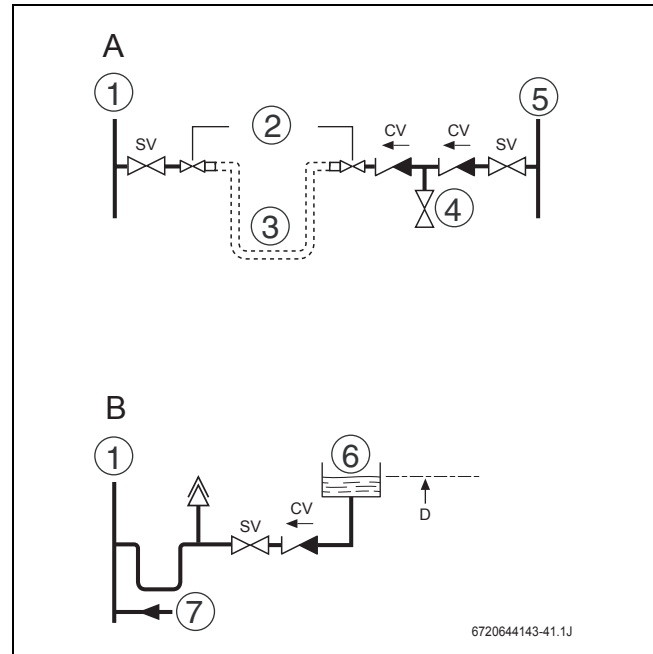

Fig. 6

- A** System fill
- AA** Auto air vent
- B** System make up
- CV** Check valve
- D** 1000 mm (39 in.) above the highest point of the system
- SV** Stop valve
- 1** Heating return
- 2** Hose union
- 3** Temporary hose
- 4** Test point
- 5** Mains supply
- 6** Make-up vessel
- 7** Fill point

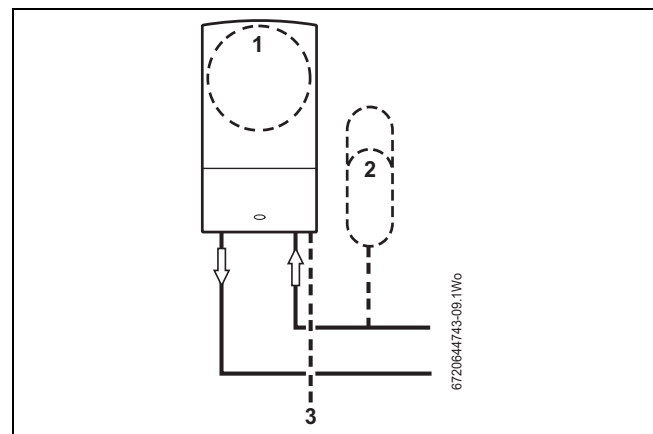

Fig. 7 Additional expansion vessel

- 1** Boiler expansion vessel - CH
- 2** Extra expansion vessel - CH return
- 3** Pressure relief discharge-

**S and Y plan systems:**

**NOTE:** The boiler is fitted with its own internal bypass.

**NOTE:**

- ▶ A drain point should be fitted at the lowest part of the heating circuit and beneath the boiler.

**Optional diverter valve**

This boiler is designed to operate on a sealed system only and will require a second return pipe from the water cylinder to the wall mounting frame.

**Hot water supplied to sanitary fixtures**

In accordance with AS 3498 a temperature control device such as a tempering valve must be fitted when hot water is supplied to sanitary fixtures used primarily for the purposes of personal hygiene.

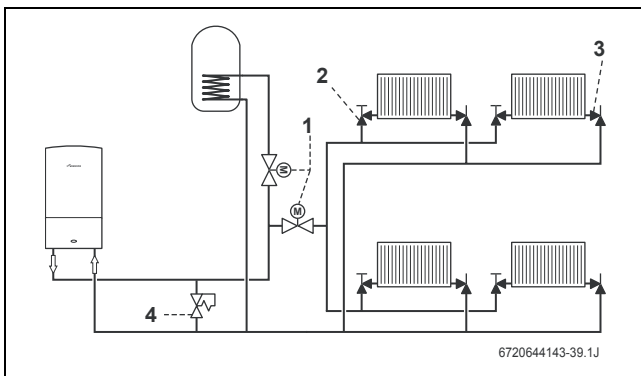

Fig. 8 S plan layout

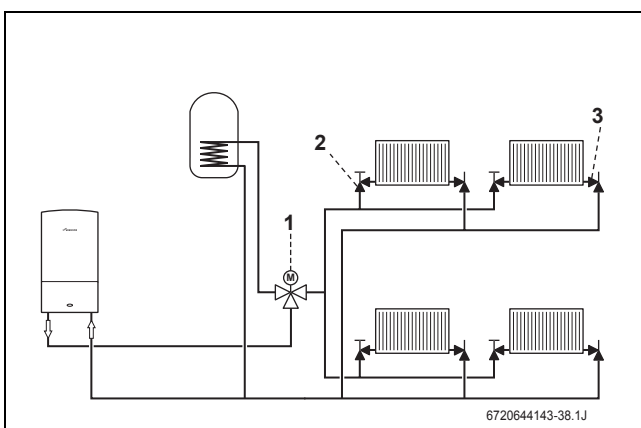

Fig. 9 Y plan layout with external diverter valve

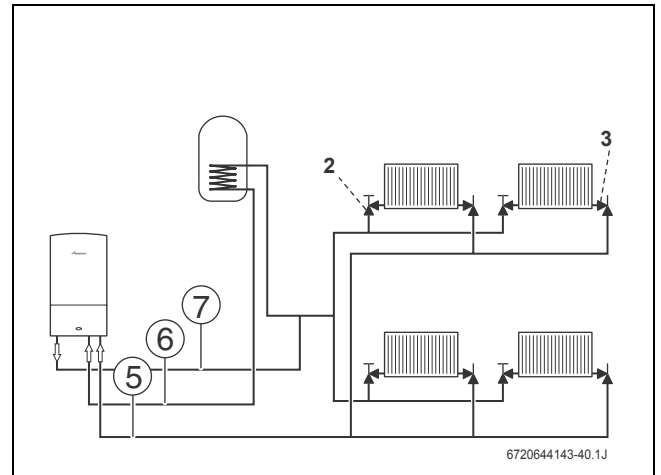

Fig. 10 System layout with optional internal diverter valve (not supplied with boiler)

**Legend to Fig. 8 to Fig. 10:**

- 1 Diverter valve
- 2 Radiator valve (flow)
- 3 Lock shield valve (return)
- 4 Bypass
- 5 Boiler flow
- 6 Cylinder return
- 7 Heating return

## 5.2 Condensate pipe work



### NOTE:

- ▶ Where a new or replacement boiler is being installed and freezing conditions are possible, access to an internal drain “gravity discharge” point should be one of the factors considered in determining boiler location.
- ▶ The condensate pipe must be a minimum of 40 mm Ø plastic pipe.
- ▶ The condensate pipe work must fall at least 50 mm per metre towards the outlet and should take the shortest practicable route.
- ▶ Ensure that there are no blockages in the pipe run.

### Key to condensate illustrations

1	Condensate discharge
2	Air gap (20mm)
3	Tundish
4	Self sealing device
5	Dishwasher connection
6	Vent stack

Table 8

### 5.2.1 Internal connections

Where there is the possibility of freezing conditions and in order to minimise the freezing risk during prolonged cold spells, the following methods of installing condensate drainage pipe should be adopted, in order of priority.

Wherever possible, the condensate drainage pipe should be routed and terminated so that the condensate drains away from the boiler under gravity to a suitable internal soil and vent stack. A suitable permanent connection to the foul waste pipe should be used.

A self sealing device should be incorporated in the drainage path, if possible, in an upright position. A tundish should be used as a suitable air gap just before the self sealing device. The self sealing device can be used on a gradient as long as it preceded by a vertically mounted tundish.

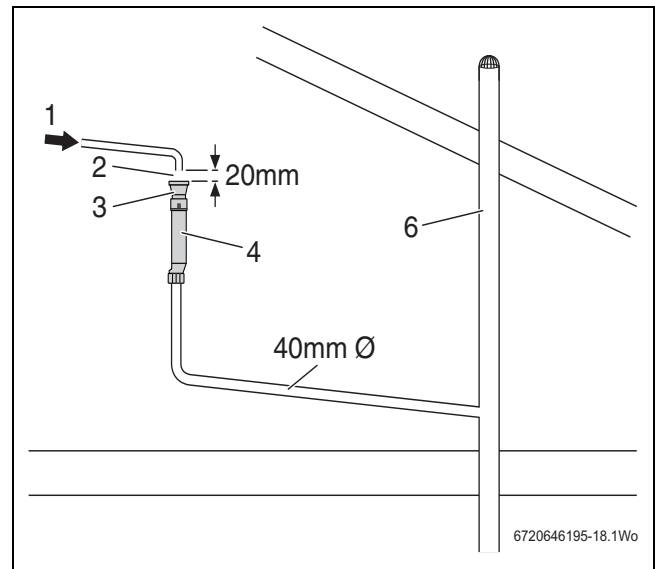

Fig. 11 Disposal to soil vent stack - vertical position

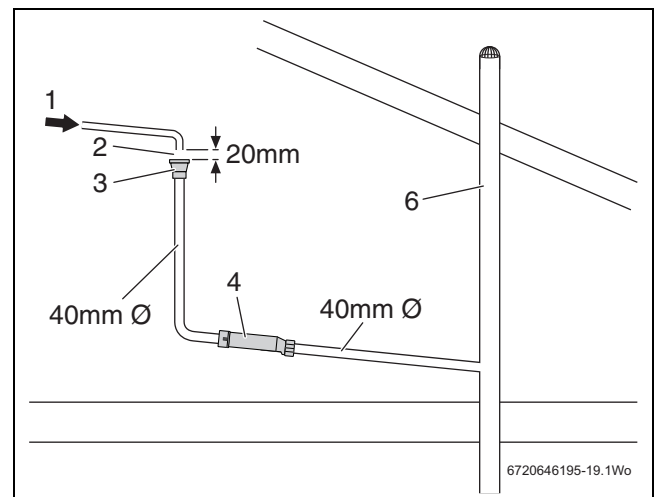

Fig. 12 Disposal to soil vent stack - on gradient

Alternatively if the first option is not possible an internal kitchen or bathroom waste pipe can be used.

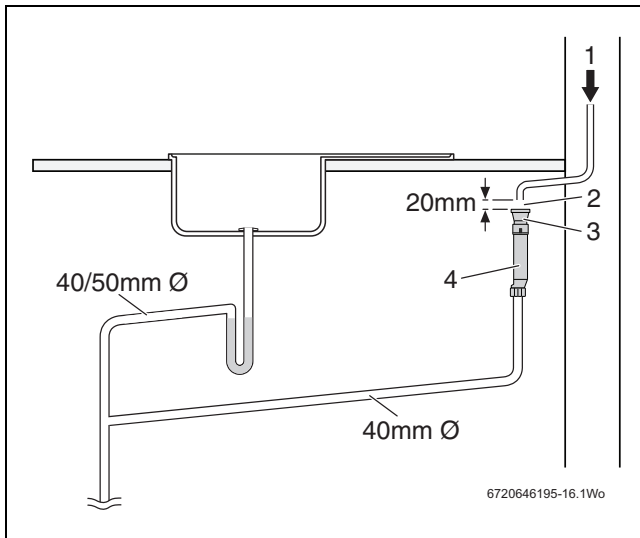

Fig. 13 Disposal to a waste pipe

A washing machine waste pipe or bifurcated pipe etc. can also be used.

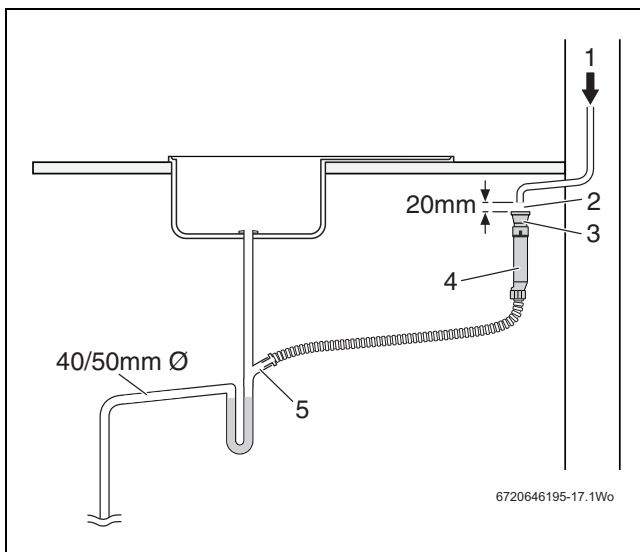

Fig. 14 Bifurcated pipe disposal

## 6 Installation



**DANGER:** Risk of explosion!

- ▶ Isolate the gas supply before working on gas-carrying components.
- ▶ Check for leaks before working on gas-carrying components.



Installation, power connection, connection on the gas and flue gas side and commissioning must only be carried out by a contractor approved for such work by the local gas or power supply utility.

### 6.1 Important notes

- ▶ Prior to installation, obtain the approval of the gas supply utility.

#### Supply of water preheated by solar energy (only ZWB)



**WARNING:** Risk of scalding!

Hot water can lead to severe scalding.



**NOTE:** Excessive temperatures through water preheated by solar energy can damage the equipment.

- ▶ Install a solar transfer valve upstream of the appliance and set to 60 °C.
- ▶ To prevent excessive lime scale being deposited, set the thermostatic mixer to 55 °C when encountering a total hardness of 15 °dH or higher.

#### Heating system water

Unsuitable fill and top-up water in the heating system can result in the heat exchanger scaling up and failing prematurely.

Hardness range	Water treatment
soft ( $\leq 8.4$ °dH)	not required
medium (8.4 - 14 °dH)	recommended
hard ( $\geq 14$ °dH)	required

Table 9



**CAUTION:** The type of fluid used in the combination boiler heating circuit is to be of a non-toxic type.

#### Anti-freeze

The following anti-freeze fluids are permitted:

Product	Concentration
Varidos FSK	22 - 55 %
Alphi - 11	see manufacturer's instructions
Glythermin NF	20 - 62 %

Table 10

#### Corrosion inhibitor

The following corrosion inhibitors are permitted:

Designation	Concentration
Fernox	see supplier information
Sentinel	see supplier information

Table 11

#### Open vented heating systems

- ▶ Open vented heating systems must be converted to sealed systems.

#### Gravity fed heating systems

- ▶ Connect the appliance to the existing pipework via a low loss header with a dirt separator.

#### Underfloor heating systems

- ▶ The appliance is suitable for underfloor heating systems; observe permissible flow temperatures.

#### If a room thermostat is used

- ▶ Do not fit a thermostatic radiator valve to the radiator in the primary room.

To increase efficiency of the system, thermostatic radiator valves should be used on all other radiators.

#### Sealants

In our experience, adding sealants to the heating water may result in problems (deposits in the heat exchanger). We therefore advise against using them.

#### Water circulation noises

To prevent water circulation noises:

- ▶ Fit an overflow valve, or, with two-pipe heating systems, a 3-way valve to the radiator furthest from the boiler.

### **Mono-lever taps and thermostatic mixer taps**

All types of mono-lever taps and thermostatic mixer taps can be used.

#### **LPG**

To protect the appliance against excessive pressure:

- ▶ Fit a pressure regulator with a safety valve.

---

## **6.2 Checking the size of the expansion vessel**

The integrated expansion vessel is pre-charged to 0.75 bar (75 kPa).

Where the system volume is more than 100 litres or exceeds 2.65 bar (265 kPa) at maximum heating temperature, an additional expansion vessel must be fitted as close as possible to the appliance in the central heating return.

All expansion vessels must have the same pressure.

---

## **6.3 Siting the appliance**

### **Regulations concerning the installation site**

- ▶ Observe relevant national regulations.
- ▶ Consult the flue kit installation instructions for details of minimum clearances required for flue gas routing.
- ▶ Do not install the appliance outside.

If the appliance is fitted into a cupboard or a compartment is built around the appliance after installation, then the compartment must be built from or lined with a non-combustible material.

### **Combustion air**

In order to prevent corrosion, the combustion air must not contain any corrosive substances.

Substances classed as corrosion-promoting include halogenated hydrocarbons which contain chlorine and fluorine compounds. They may be found in solvents, paints, adhesives, aerosol propellants and household cleaners, for example..

### **Surface temperature**

The maximum surface temperature of the appliance is below 85 °C. Therefore no special safety measures are required to protect flammable materials and fitted furniture.

### **Ventilation**

This is a room sealed appliance and does not require any air for combustion from inside the property.

There is no need for ventilation openings to be provided in the compartment because of the low heat loss from the appliance casing, if the clearances shown are maintained (→ Section 3.7, Page 9)

## 6.4 Pre-installing pipes

- ▶ Hook mounting rail into the mounting plate.
- ▶ Position mounting plate against the wall, observing minimum side clearances of 100 mm (→ page 9).
- ▶ Mark out four holes:
  - One of holes A
  - One of holes B
  - Hole C
  - Hole D
- ▶ Drill  $\varnothing$  10 mm holes.

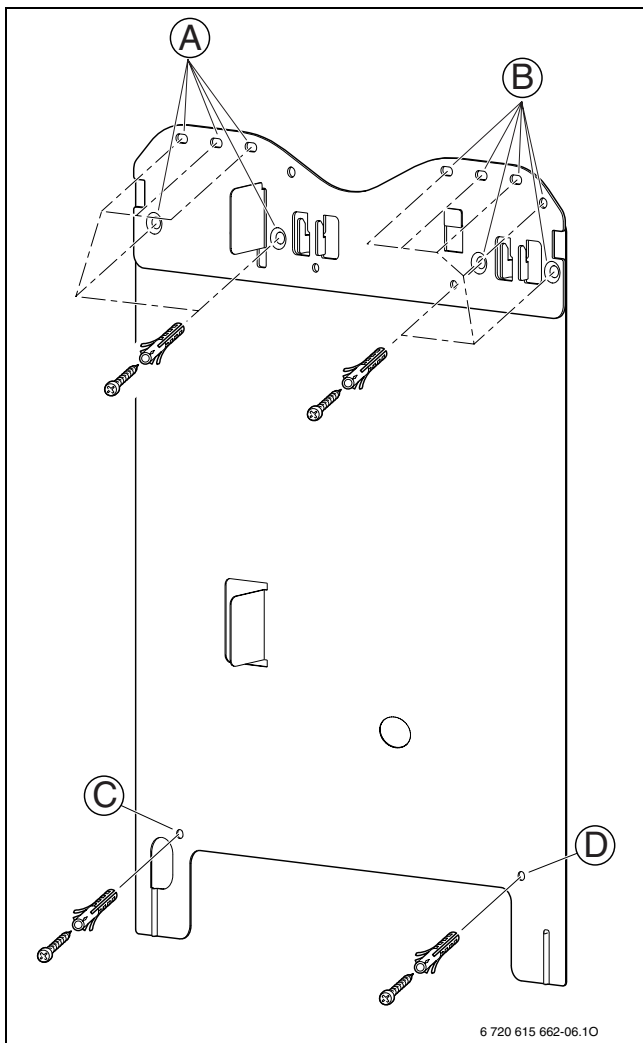

Fig. 15 Mounting plate

- ▶ Secure mounting plate with mounting rail to the wall using the screws provided; do not tighten the two lower screws.
- ▶ Hook in pre-plumbing jig and tighten screws.

## Gas and water connections

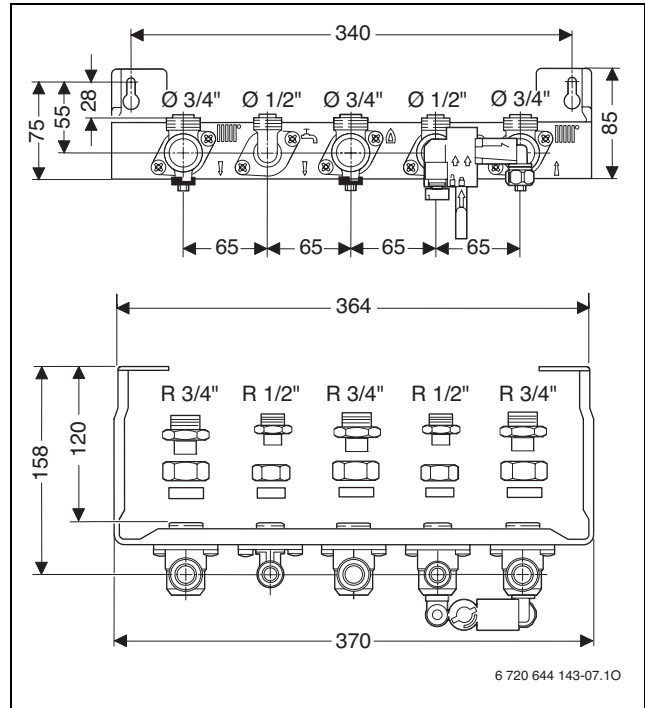

Fig. 16 Pipe connections

Additional adaptors are provided in the fittings kit for easy connection.



It is very important to ensure that pipes are not secured in such a way that the fittings come under strain.

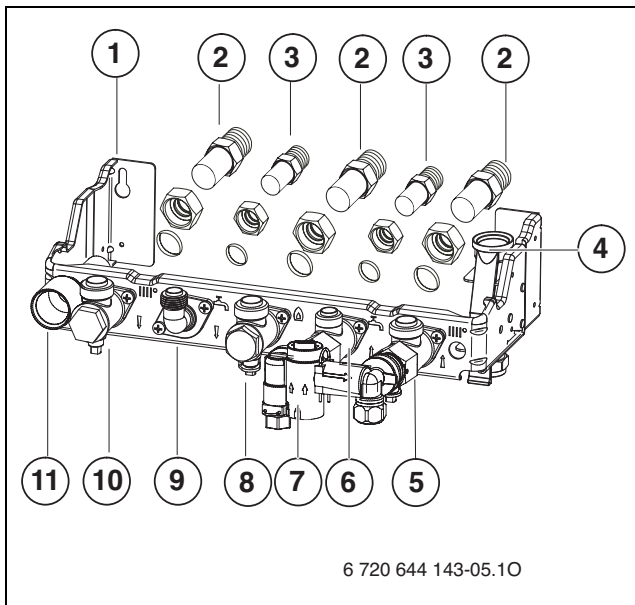

Fig. 17 Pipe connections

- 1 Pre-plumbing jig
- 2 Adaptor BSP 3/4" tapered thread with union nut G3/4" and olive to adapt to local piping connections
- 3 Adaptor BSP 1/2" tapered thread with union nut G1/2" and olive (ZWB) to adapt to local piping connections
- 4 Pressure relief valve drain
- 5 Heating return
- 6 ZWB: Cold water connection  
ZSB: Cylinder return
- 7 Filling loop (ZWB)
- 8 Gas connection
- 9 ZWB: DHW connection  
ZSB: Cylinder flow
- 10 Heating flow
- 11 Condensate connector

- ▶ The pipe for gas supply must be larger than 18 mm in diameter.
- ▶ For filling and draining the system, fit drain & fill valves at the lowest point of the system.

### Pipework behind the appliance

The pipes can be routed behind the appliance in the guide on the mounting plate (→ Fig. 18).

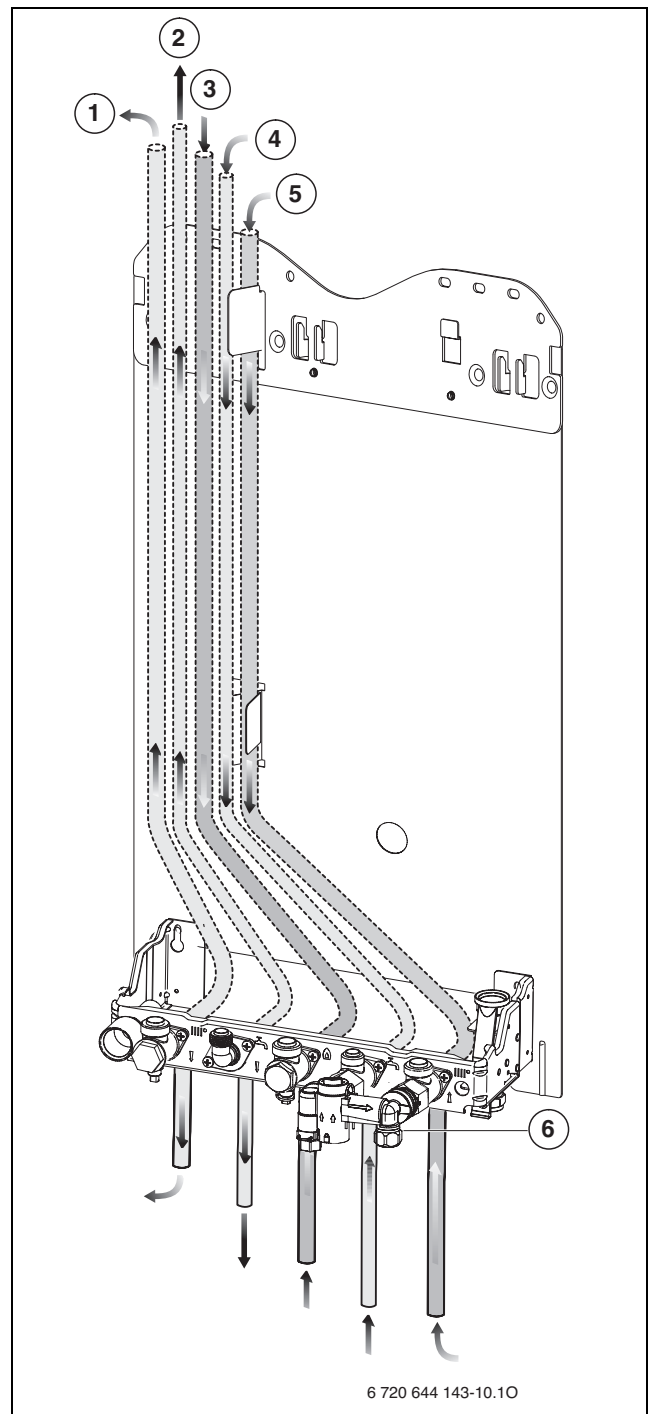

Fig. 18 Pipework

- 1 Heating flow
- 2 ZWB: DHW  
ZSB: Cylinder flow
- 3 Gas
- 4 ZWB: Cold water  
ZSB: Cylinder return
- 5 Heating return
- 6 Filling loop (ZWB)

## 6.5 Fitting the appliance



**NOTE:** Dirt and corrosion in the pipework can damage the appliance.

- ▶ Flush out the system to remove all dirt residues.

- ▶ Remove packing, taking care to observe the instructions on the packing.
- ▶ Check the destination country on the type plate and make sure that the gas type specified on the identification plate matches that of the gas supplied by the gas utility company (→ page 10).

### Removing the outer casing



The casing is secured with two screws to prevent against unauthorised removal for electrical safety.

- ▶ Always secure the outer casing with these screws.

- ▶ Untighten the screws.
- ▶ Lift bracket and remove casing towards the front.

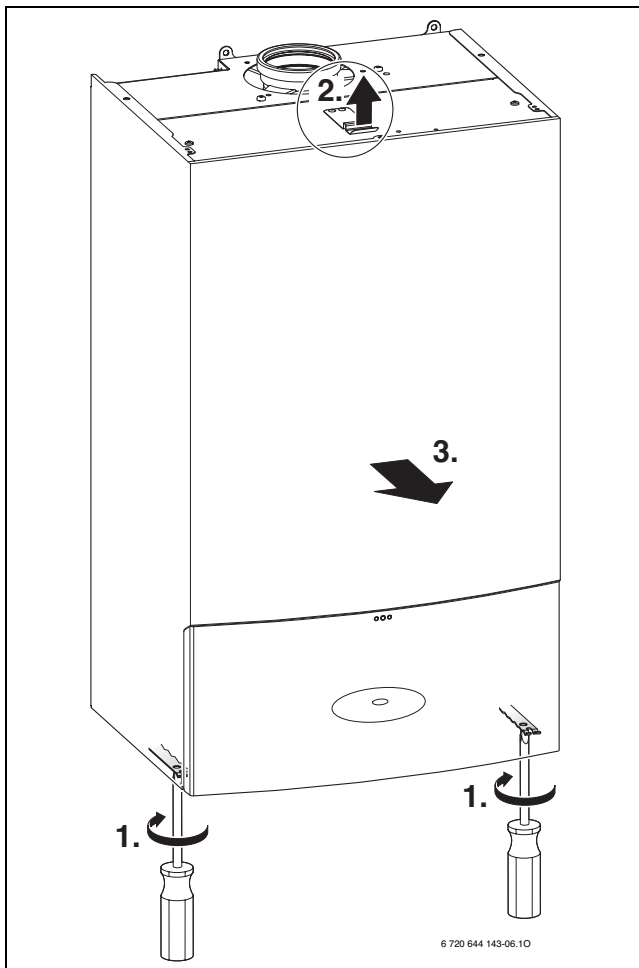

Fig. 19

### Preparing for fixing

- ▶ Place sealing washers on the pre-plumbing jig connections.
- ▶ Pull lever on pressure relief valve connection forwards and push down as far as it will go (→ Fig. 12).

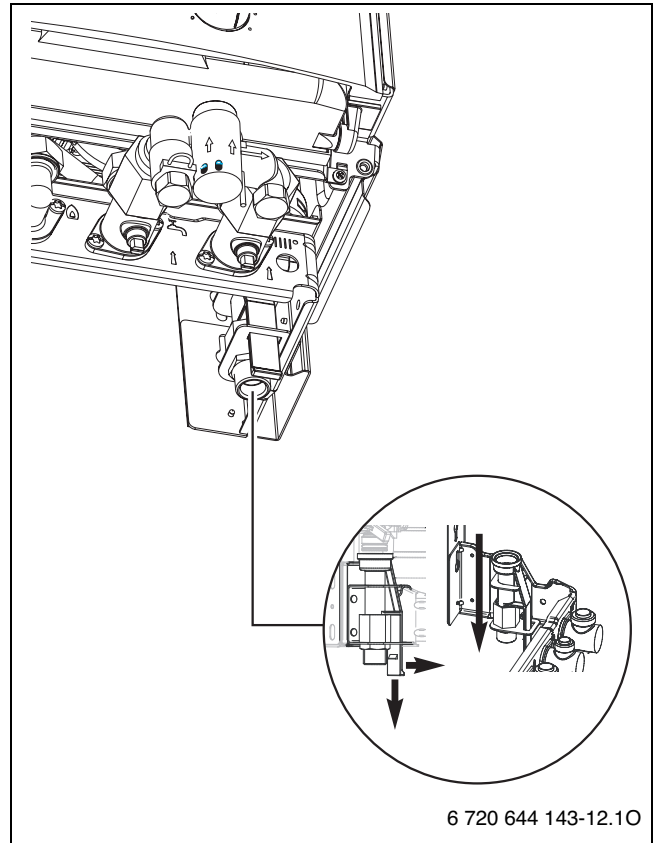

Fig. 20

### Securing the appliance

- ▶ Hook appliance into the mounting rail at the top and position it at the bottom on the prepared pipework connections.
- ▶ Tighten the union nuts on the pipe connections.

### Drain from pressure relief valve (heating circuit)

- ▶ Push lever on slider up until catch [1] rests on metal bracket [2] (→ Fig. 13).

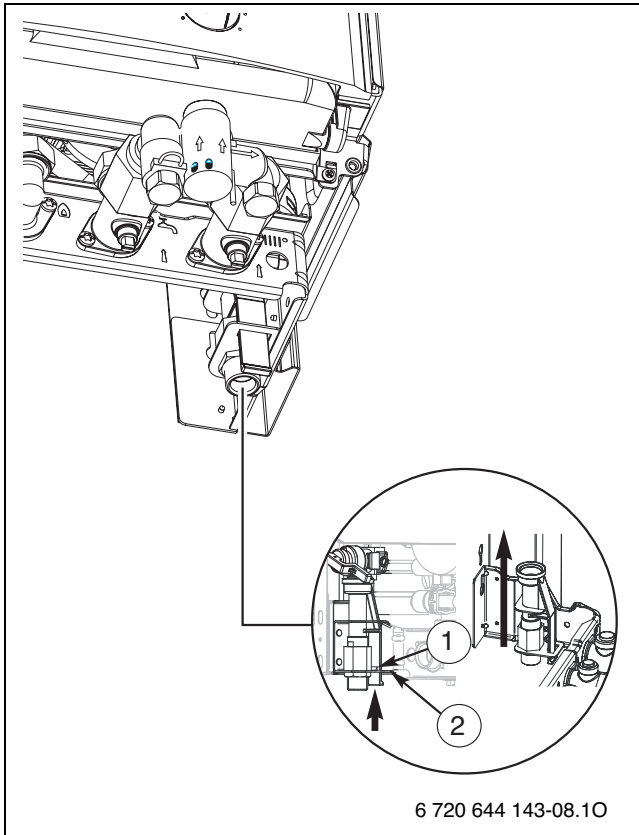

Fig. 21

- ▶ Route the drain line where it will be easily visible in the frost-protected area to a drainage point.



**WARNING:** Risk of scalding

Hot water or steam can lead to scalding

- ▶ Stay clear of the pressure relief outlet during operation of the appliance.

### Creating the condensate drain

- ▶ Push the condensate hose into the adaptor on the pre-plumbing jig.
- ▶ Create the drain.
- ▶ Do not use copper pipe.



**CAUTION:**

- ▶ Do not modify or seal off drain pipes.
- ▶ Hoses must always slope downwards.

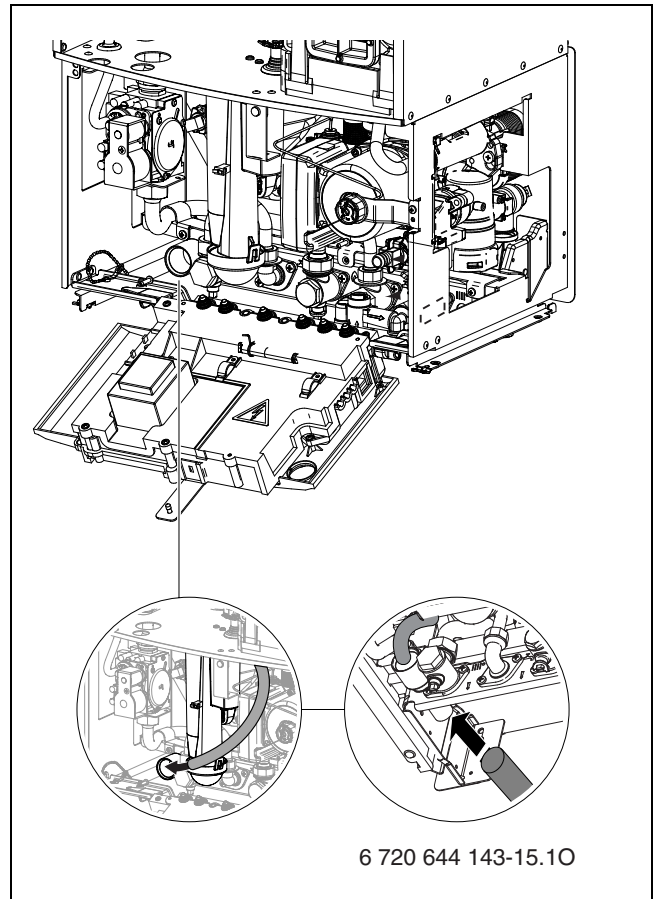

Fig. 22



**NOTE:**

- ▶ Ensure there are no blockages in the pipe run.
- ▶ Insulate external pipework when freezing conditions can occur.

### Fitting the filling loop (ZWB)

- ▶ Close the isolating valves on the mains water inlet [9] and the CH return [1] connections.
- ▶ Remove the blanking plugs [2].
- ▶ Place the filter [7] into the inlet side of the filling loop [4] ensuring that the filter mesh faces into the filling loop.
- ▶ Fit the filling loop [4] to the mains water inlet [9] and CH return [1] connections. Ensure that the filling loop is completely pushed into the stop tabs [6, 3] on both sides of the filling loop.
- ▶ Fit two screws and washers [8] to each of the two connections [9] and [1]. Do not try to turn the brass hexagon connectors.

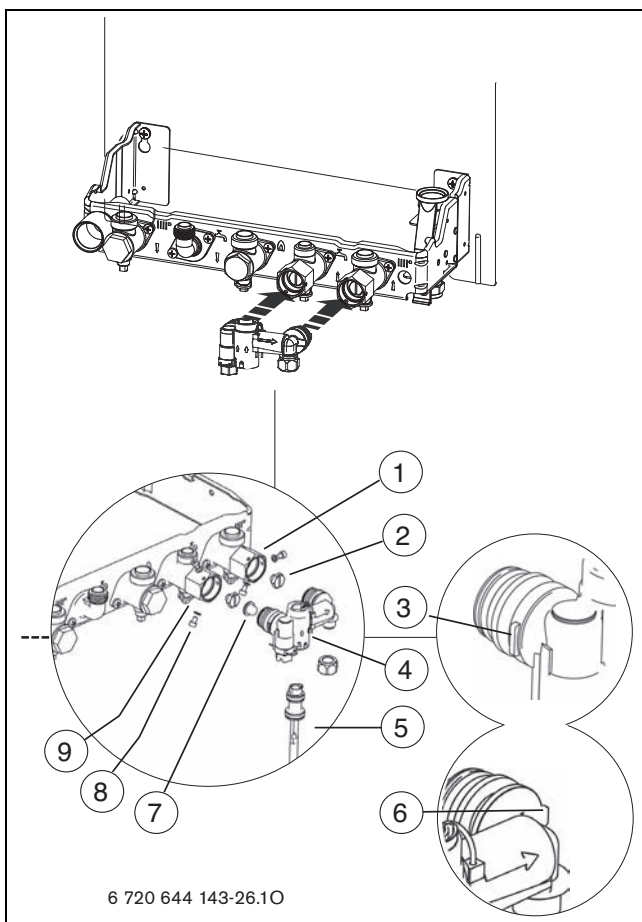



Fig. 23

### Filling the heating circuit (ZWB)

- ▶ Ensure that all system and boiler drain points are closed.
- ▶ Tighten screw [1] on the filling loop as far as it will go (→ Fig. 24).
- ▶ Open the cold water supply tap [3] and heating return tap [2].
- ▶ Insert key [4] in the filling direction so the arrow points to symbol .
- ▶ Turn key [4] to position .
- ▶ Fully undo screw [1] on the filling loop and fill the heating circuit to a pressure of 1 - 2 bar.

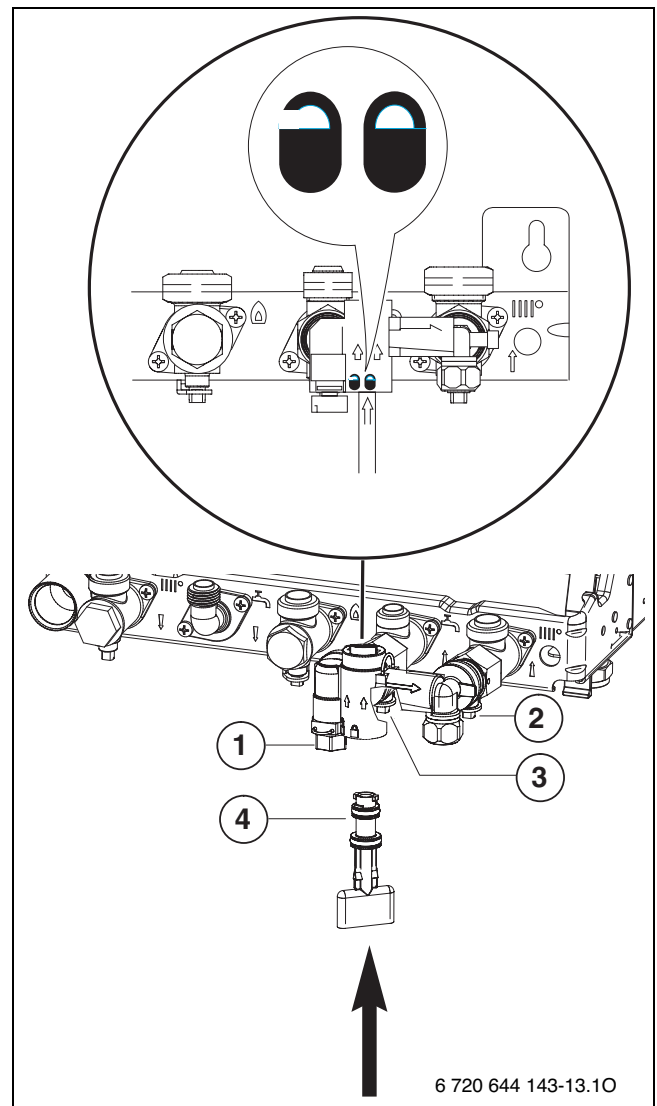

Fig. 24

- ▶ After filling, turn in screw [1] as far as it will go.

- ▶ Turn key [4] to position , remove and insert into the lower cover.

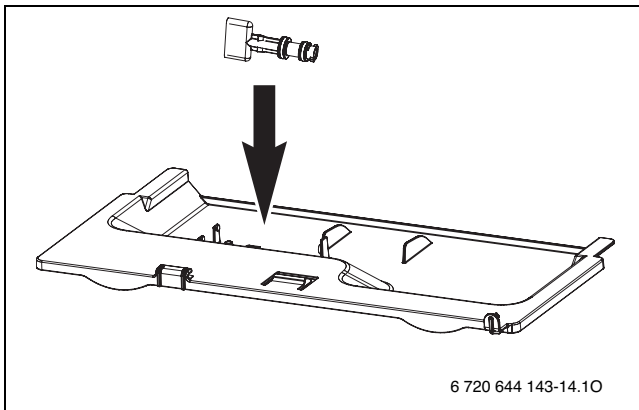

Fig. 25

### Fitting the lower cover

- ▶ Push the lower cover into the two guide rails at the bottom of the appliance.

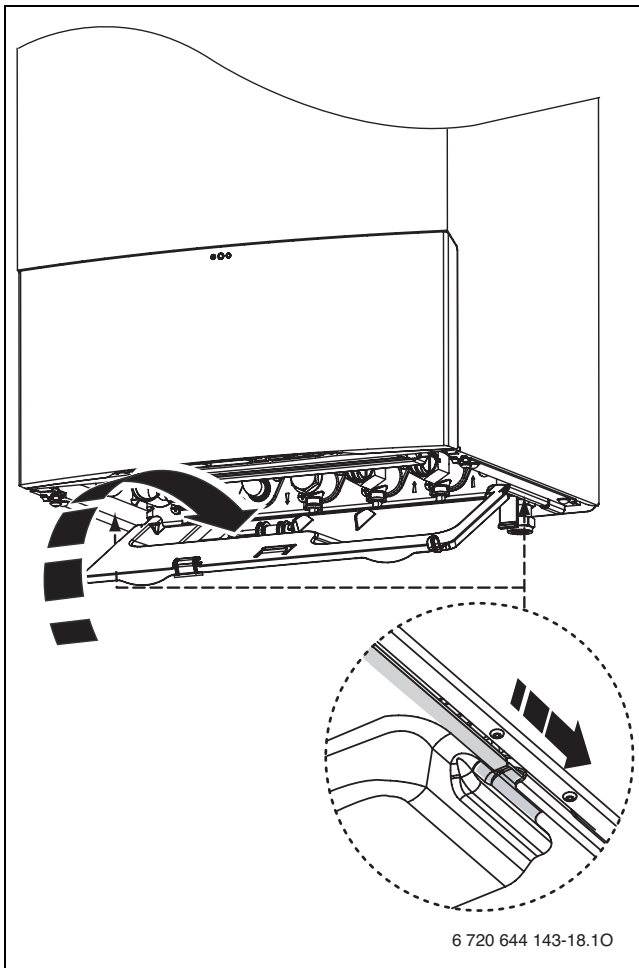

Fig. 26

### Connecting the flue pipe

- ▶ Push on the flue gas accessories and secure with the screws supplied.



For more precise details of connecting the flue, refer to the installation instructions for the flue routing manual.

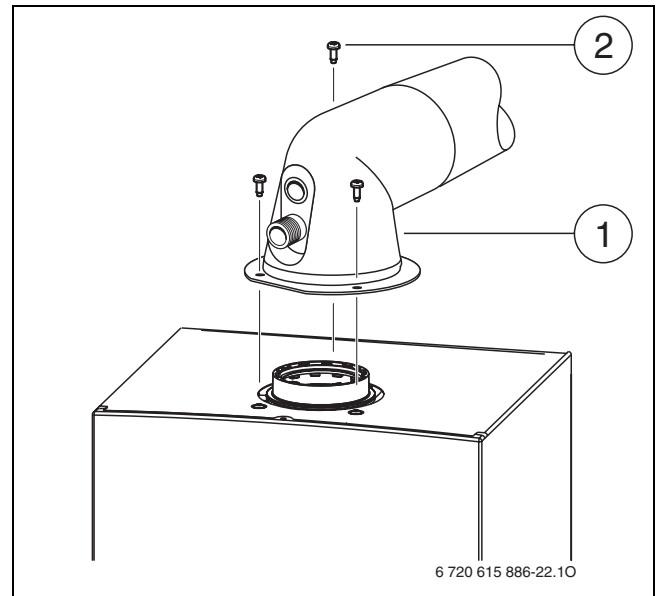

Fig. 27 Fitting the flue kit

- 1 Flue/adaptor
- 2 Screws

- ▶ Check the flue gas path for tightness (→ chapter 13.2).

---

## 6.6 Checking the connections

### Water connections

- ▶ Open the heating flow and return valves and fill the heating system.
- ▶ Check sealing points for leaks (testing pressure: max. 2.5 bar (250 kPa) at the pressure gauge).
- ▶ Open the cold water valve on the appliance and a turn on a hot water tap until water runs out. Max pressure: 10 bar (1000 kPa).

### Gas supply pipe

- ▶ Close the gas valve to protect the gas valve from pressure damage.
- ▶ Check sealing points for leaks.
- ▶ Release the pressure on the gas supply pipe.

## 7 Electrical connections

### 7.1 General information



**DANGER:** Risk of electric shock!

- ▶ Before carrying out work on electrical components, disconnect the power supply (230 V AC) (fuse, circuit breaker) and secure against unintentional reconnection.

- Supply: 220 - 240 V, 50 Hz.
- The appliance must be earthed.
- All pipes to the appliance must be earthed.

All appliance modulation, control and safety components are tested and ready-wired for use.

Observe safety measures according to the relevant regulations and AS/NZS 3000.

No other electrical consumer units may be connected to the same power cable.

#### Fuses

The appliance is protected by three fuses. They are located on the circuit board (→ Fig. 4, page 12).



Replacement fuses can be found on the back of the cover (→ Fig. 29).

### 7.2 Connecting accessories

#### Opening the Heatronic unit



**CAUTION:** Cable offcuts can damage the Heatronic.

- ▶ Always strip cables away from the Heatronic.

- ▶ Slide the clip down and pivot the Heatronic.

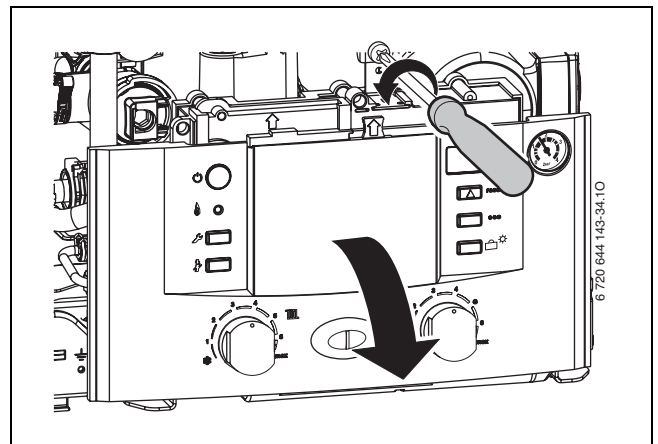

Fig. 28

- ▶ Remove screws, unhook cable and remove cover.

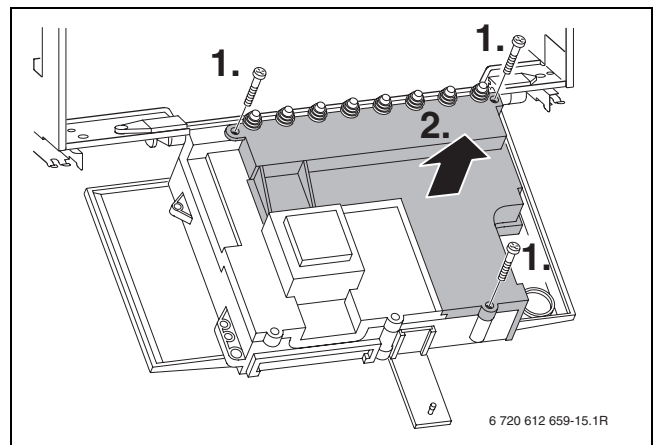

Fig. 29

- ▶ To provide anti-splash protection (IP), always cut cable grip to fit cable diameter.

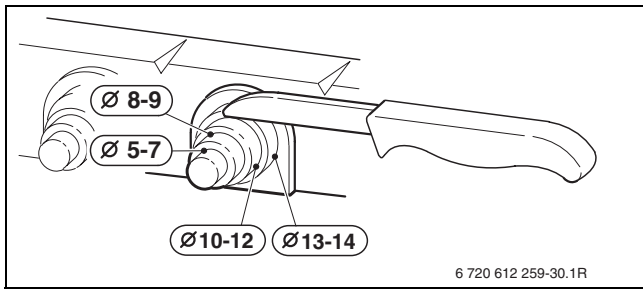

Fig. 30

- ▶ Feed cable through cable grip and connect as appropriate.
- ▶ Secure cable in cable grommet by means of cable grip.

### 7.2.1 Connecting the heating controller or remote control units

Only operate this appliance with a Bosch controller.

Heating controller FW 100 can also be mounted right at the front in the Heatronic 3.

For installation and electrical connection, see the relevant installation instructions.

### 7.2.2 Connecting the DHW cylinder



Replace existing cylinder temperature sensor with Bosch cylinder temperature sensor.

Cylinders with Bosch cylinder temperature sensors are connected directly to the appliance PCB.

- ▶ Snap off the plastic tongue.
- ▶ Insert the cylinder temperature sensor lead.
- ▶ Plug the connector into the PCB.

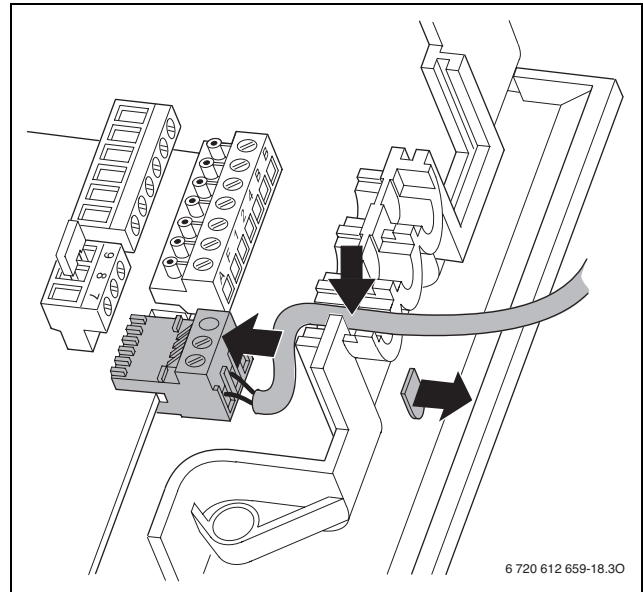

Fig. 31

### 7.2.3 Connecting temperature limiter TB 1 from the flow of an underfloor heating system

Only for underfloor heating systems connected directly to the appliance.

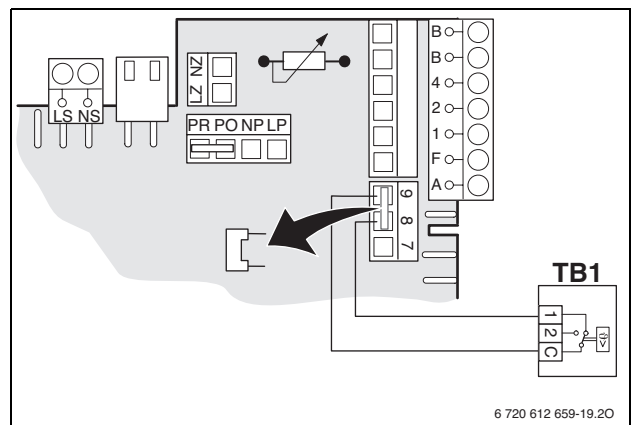
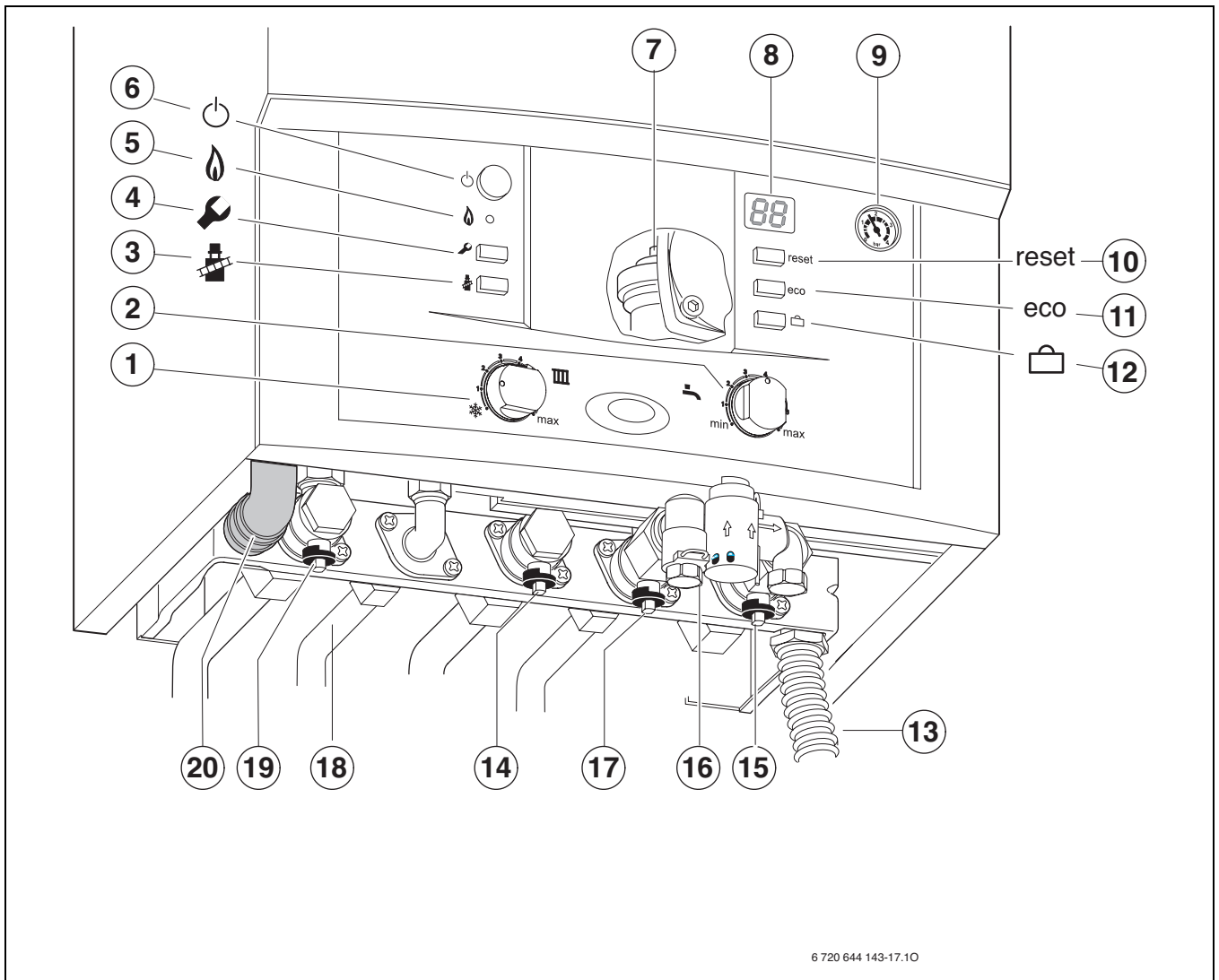

Fig. 32

If the temperature limiter trips, central heating and DHW modes are interrupted.

## 8 Commissioning



6 720 644 143-17.10

Fig. 33

- 1 Flow temperature control
- 2 DHW temperature control
- 3 Chimney sweep button
- 4 Service button
- 5 Burner ON indicator
- 6 Main switch
- 7 Automatic air vent valve
- 8 Display
- 9 Pressure gauge
- 10 reset button
- 11 eco button
- 12 Holiday button
- 13 Drain from pressure relief valve (heating circuit)
- 14 Gas tap
- 15 CH return isolator
- 16 Filling loop (ZWB)
- 17 Cold water tap (ZWB),  
cylinder return (ZSB)
- 18 DHW connection (ZWB),  
cylinder flow (ZSB)
- 19 CH flow isolator
- 20 Condensate hose

## 8.1 Before commissioning



**NOTE:** Commissioning without water destroys the appliance!

- ▶ Never run the appliance without water in it.

- ▶ Adjust pre-charge pressure of expansion vessel to static head of the heating system (→ page 25).
- ▶ Open all system radiator valves.
- ▶ Open cold water tap (→ Fig. 33, [17]) and one DHW tap until water flows out.
- ▶ Open heating flow and return taps [19 and 15] and fill heating system to 1 to 2 bar (100 - 200 kPa) (via filling loop [16]) and close filling tap.
- ▶ Bleed radiators.
- ▶ Top up heating system to pressure of 1 - 2 bar (100 - 200 kPa).
- ▶ Check that the gas type specified on the type plate matches that of the gas supply.
- ▶ Open gas tap [14].
- ▶ Do not operate the appliance if the flue terminal fitted on the outside wall or roof is obstructed or damaged.
- ▶ Check that the pressure relief connector, located on the right hand side at the bottom of the wall frame, is in its up position.
- ▶ Check that the condensate pipe has been connected to the adaptor.
- ▶ Briefly open the pressure relief valve to test its operation.

## 8.2 Switching the appliance on/off

### Switching on

- ▶ Switch appliance on at the main switch. The display shows the heating water flow temperature.

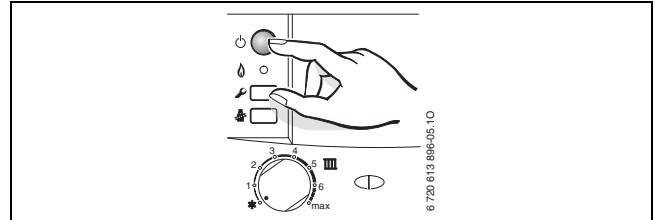



Fig. 34



When the appliance is switched on for the first time, it performs a once-only venting sequence. This involves the heating circuit pump switching on and off at intervals (for approx. 8 minutes). The display shows  in alternation with the flow temperature.

- ▶ Open automatic air vent valve [7] and close again after venting (→ page 35).



If the display shows  in alternation with the flow temperature, the trap filling function is active (→ page 48).

### Switching off the appliance

- ▶ Switch appliance off at the main switch. The display goes out.
- ▶ If the appliance is to be switched off for a longer period of time: observe correct frost protection procedures (→ chapter 8.9).

### 8.3 Starting the central heating

The maximum flow temperature can be matched to the heating system by the flow temperature controller. The current flow temperature is shown on the display.



Setting on flow temperature controller 	Flow temperature	Sample application
1	Approx. 35 °C	
2	Approx. 43 °C	
3	Approx. 50 °C	Underfloor heating system
4	Approx. 60 °C	
5	Approx. 67 °C	
<b>6</b>	<b>Approx. 75 °C</b>	Radiator heating system
max.	Approx. 90 °C	Convactor heating system

Table 12



With underfloor heating systems, take care to observe the maximum permissible CH flow temperatures.

- ▶ Turn flow temperature controller  to adjust the maximum flow temperature.

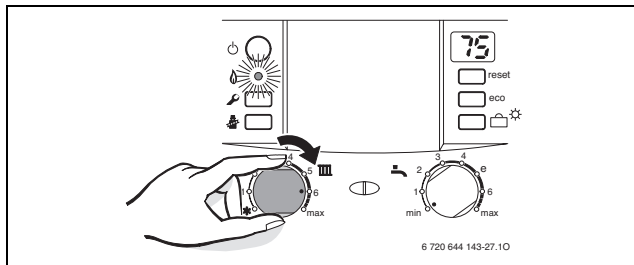

Fig. 35

When the burner is firing, the green indicator lamp lights up.

### 8.4 Setting the heating control unit



Follow the operating instructions for the heating controller used. Those instructions will tell you

- ▶ how to set the operating mode and the heating curve for weather-dependent controllers,
- ▶ how to adjust the room temperature,
- ▶ how to heat economically and save energy.

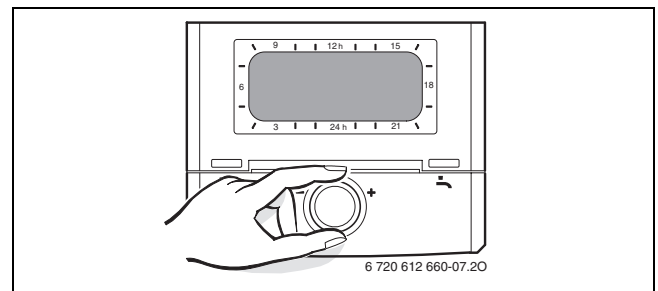

Fig. 36

### 8.5 After commissioning

- ▶ Check the gas supply pressure (→ page 52).
- ▶ Check the condensate drain to ensure that condensate runs out. If that is not the case, switch the main switch off and on again. This activates the siphon filling program (→ page 48). Repeat this procedure several times until condensate starts running out.
- ▶ Record the settings in the commissioning report (→ page 74).
- ▶ Affix the “Heatronic settings” label to the casing in a clearly visible position (→ page 43).

## 8.6 Appliances with hot water cylinder: setting the hot water temperature



**WARNING:** Danger of scalding!

- ▶ In normal operation, do not set the temperature higher than 60 °C.

- ▶ Set the DHW temperature on the DHW temperature control . The set DHW temperature flashes on the display for 30 seconds.

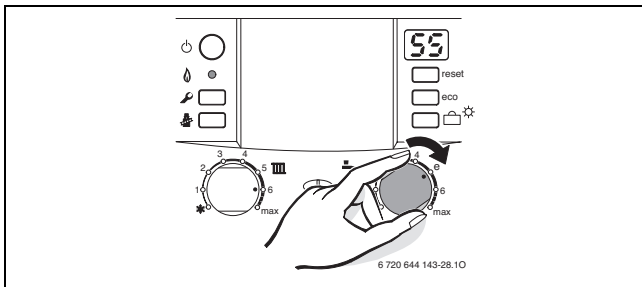



Fig. 37



To prevent bacterial contamination such as legionella, we recommend setting the DHW temperature controller  to at least “6” (60 °C).

This setting ensures economical and convenient DHW heating.

DHW thermostat 	DHW temperature
min	Approx. 5 °C (frost protection)
e	Approx. 55 °C
6	Approx. 60 °C
max.	Approx. 70 °C

Table 13

### eco button

Pressing and holding the eco button until it lights up switches between **Comfort mode** and **Economy mode**.

#### Comfort mode, Eco button is not lit (default setting)

In Comfort mode, the hot water cylinder has priority. The hot water cylinder is heated to the set temperature first. Then the appliance switches to central heating mode.

#### Economy mode, Eco button lit

In Economy mode, the appliance switches between central heating mode and hot water mode every ten minutes.

## 8.7 ZWB appliances - setting hot water temperature

- ▶ Set the DHW temperature on the DHW temperature control . The set DHW temperature flashes on the display for 30 seconds.

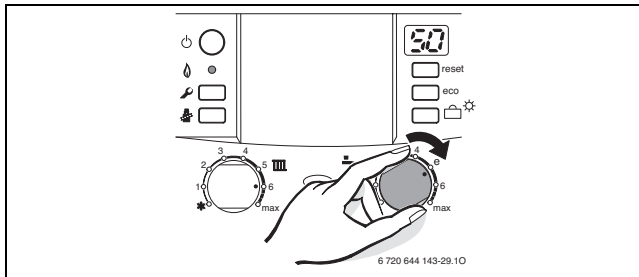

Fig. 38

DHW thermostat 	DHW temperature
min	Approx. 40 °C
e	Approx. 50 °C
max.	Approx. 60 °C

Table 14

### eco button

Pressing and holding the eco button until it lights up switches between **Comfort mode** and **Economy mode**.

### Comfort mode, (Eco button is not lit - default setting)

The appliance is held **constantly** at the set temperature. This means that hot water is available almost instantaneously at the tap. Consequently the appliance will switch on at intervals, even if no hot water is being drawn.

### Economy mode, Eco button lit

- The water is not heated up until a hot water tap is turned on.
- **With a demand signal**  
Briefly turning a hot water tap on and then off signals demand so that the water is then heated up to the set temperature.





The demand signal enables gas and water savings.

### Hot water supplied to sanitary fixtures

In accordance with AS 3498 a temperature control device limited to +50 °C, such as a tempering valve must be fitted when hot water is supplied to sanitary fixtures used primarily for the purposes of personal hygiene.

## 8.8 Summer mode (central heating off, DHW only)

- ▶ Note position of CH flow temperature control .
- ▶ Turn CH flow temperature control  anti-clockwise as far as the stop . The heating circuit pump and consequently central heating are switched OFF. However, the DHW supply as well as the power supply to the heating programmer and timer remain 'live'.

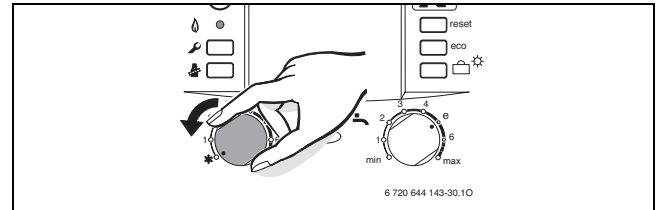

Fig. 39



**NOTE:** Heating system at risk from frost.

Additional instructions are contained in the operating instructions for the heating programmer.

## 8.9 Frost protection

### Frost protection for the heating system:

- ▶ Leave appliance switched on, set CH flow temperature control  to position 1 at least.

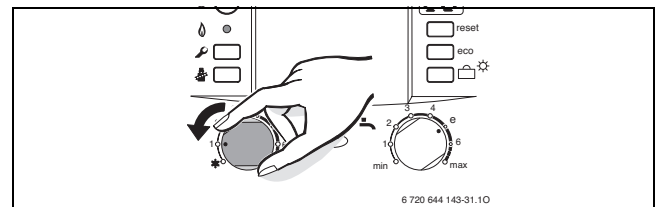

Fig. 40

- ▶ Add anti-freeze to the heating water (→ page 24) and drain the DHW circuit.

Additional instructions are contained in the operating instructions for the heating programmer.

### Frost protection for the cylinder:

- ▶ Turn DHW temperature controller counter clockwise as far as it will go (5 °C).

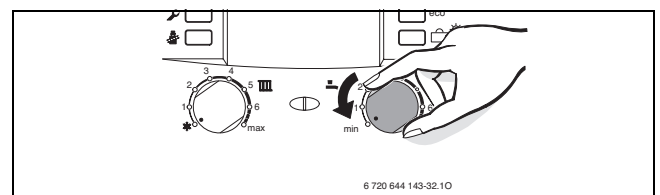



Fig. 41

## 8.10 Holiday mode

To switch on holiday mode:

- ▶ Press and hold holiday button  on the appliance until it lights up, and switch on holiday mode on the heating controller.

In holiday mode, heating and DHW heating are switched off; frost protection remains active (→ chap. 8.9).

To switch off holiday mode:

- ▶ Press and hold holiday button  on the appliance until it goes out, and cancel holiday mode on the heating controller.

The appliance returns to operation in standard mode according to the settings at the heating control unit.

## 8.11 Fault mode

All safety, modulation and control components are monitored by the Heatronic system.

If a fault occurs during operation, a warning tone sounds.



If you press a button, the warning tone stops.

The display indicates a fault and the reset button may also flash.

If the reset button flashes:

- ▶ Press and hold the reset button until the display shows . The appliance will start up again and the flow temperature will be displayed.

If the reset button does not flash:

- ▶ Switch the appliance off and then on again at the main switch. The appliance will start up again and the central heating flow temperature will be displayed.

If the fault persists:

- ▶ Contact your authorised contractor or customer service for assistance, providing details of the fault and the appliance (→ page 7).



For an overview of faults, see page 67.  
For an overview of displays, see page 64.

## 9 Thermal disinfection on appliances with hot water cylinder

To prevent the DHW becoming contaminated by bacteria such as legionella, we recommend you pasteurise the system after longer idle periods.



With some heating controllers, thermal disinfection can be programmed for a fixed time; see heating controller operating instructions.

Pasteurisation covers the DHW system including the draw-off points. For solar DHW cylinders, the solar portion of the cylinder is not covered.



**WARNING:** Risk of scalding!

Hot water can lead to severe scalding.

- ▶ Only carry out thermal disinfection at times when the system is not normally in use.
- ▶ The water in the cylinder will take a while to cool down to the set DHW temperature as a result of heat loss. Be aware that, after thermal disinfection, the hot water may be hotter than the set temperature.

- ▶ Turn off all hot water points.
- ▶ Warn occupants of risk of scalding.
- ▶ If the heating programmer has a DHW program, set the time and DHW temperature accordingly.
- ▶ If there is a circulation pump, set it to run continuously.
- ▶ Turn DHW temperature control clockwise as far as the stop (approx. 70 °C).

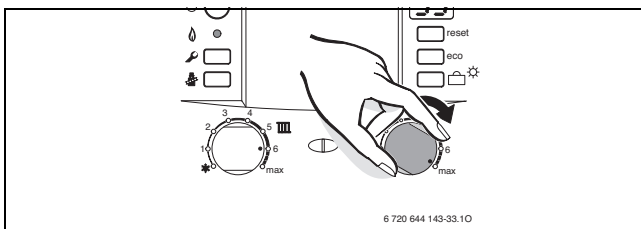

Fig. 42

- ▶ Wait until the water reaches the maximum temperature.
- ▶ Draw off water in turn from the nearest to the furthest hot water point until hot water has been running out at a temperature of 70 °C for 3 minutes.
- ▶ Reset DHW temperature control, circulation pump and heating programmer to their standard settings.

## 10 Pump anti-seizing function



This function prevents the heating circuit pump and the 3-way valve seizing up during long periods of inactivity.

---

Every time the pump is switched off, a timer starts to briefly switch on the heating circuit pump and the 3-way valve at regular intervals.



## 11.2 Overview of service functions

### 11.2.1 Service level 1

- ▶ Press service button  until it illuminates.

Service function		
Display code		Page
<b>1.A</b>	Max. output (heating)	45
<b>1.b</b>	Max. output (hotwater - ZWB only)	45
<b>1.C</b>	Pump map (heating)	45
<b>1.d</b>	Map pump step (heat.)	46
<b>1.E</b>	Pump switch mode	46
<b>2.b</b>	Max. flow temperature	46
<b>2.C</b>	Air purge mode(burner keeps off while air purge mode is on)	47
<b>2.F</b>	Operating mode	47
<b>3.b</b>	Anti-cycle time	47
<b>3.C</b>	Anti-cycle flow temperature differential	47
<b>3.E</b>	Pre heat cycle time (hot water)(ZWB only)	47
<b>3.F</b>	Burner off after DHW demand (hot water) (ZWB only)	47
<b>4.F</b>	Syphon-fill programme	48
<b>5.A</b>	Reset service reminder	48
<b>5.b</b>	Fan run-on time	48
<b>6.A</b>	Last fault	48
<b>6.d</b>	Actual flow rate turbine (ZWB only)	48
<b>6.E</b>	Programmer input	48
<b>7.A</b>	Fault indicator LED on/off	48

Table 15 Service functions, level 1

### 11.2.2 Service level 2

Access from service level 1; service button lights up.

- ▶ Press eco button and holiday button simultaneously until a code such as 8.A appears.

Service function		
Display code		Page
<b>8.A</b>	Software version	49
<b>8.b</b>	Code plug number	49
<b>8.C</b>	GFA status (not applicable)	49
<b>8.d</b>	GFA error (not applicable)	49
<b>8.E</b>	Reset all parameters	49
<b>8.F</b>	Permanent ignition	49
<b>9.A</b>	Operation mode permanent	49
<b>9.b</b>	Actual fan speed	49
<b>9.C</b>	Actual heat output	49
<b>9.d</b>	Start fan speed	49
<b>9.E</b>	Turbine signal delay (ZWB only)	49
<b>9.F</b>	Heating circuit pump run-on time	49

Table 16 Service functions, level 2

## 11.3 Description of service functions

### 11.3.1 Service level 1

#### Service function 1.A: MAX. OUTPUT (HEATING)

Some gas supply utilities charge a basic rate based on output.

The heating output can be set to any level between min. rated heat output and max rated heat output to limit it to the specific heat requirements.



Even if the output is limited, the full rated heat output remains available for hot water.

The factory setting is maximum rated heat output:

Appliance type	Display indication
ZSB 30 ...	U0 (100%)
ZWB 37 ...	84

Table 17

- ▶ Select service function 1.A.
- ▶ Refer to the settings tables (→ page 72) for the output in kW and the corresponding setting code.
- ▶ Enter the setting code.
- ▶ Measure the gas flow rate and compare with the figures for the setting shown. If they do not match, change the setting.
- ▶ Save the setting.
- ▶ Enter the selected output on the “Heatronic settings” label supplied (→ page 43).
- ▶ Exit service functions.  
The display will show the CH flow temperature again.

#### Service function 1.b: Max. output (hot water - only ZWB)

The hot water output can be set to any level between minimum rated hot water output and maximum rated hot water output to limit it to the specific hot water requirements.

**The factory setting** is maximum rated output – display shows U0.

- ▶ Select service function 1.b.
- ▶ Take the DHW output in kW and the associated parameter from the setting tables (→ page 72 to 73).
- ▶ Enter the setting code.
- ▶ Measure the gas flow rate and compare with the figures for the setting shown. If they do not match, change the setting.
- ▶ Save the setting.
- ▶ Enter the selected DHW output on the “Heatronic settings” label supplied (→ page 43).
- ▶ Exit service functions.  
The display will show the CH flow temperature again.

#### Service function 1.C: Pump map (heating)

The appliance is supplied with this function set to 4 (Proportional pressure high). See pump characteristics below.

The pump map indicates how the pump is controlled in heating mode. The pump switches between the various pump speeds so as to reproduce the characteristic curve selected.

Changing the pump characteristic can be helpful if a lower pressure difference will guarantee the necessary circulation on the basis of the system dimensions and pump characteristic.



In order to save as much energy as possible and to minimise the possibility of water circulation noise, a low characteristic should be chosen.

The following can be selected as the pump characteristic map:

- 00 Pump step adjustable, service function 1.d (→ page 46)
- 01 Constant pressure high
- 02 Constant pressure medium
- 03 Constant pressure low
- 04 Proportional pressure high
- 05 Proportional pressure low

The factory setting is **04**.

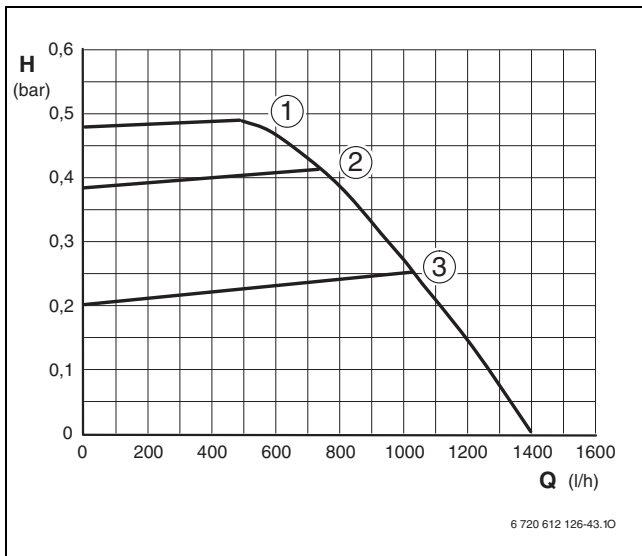

Fig. 45 Constant pressure

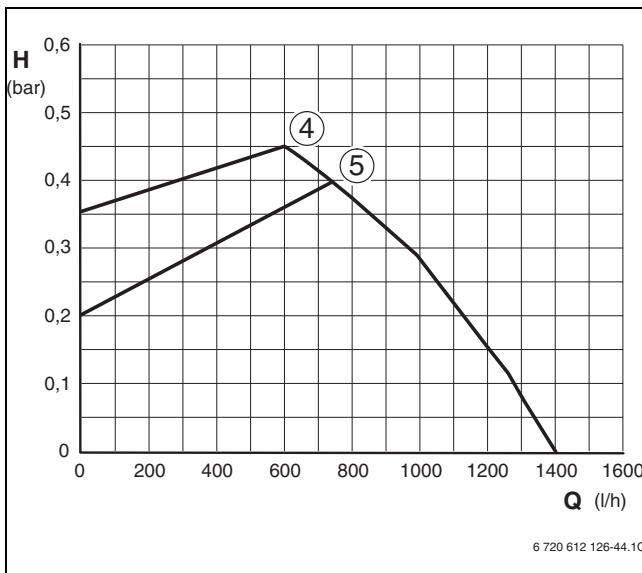

Fig. 46 Proportional pressure

**Legend for Fig. 45 and 46:**

- 1-5** Characteristics
- H** Pressure
- Q** Water circulation rate

**Service function 1.d: Map pump step (heating)**

This service function corresponds to the pump speed switch used on conventional heating pumps. However, the setting is only active if function **1.C** (Pump map (heating)), is set to **0**.

The factory setting is **07**.

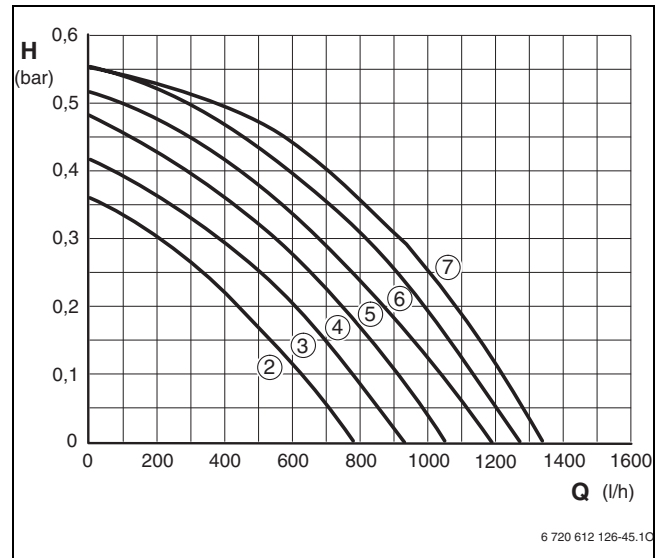

Fig. 47 Characteristics

**Key to Fig. 47:**

- 1-7** Characteristics
- H** Pressure
- Q** Water circulation rate

**Service function 1.E: Pump switch mode**

- **Pump control mode 0:**  
The BUS controller controls the central heating circuit pump.
- **Pump control mode 1:**  
The pump is controlled by the central heating flow temperature control.
- **Pump control mode 2 (factory setting):**  
For heating systems with room thermostat. The central heating flow temperature control controls only the gas, the pump is not affected. The room thermostat controls both the gas and the pump. The pump and fan have an over-run time of between 15 s and 3 min.
- **Pump control mode 3:**  
Not applicable.

**Service function 2.b: Maximum flow temperature**

The maximum CH flow temperature can be set to between 35 °C and 88 °C. Even if the CH flow temperature control is set higher, the setting entered for 2.b (Max. flow temperature) is not exceeded.

The factory setting is **88**.

### Service functions 2.C: Air purge mode

The first time the appliance is switched on, a once-only venting function is activated. The heating pump then switches on and off at intervals. This sequence lasts about 8 minutes.

The 2-digit display shows  in alternation with the flow temperature.

The automatic vent will open during venting and then close once the venting sequence is complete.





The venting function can be activated after servicing.

If the venting function is set to “On” (with automatic deactivation), the function is set to “Off” once the sequence has been completed.

### Service function 2.F: Operating mode

There are 3 operating modes to choose from.

- **Normal mode:** the appliance operates according to the commands received from the programmer. The display shows **0**.
- **Minimum mode:** the appliance runs constantly at minimum output.  
The display shows **1**. The 2-digit display alternates between the CH flow temperature and . After 15 min. the minimal mode changes to normal mode.
- **Maximum mode:** the appliance runs constantly at maximum output.  
The display shows **2**. The 2-digit display alternates between the CH flow temperature and . After 15 min. the maximal mode changes to normal mode.

The factory setting is **0**.

### Service function 3.b: Anti-cycle time

The anti-cycle time is factory set to 3 minutes.

The shortest possible anti-cycle time is 1 minute (recommended for single-pipe and hot-air heating systems).

If the setting 0 is entered, the anti-cycle time is disabled.

- ▶ Enter the anti-cycle time on the commissioning record enclosed with the appliance.

### Service function 3.C: Anti-cycle flow temperature differential

The switching difference is the permissible differential from the specified CH flow temperature. It can be set in increments of 1 K. The adjustment range is 0 to 30 K. The minimum CH flow temperature is 35 °C.



Note: 1 K = 1 °C.

- ▶ Enter the switching difference setting on the commissioning record supplied with the appliance.

The factory setting is **10 K**.

### Service function 3.E: Cycle time (Hot water) (ZWB only)

The appliance is supplied with the pre-heat cycle time set to 20 minutes.

After pre-heating or DHW demand, this function will stipulate the period of time before the next permissible pre-heat. This will prevent excessive pre-heat cycling.

### Service function 3.F: Burner off after DHW demand (Hot water - ZWB only)

The appliance is supplied with the hot water duration set to 1 minute.

The “hot water duration” time specifies how long, after hot water has been drawn, that the heating mode remains disabled.

**Service function 4.F: Siphon-fill programme**

The syphon filling function ensures that the syphon trap is filled when the appliance is first installed or shut down for a long period. Flue gas is prevented from escaping into the room where the appliance is installed.

The trap filling function is activated when:

- the appliance is switched on at the main switch
- the burner has not been in use for at least 48 hours
- the appliance is switched from summer to winter mode

The next time the heating or hot water system calls for heat, the appliance is held at minimum output for 15 minutes.

The syphon filling programme remains active until the appliance has completed 15 minutes of operation at minimum output.

The 2-digit display alternates between  $\frac{1}{2}$  and the CH flow temperature.



**DANGER:** If the syphon is not filled, flue gas can escape.

- ▶ Only deactivate the syphon filling programme in order to carry out servicing work.
- ▶ Always re-activate trap filling programme once servicing is complete.

**Service function 5.A: Reset service reminder**

The burner service interval of 2324 hours has run out. After the service inspection store 0 for resetting the service interval.

**Service function 5.b: Fan over-run time**

- ▶ Set the time of fan over-run after a boiler demand.

**Service function 6.A: Last fault**

The last fault can also be recalled for servicing purposes when the appliance is functioning correctly.

**Service function 6.d: Current turbine flow rate (ZWB only)**

The actual flow rate of the turbine is displayed.

**Service function 6.E: Programmer input**

Shows the status of channel 1 of the timer DT10/20. Left digit is "Heat demand", heating mode will be activated according to the programmer commands. Shows the status of channel 2 of the timer DT20. Right digit is "DHW demand", hot water mode will be activated according to the programmer commands.

**Service function 7.A: Fault indicator LED ON/OFF**

The fault indicator LED flashes in case of error even when its setting is off (0).

### 11.3.2 Service level 2

#### Service function 8.A: Software version

The version number of the software is displayed.

#### Service function 8.b: Code plug



The 4-digit part number of the code plug (digits no. 7 upto 10 of order no.) is indicated.

The code plug determines the appliance functions. If the appliance is converted from natural gas to LPG or vice versa (using conversion kit) the code plug also has to be changed.

#### Service function 8.C: GFA status

(not applicable)

#### Service function 8.d: GFA error

(not applicable)

#### Service function 8.E: Reset all parameters

This function enables you to reset the appliance to the standard settings. All service functions that have been altered are reset to their standard settings.

To reset all settings on Service levels 1 and 2 to the factory settings:

- ▶ Display the value of the service function **8.E** (second service level, value = 0) and store it. The appliance restarts with factory settings.

#### Service function 8.F: Permanent ignition

This function allows permanent ignition without gas supply to be activated for the purposes of checking the ignition mechanism.



**NOTE:** Ignition transformer may be damaged.

- ▶ Do not run for more than 2 minutes.

#### Service function 9.b: Actual fan speed

The current fan speed is displayed in Hertz (Hz).

#### Service function 9.C: Actual heating output

This service function displays the current appliance heating output (in percent (%)).

#### Service function 9.d: Start fan speed

The actual start fan speed between 45 and 55 Hz is displayed in Hertz (Hz).

#### Service function 9.E: Turbine signal delay (ZWB only)

Sets a delay time relating to the beginning of DHW demand to avoid an undesired demand by water surge hammer.

#### Service function 9.F: Pump over-run time (CH mode)

Sets the time of pump over-run after the end of a heating demand.

#### Service function 9.A: Operation mode permanent

Set a fixed operation mode even when boiler has been switched off.

## 12 Converting the appliance to different gas types

The default gas setting of the appliance matches the gas type specified on the type plate.

Adjustment of the gas-air-ratio is only required when the appliance is converted to a different gas type.

**The gas-air ratio must always be set on the basis of a CO<sub>2</sub> or O<sub>2</sub> reading taken at maximum rated heat output and minimum rated heat output using an electronic tester.**

Adjustment to different flue systems using throttle discs or baffle plates is not necessary.

### NG

- Appliances for **natural gas** are factory-set to Wobbe index 50 MJ/m<sup>3</sup> and 11.3 mbar (1.13 kPa) supply pressure and sealed.

### LPG

- Appliances for **LPG** are factory-set to Wobbe index 76.9 MJ/m<sup>3</sup> and 27.5 mbar (2.75 kPa) supply pressure and sealed.

LPG type <sup>1)</sup>	Use
Commercial Propane	recommended
Commercial Butane	permitted
General Product	permitted
Universal LPG (U-LPG)	permitted

Table 18

1) according to NZS 5435



**WARNING:** Flue gas poisoning

When undefined gas mixtures (General Product and Universal LPG) are used, adjustment of gas values can lead to dangerous levels of carbon monoxide production.

- For any adjustment of the gas values use only Commercial Propane and Commercial Butane.

Commercial Propane can be used at any outside temperature.

Commercial Butane can only be used when the outside temperature is more than +5 °C.

We do not recommend the use of General Product and U-LPG. The mixture of propane and butane in General Product and U-LPG can vary depending on the amount of fuel in the tank and the production process, which makes precise adjustment of the gas values impossible.

### 12.1 Gas-type conversion

The following gas type conversion sets are available:

Appliance	Conversion to	Order No.
Z... 30-2 A	LPG	8 737 702 124 0
	NG	8 737 702 125 0
Z... 37-2 A	LPG	8 737 702 122 0
	NG	8 737 702 123 0

Table 19

### 12.2 Setting the gas-air ratio (CO<sub>2</sub> or O<sub>2</sub>)



**NOTE:** When running in central heating boost mode, the combi boiler will operate both the central heating and DHW circuits. This is to allow sufficient time for the setting procedure.

It will be necessary to turn on a hot water tap to run water through the DHW circuit to ensure that the boiler will not cycle on low heat demands.

- Switch appliance off at the main switch.
- Remove the outer casing (→ page 28).
- Switch appliance on at the main switch.
- Remove sealing plug from flue gas testing point.
- Insert a flue gas probe approx. 135 mm into the testing point socket and seal the testing point.

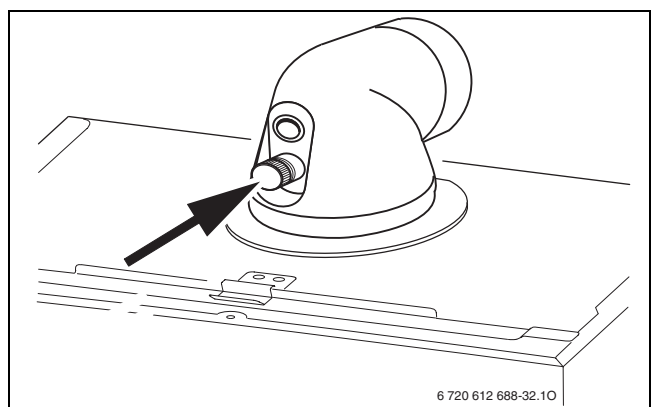





Fig. 48



**NOTE:** CO<sub>2</sub> should be measured 5 minutes after firing the appliance. To adjust the CO<sub>2</sub> or O<sub>2</sub> value it will be necessary to first operate the boiler at maximum output.

- ▶ Press and hold the central heating boost button  until it lights up.  
The display shows the flow temperature alternating with  = **maximum set heating output**.
- ▶ Briefly press the central heating boost button .  
The display shows the flow temperature in alternation with  = **maximum rated output**.



**NOTE:** Normal operation will resume after 15 minutes or if the central heating boost button is pressed for over a second.

- ▶ To adjust the maximum CO<sub>2</sub> or O<sub>2</sub> setting, locate the gas flow throttle under the fan unit.
- ▶ Remove the gas throttle seal with a screw driver as shown in Fig. 49.

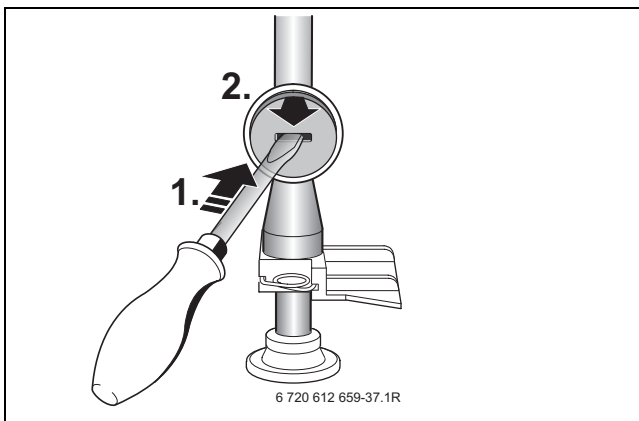

Fig. 49

- ▶ Adjust the gas flow throttle to set the CO<sub>2</sub> or O<sub>2</sub> level for maximum rated output with reference to the table 20.

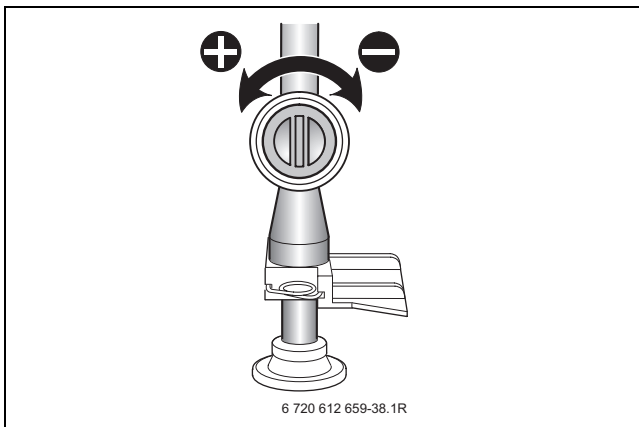

Fig. 50



Gas Type	max. rated heat output		min. rated heat output	
	CO <sub>2</sub> <sup>1)</sup>	O <sub>2</sub>	CO <sub>2</sub> <sup>1)</sup>	O <sub>2</sub>
NG (23)	9.6 %	3,6 %	9.0 %	4,7 %
LPG (Propane)	10.8 %	4.6 %	10.2 %	5.5 %
LPG (Butane)	12.2 %	2.8 %	11.5 %	3.8 %

Table 20

1) If the CO<sub>2</sub> value is beyond ± 0,5 % adjust.



- ▶ Appliances intended for use with LP gas (Propane or Universal) must initially be set on propane at 10.8 % (max.) and 10.2 % (min.) and at these CO<sub>2</sub> settings the appliance will operate satisfactorily on Universal LP gas.  
The exhaust of an appliance operating on Universal LP gas will however indicate a CO<sub>2</sub> concentration of up to 12.8 % but will need no adjustment.
- ▶ When checking an existing boiler the tolerance is ± 0,5 % CO<sub>2</sub>.
- ▶ If checking after cleaning or component replacement or for adjustment when the reading obtained is outside the tolerances given above, then the tolerance is ± 0.2 % CO<sub>2</sub>.

- ▶ Check if the CO value is less than 400 ppm dry and airfree. If this limit value is exceeded, reduce gas quantity.
- ▶ Briefly press the central heating boost button .  
The display shows the flow temperature in alternation with  = **minimum rated heat output**.
- ▶ Measure the CO<sub>2</sub> or O<sub>2</sub> level and check if it corresponds to the minimum output figure in the table 20.

- ▶ If not, remove the brass cap on the gas valve, covering the adjuster.
- ▶ Using a 4 mm Allen key adjust for the correct setting.
- ▶ Check if the CO value is less than 400 ppm dry and airfree.  
If this limit value is exceeded, reduce gas quantity.

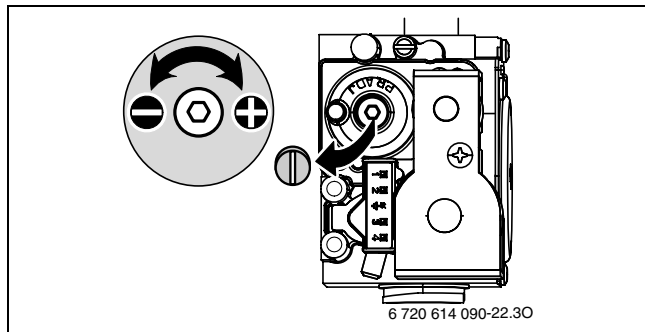



Fig. 51

- ▶ Re-check settings at maximum and minimum rated output and re-adjust if necessary.
- ▶ Repeatedly press the central heating boost button  until the light goes out.  
The display will show the CH flow temperature again.
- ▶ Record the CO<sub>2</sub> or O<sub>2</sub> levels in the commissioning log.
- ▶ Remove flue gas probe from flue gas testing point and refit sealing plug.
- ▶ Seal the gas valve and gas throttle.

### 12.3 Checking the gas supply pressure

- ▶ Switch off the appliance and turn off the gas cock.
- ▶ Undo the plug on the testing point for gas supply pressure and connect a pressure gauge.

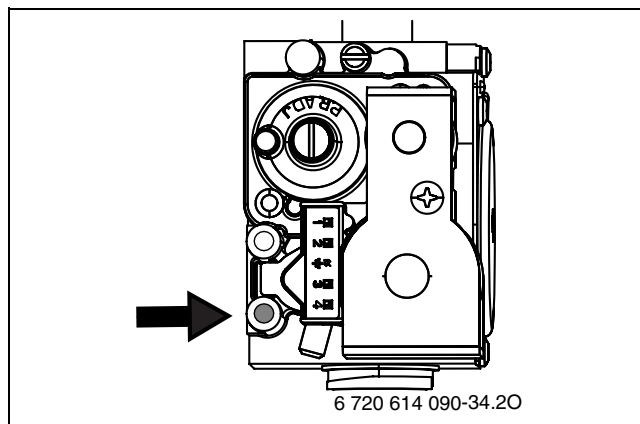





Fig. 52

- ▶ Turn on the gas tap and switch on the appliance.
- ▶ Press and hold the central heating boost button  until it lights up.  
The display shows the flow temperature alternating with  = **maximum set output**.
- ▶ Briefly press the central heating boost button .  
The display shows the flow temperature in alternation with  = **maximum rated output**.
- ▶ Check required gas supply pressure according to table.

Gas type	Permissible pressure range at max. rated output [mbar/kPa]
NG	11 - 30/1.1-3.0
LPG (Propane) <sup>1)</sup>	25 - 45/2.5-4.5
LPG (Butane)	25 - 35/2.5-3.5

Table 21

1) Standard figure for LPG with fixed cylinders with capacities up to 15 000 l



Never commission the appliance above or below these values. Identify and eliminate the cause. Where that is impossible, shut off the gas side of the appliance and notify the gas supply utility.

- ▶ Repeatedly press the central heating boost button  until the light goes out.  
The display will show the CH flow temperature again.
- ▶ Switch off the appliance, turn off the gas cock, remove the pressure gauge and refit the plug.
- ▶ Refit the outer casing.

## 13 Flue gas testing

### 13.1 Central heating boost button

The following appliance outputs can be selected by pressing the central heating boost button  until it lights up:

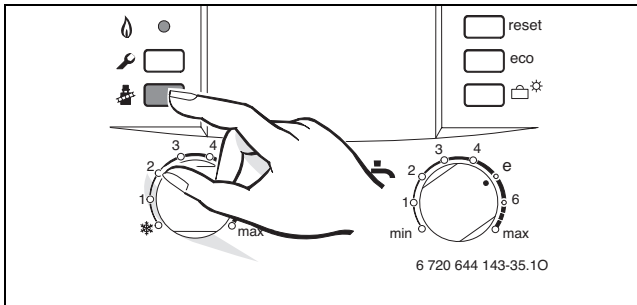





Fig. 53

-  = **max. heating output setting**
-  = **max. rated heat output**
-  = **min. rated heat output**



You have 15 minutes in which to take your measurements. Afterwards, the appliance returns to standard mode.

### 13.2 Checking flue system for leaks

Measuring  $O_2$  or  $CO_2$  levels in combustion air.

Use an annular-slot flue gas probe for the measurements.



With a type C<sub>13</sub>, C<sub>33</sub> or C<sub>93</sub> flue system, the **gas tightness of the flue system** can be tested by measuring the  $O_2$  or  $CO_2$  content of the combustion air. The  $O_2$  level must not be below 20,6 %. The  $CO_2$  level must not exceed 0,2 %.

- ▶ Remove sealing plug from combustion air testing point (2, → Fig. 54).
- ▶ Insert a flue gas probe into the testing point socket and seal the testing point.
- ▶ Press the central heating boost button to select  = **maximum rated output**.

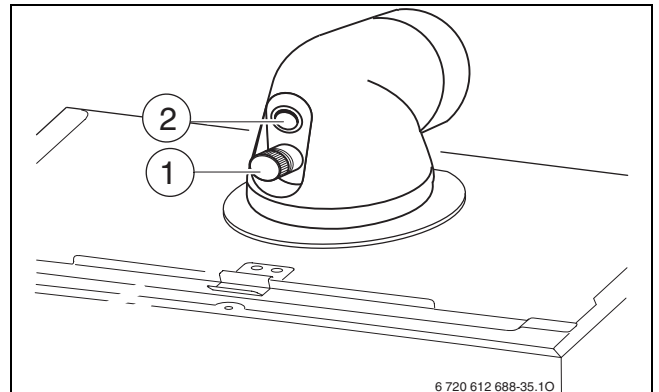

Fig. 54

- 1 Flue gas testing point
- 2 Combustion air testing point

- ▶ Measure the  $CO_2$  and  $O_2$  levels.
- ▶ Refit plug.

## 14 Environmental protection

Environmental protection is a fundamental corporate strategy of the Bosch Group.

The quality of our products, their economy and environmental safety are all of equal importance to us and all environmental protection legislation and regulations are strictly observed.

We use the best possible technology and materials for protecting the environment taking account of economic considerations.

### **Packaging**

Where packaging is concerned, we participate in country-specific recycling processes that ensure optimum recycling.

All packaging materials are environmentally compatible and can be recycled.

### **Used appliances**

Old appliances contain materials that should be recycled.

The relevant assemblies are easy to separate, and all plastics are identified. This allows the various assemblies to be appropriately sorted for recycling or disposal.

## 15 Inspection/Serviceing

To ensure that gas consumption and environmental impact remain as low as possible over an extended period of time, we recommend that you take out an inspection/serviceing contract with an authorised contractor covering an annual inspection, and serviceing at other times as required.



**DANGER:** Risk of explosion!

- ▶ Turn off gas valve before working on gas-carrying components.
- ▶ Check for leaks before working on gas-carrying components.



**DANGER:** Risk of poisoning!

- ▶ Check for leaks before working on gas-carrying components.



**DANGER:** Risk of electric shock!

- ▶ Before carrying out work on electrical components, disconnect the power supply (230 V AC) (fuse, circuit breaker) and secure against unintentional reconnection.



**WARNING:** Risk of scalding!

Hot water can cause severe scalding

- ▶ Drain the appliance before working on components that carry water.



**NOTE:** Leaking water may damage the Heatronic module.

- ▶ Cover the Heatronic module before working on any parts that carry water.

### Important notes



For an overview of faults, see page 67.

- The following test equipment is required:
  - Electronic flue gas emission meter for CO<sub>2</sub>, CO and exhaust temperature
  - Pressure gauge for 0 - 30 mbar (0 - 3 kPa) (resolution at least 0.1 mbar (0.01 kPa))
- Special tools are not required
- Permissible lubricants:
  - For components in contact with water: Unisilikon L 641 (8 709 918 413)
  - Unions: HFt 1 v 5 (8 709 918 010).
- ▶ Use 8 719 918 658 as heat conducting paste.
- ▶ Only use genuine spare parts!
- ▶ Refer to the spare parts catalogue when ordering spare parts.
- ▶ Always renew seals and O-rings removed during serviceing or repair work.

### After inspection/serviceing

- ▶ Retighten all loosened threaded fittings.
- ▶ Recommission the appliance (→ page 35).
- ▶ Check all connections for leaks.
- ▶ Check the gas-air ratio and adjust if necessary (→ page 50).

## 15.1 Checklist for inspection/serviceing (Inspection/Serviceing report)

Date				
1	Retrieve last fault stored on the Heatronic module, service function <b>6.A</b> (→ page 57).			
2	On Logamax plus GB042-22K appliances, check filter in cold water pipe (→ page 57).			
3	Perform a visual check of the air/flue gas routing.			
4	Check the gas supply pressure, (→ page 52).	mbar (kPa)		
5	Check the gas-air ratio at min./max. and adjust if necessary (→ page 50).	min. % max. %		
6	Check for leaks on the gas and water connections (→ page 32).			
7	Check heat exchanger, (→ page 59).			
8	Check burner (→ page 61).			
9	Check electrodes (→ page 57).			
10	Check diaphragm in mixer unit (→ page 62).			
11	Clean condensate trap (→ page 62).			
12	Check the expansion vessel pre-charge pressure matches the static head of the heating system.	bar (kPa)		
13	Check the heating system pressure.	bar (kPa)		
14	Check electrical wiring for damage.			
15	Check the heating controller settings.			
16	Check the selected service functions in accordance with the "Heatronic settings" label (→ Fig. 37, page 38)			

Table 22

## 15.2 Description of various servicing operations

### 15.2.1 Retrieving last fault stored (service function 6.A)

- ▶ Select service function **6.A** (→ page 43).



For an overview of faults, see page 67.

### 15.2.2 Checking electrodes

- ▶ Remove electrode set (→ page 10) and gasket. Check electrodes for dirt; clean or replace if required.
- ▶ Refit electrode set and check for tightness (Fig. 56).

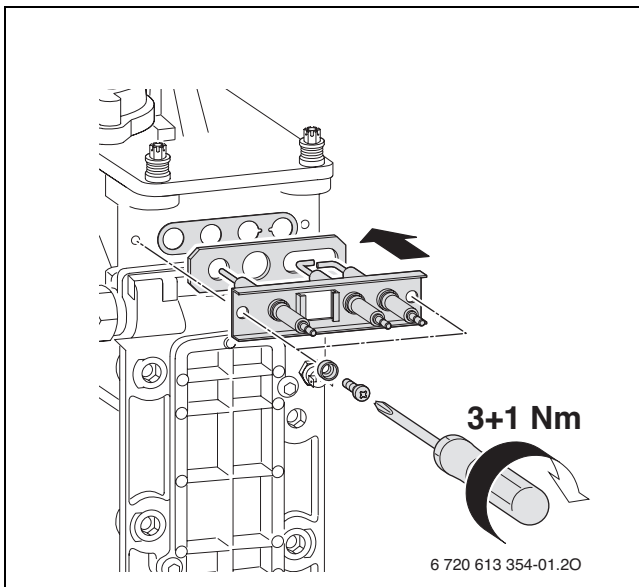

Fig. 55

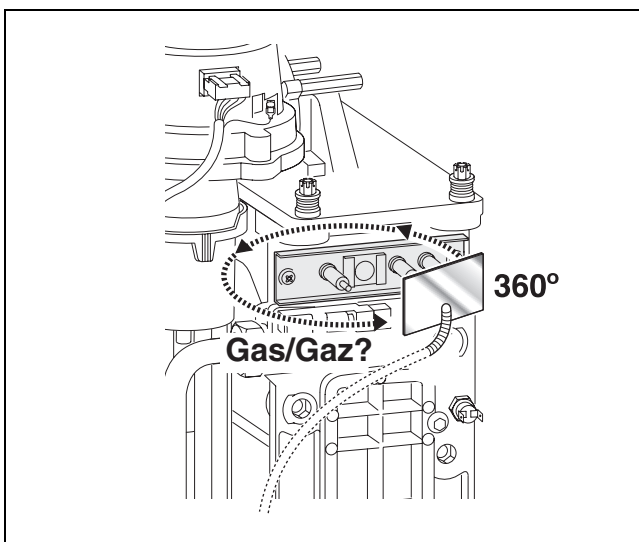

Fig. 56

### 15.2.3 Strainer in cold water pipe (ZWB)

- ▶ Undo cold water pipe and check filter for dirt.

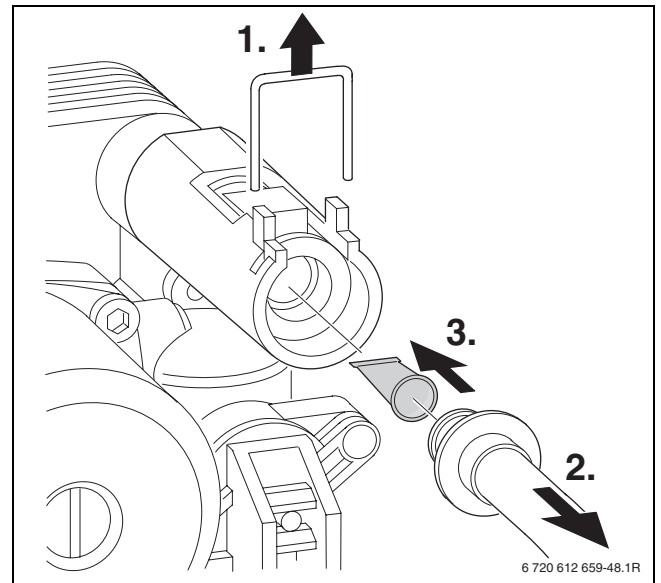

Fig. 57

### 15.2.4 Plate type heat exchanger (ZWB)

If the DHW output is insufficient:

- ▶ Check strainer in cold water pipe for dirt (→ page 57).
- ▶ Remove plate-type heat exchanger and replace -or-
- ▶ Descale only with a product that has been approved for stainless steel (1.4401).

Remove the plate heat exchanger:

- ▶ Disconnect electrical connectors.
- ▶ Remove hose from pressure relief valve.

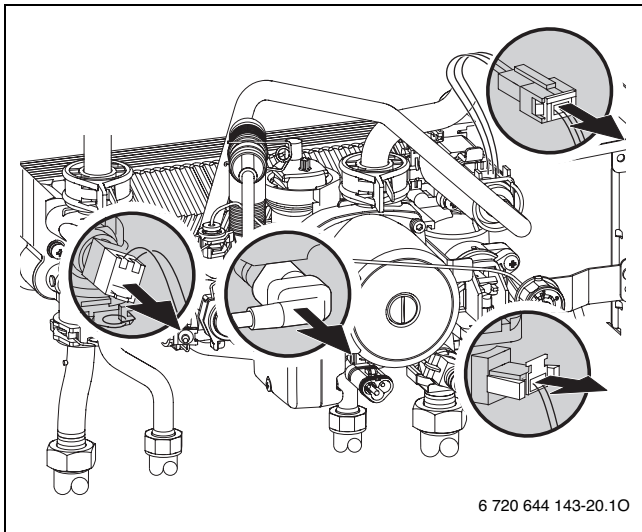

Fig. 58

- ▶ Undo/remove pipe unions.

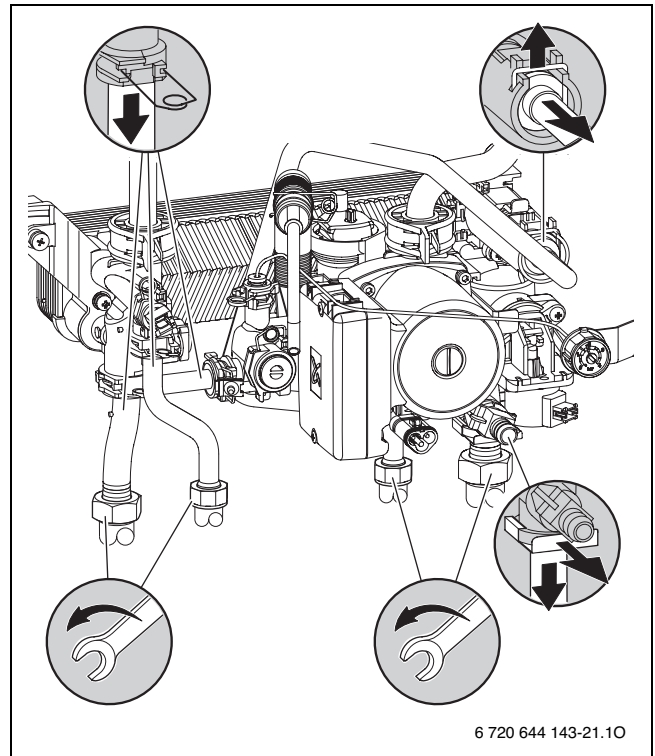

Fig. 59

- ▶ Undo the pressure gauge fastener.

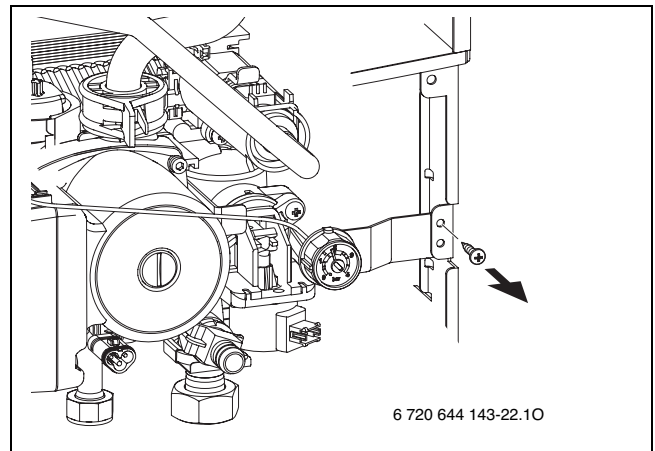

Fig. 60

- ▶ Release the quick-acting closures and remove the hydraulic assembly completely.

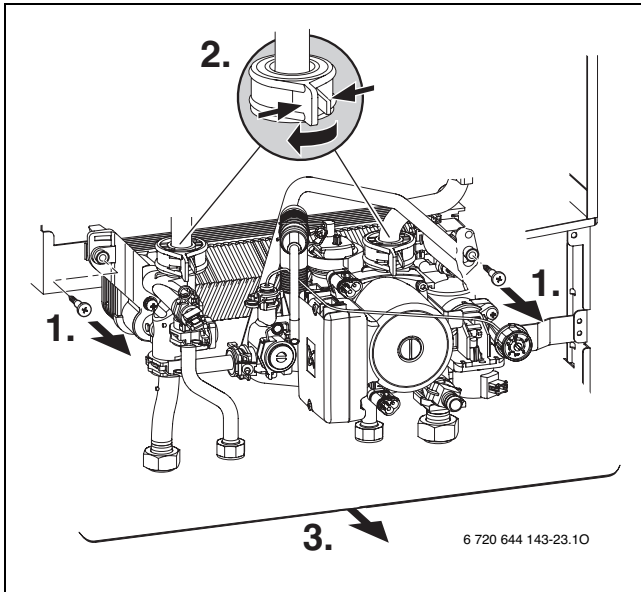

Fig. 61

- ▶ Undo the plate-type heat exchanger.

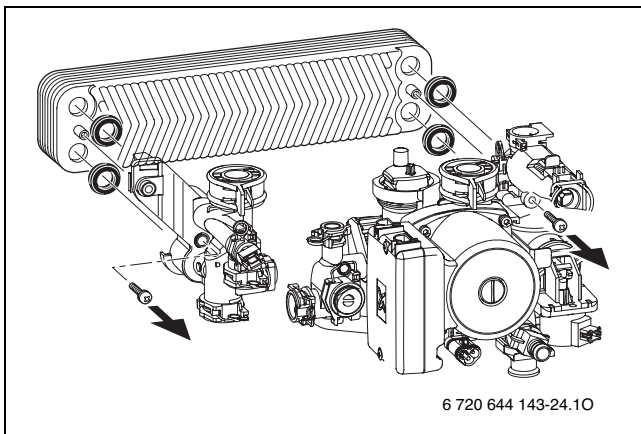

Fig. 62

- ▶ Fit new plate-type heat exchanger with new gaskets and reconnect the hydraulic assembly in reverse order.
- ▶ Check all connections for leaks.

### 15.2.5 Heat exchanger

For cleaning the heat exchanger, use brush, accessory no. 1060, and cleaning blade, accessory no. 1061.

- ▶ Check control pressure at maximum rated output at mixer unit.

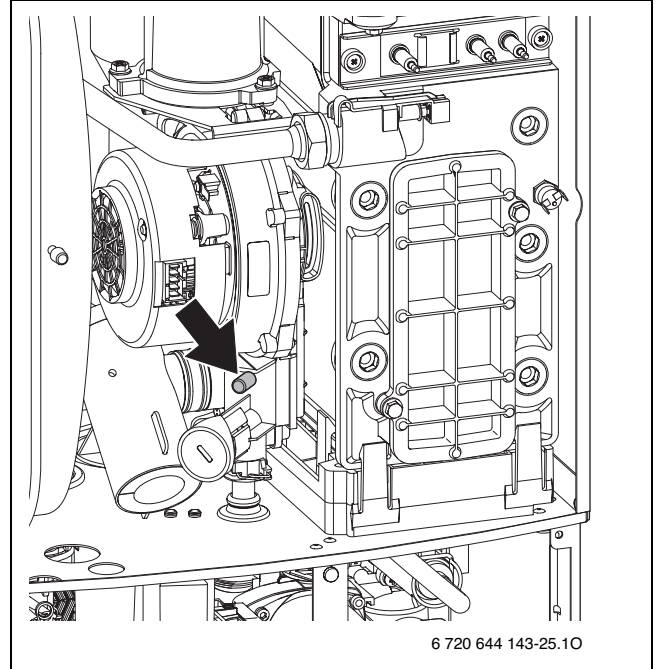

Fig. 63

Appliance	Control pressure	Cleaning required?
ZSB 30-2 A	≥ 3.9 mbar (0.39 kPa)	No
	< 3.9 mbar (0.39 kPa)	Yes
ZWB 37-2 A	≥ 3.9 mbar (0.39 kPa)	No
	< 3.9 mbar (0.39 kPa)	Yes

Table 23

If cleaning is required:

- ▶ Remove the heat exchanger access panel (→ page 10) and any panel behind, if installed.

- ▶ Remove the condensate siphon and place a suitable container below the condensate outlet.

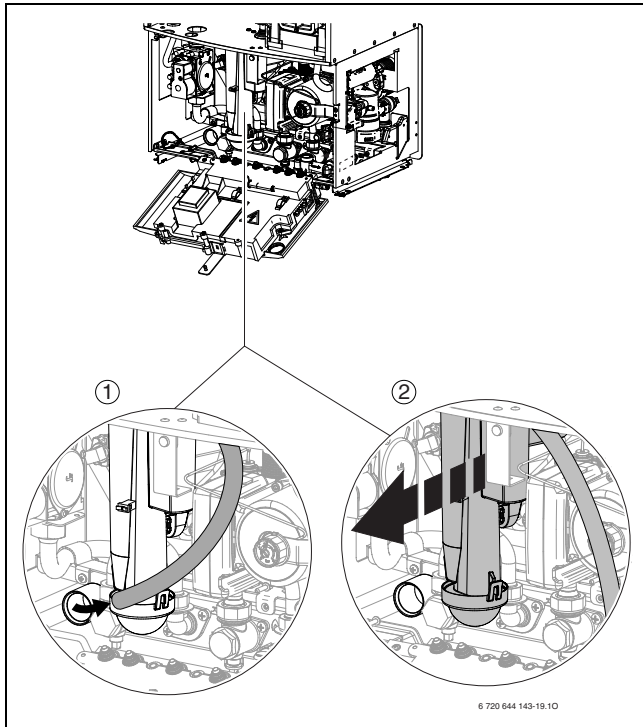

Fig. 64

- ▶ With the cleaning blade, clean the heat exchanger from the bottom to the top.

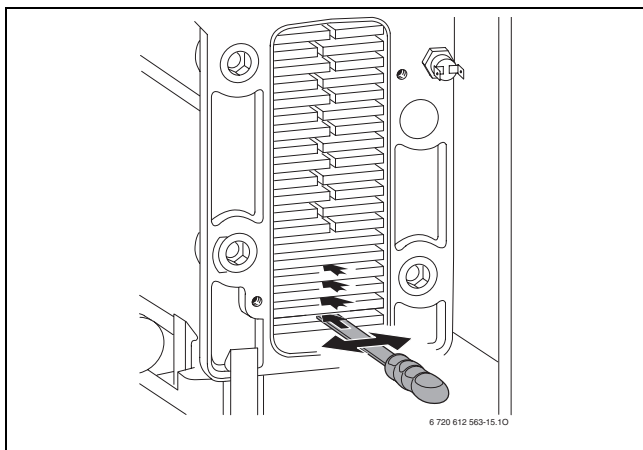

Fig. 65

- ▶ Clean the heat exchanger with the brush from top to bottom.

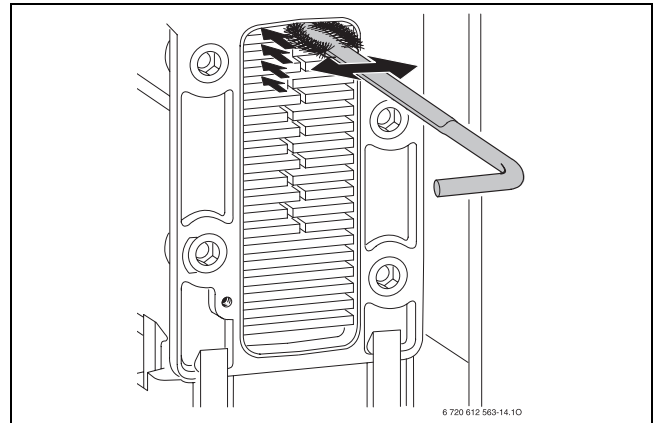

Fig. 66

- ▶ Remove burner (→ chapter 15.2.6 “Checking the burner”) and flush the heat exchanger with water from above.

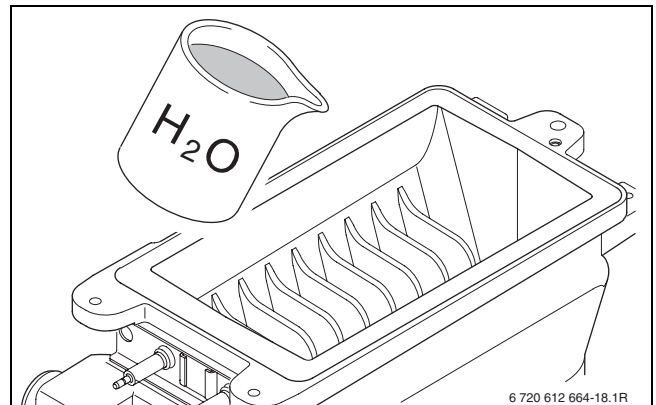

Fig. 67

- ▶ Clean the condensate tray (with reversed brush) and the siphon connection.

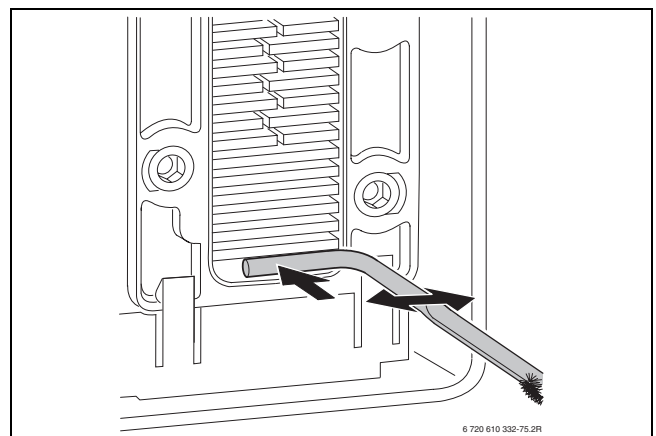

Fig. 68

- ▶ Close the heat exchanger access panel using a new gasket and tighten the screws to approx. 5 Nm.

### 15.2.6 Burner

- ▶ Remove two screws [2] from top cover [1] and lift off cover (→ Fig. 69).

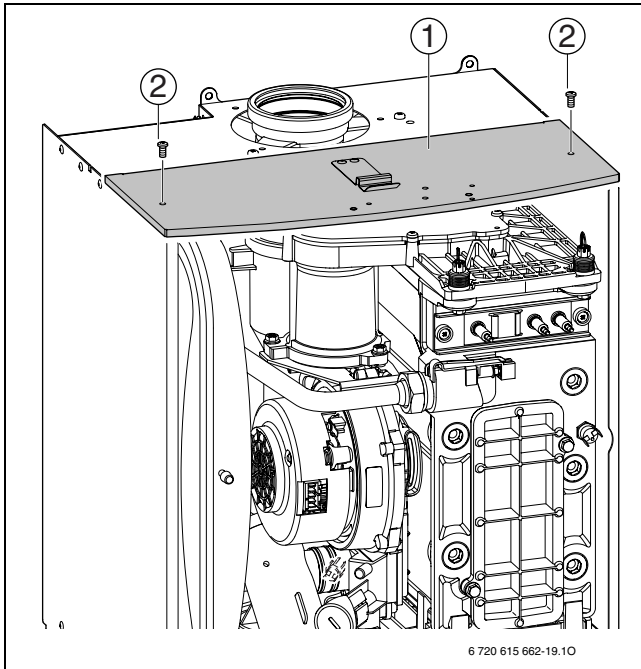

Fig. 69

- ▶ Remove clips [3], nuts [4] and [5] and two screws [7] (→ Fig. 69).

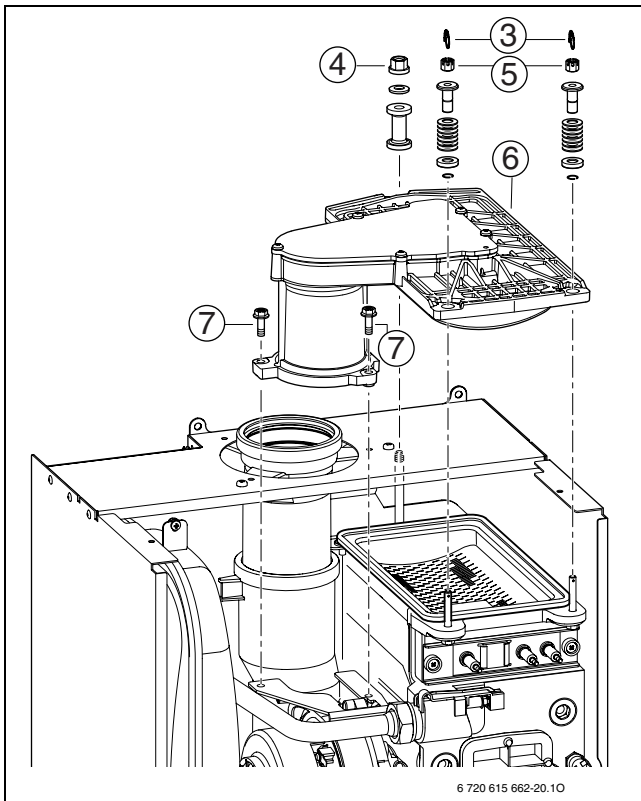

Fig. 70

- ▶ Remove burner cover [6].

- ▶ Remove burner and clean its components.

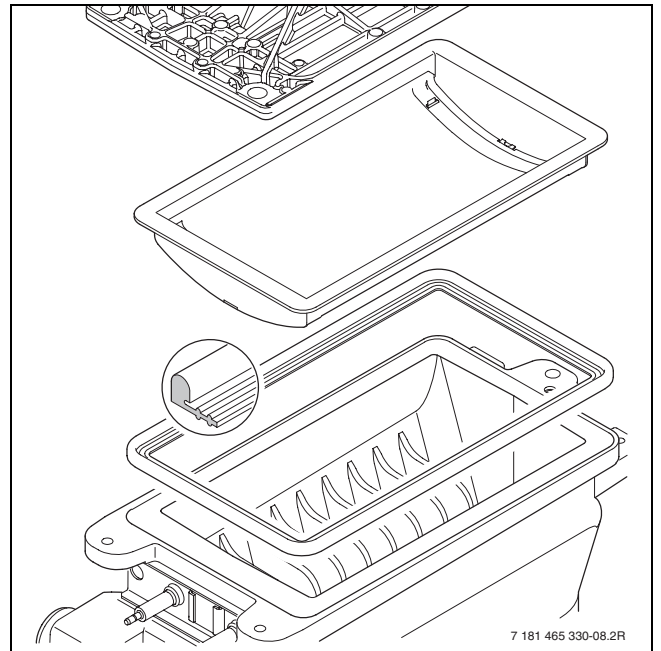

Fig. 71

- ▶ Refit burner, possibly with a new gasket, in reverse order.
- ▶ Adjust the gas-air ratio (→ page 50).

### 15.2.7 Diaphragm in mixer unit



**CAUTION:** Ensure that the diaphragm is not damaged during its release and refitting!

- ▶ Open the mixing chamber.
- ▶ Carefully withdraw diaphragm from fan intake tube and check for soiling and splits.

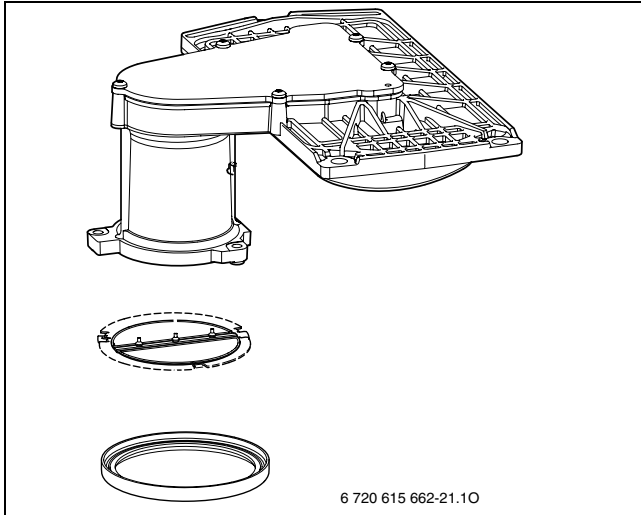

Fig. 72

- ▶ Carefully refit the diaphragm into the fan connector, in the correct position.



The diaphragm flaps must open upwards.

- ▶ Close the mixing chamber.

### 15.2.8 Cleaning condensate trap

- ▶ Remove condensate trap and check that the heat exchanger connection is clear.

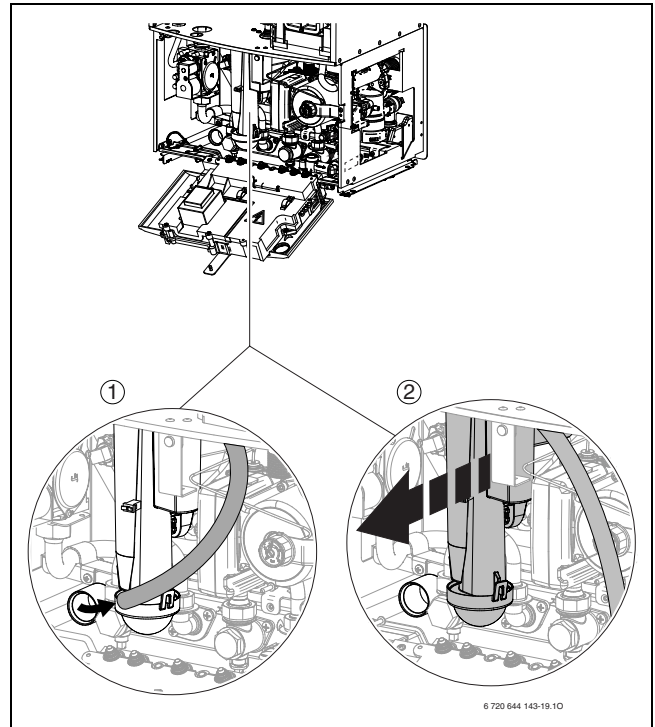

Fig. 73

- ▶ Remove and clean the condensate siphon sump.
- ▶ Check condensate hose and clean if necessary.
- ▶ Fill condensation trap with approx. 1/4 l of water and refit.

### 15.2.9 Checking the expansion vessel (see also page 25)

The expansion vessel should be checked annually.

- ▶ Depressurise the appliance.
- ▶ If necessary, adjust charge pre-charge pressure of expansion vessel to the static head of the heating system.

### 15.2.10 Setting the heating system pressure



**NOTE:** Risk of damaging the appliance.

- ▶ Only top up the heating system when the appliance is cold.

Pressure gauge reading	
1 bar (100 kPa)	Minimum system pressure (when cold)
1 - 2 bar (100 - 200 kPa)	Optimum system pressure
3 bar (300 kPa)	Maximum system pressure at highest heating water temperature: must not be exceeded (otherwise pressure relief valve opens).

Table 24

- ▶ If the gauge is below 1 bar (100 kPa) (when the system is cold), top up the system water between 1 and 2 bar (100 kPa and 200 kPa).
- ▶ If there is a pressure drop: check the expansion vessel and heating system for leaks.

### 15.2.11 Checking electrical wiring

- ▶ Check electrical wiring for physical damage and replace faulty leads.

## 16 Displays

The display shows the following (table 25 and 26):

Value displayed	Description	Range
Number or letter, dot followed by letter	Service function (→table 15/ 16, page 44)	
Letter followed by number or letter	Fault code flashes (→ table 27, page 67)	
Two numbers	Decimal figure, e.g. flow temperature	00..99
U followed by 0..9	Decimal figure;100..109 is displayed as U 0..U9	0..109
One number (displayed for longer) followed twice by two numbers (displayed briefly)	Decimal figure (three digits); first digit is shown alternating with the two last digits (e.g. 1...69..69 for 169)	0..999
Two dashes followed by two pairs of numbers	Boiler coding card number;  Value is shown in three stages: 1. Two dashes 2. First two numbers 3. Last two numbers (e.g.: -- ..10..04)	1000 ... 9999
Two letters followed by two pairs of numbers	Version number;  Value is shown in three stages: 1. First two letters 2. First two numbers 3. Last two numbers (e.g.: CF 10 20)	

Table 25 Displays

Special display	Description
	Acknowledge by pressing any key (except reset).
	Acknowledge by pressing two keys simultaneously
	Acknowledge by pressing  and holding for more than 3 seconds (Save function).
	The display alternately shows the flow temperature and . The appliance operates for 15 minutes at the minimum rated output.
	The display shows the flow temperature alternating with . The appliance works with the set maximum rated output in heating mode, →service function <b>1.A.</b>
	The display alternately shows the flow temperature and . The appliance operates for 15 minutes at the maximum rated output.
	Ventilation function is enabled, see service function <b>2.C.</b>
	The display shows the flow temperature alternating with . The trap filling program is enabled, →service function <b>4.F.</b>
	The display shows the flow temperature alternating with : the set inspection interval has elapsed, →service function <b>5.A.</b>
	The display alternately shows the flow temperature and . The heating circuit pump is blocked.
	The display shows the flow temperature alternating with . The temperature gradient limiter is enabled. Excessive flow temperature increase: heating mode is suspended for two minutes.

Table 26 Special displays

Special display	Description
	Screed drying function of the weather-compensated controller (→operating instructions) or building drying function (→service function <b>7.E</b> ) operational.

Table 26 Special displays

## 17 Fault mode

### 17.1 Troubleshooting



**DANGER:** Risk of explosion!

- ▶ Turn off gas valve before working on gas-carrying components.
- ▶ Check for leaks before working on gas-carrying components.



**DANGER:** Risk of poisoning!

- ▶ Check for leaks before working on gas-carrying components.



**DANGER:** Risk of electric shock!

- ▶ Before carrying out work on electrical components, disconnect the power supply (230 V AC) (fuse, circuit breaker) and secure against unintentional reconnection.



**WARNING:** Risk of scalding!

Hot water can cause severe scalding

- ▶ Drain the appliance before working on components that carry water.



**NOTE:** Leaking water may damage the Heatronic module.

- ▶ Cover the Heatronic module before working on any parts that carry water.

All safety, modulation and control components are monitored by the Heatronic system.

If a fault occurs during operation, a warning tone sounds.



If you press a button, the warning tone stops.

The display indicates a fault (e. g. ) and the reset-button may also flash.

If the reset button flashes:

- ▶ Press and hold the reset button until the display shows .
- The appliance will start up again and the flow temperature will be displayed.

If the reset button does not flash:

- ▶ Switch the appliance off and then on again at the main switch.
- The appliance will start up again and the central heating flow temperature will be displayed.



For an overview of faults, see page 67.

For an overview of displays, see page 64.

If a fault persists:

- ▶ Check PCB, replace if required and set service functions as per "Heatronic settings" label (→ Fig. 37, page 38).

## 17.2 Faults that are shown on the display

Display code	Description	Remedy
<b>A7</b>	Temperature sensor for hot water is faulty. (ZWB)	<ul style="list-style-type: none"> <li>▶ Check temperature sensor and lead for breaks or short circuits, and replace if required.</li> <li>▶ Plug in boiler coding card correctly; replace if required.</li> </ul>
<b>A8</b>	Communication fault.	<ul style="list-style-type: none"> <li>▶ Check BUS device connecting lead.</li> <li>▶ Check controller, replace if required.</li> </ul>
<b>Ad</b>	Cylinder temperature sensor not detected.  The cylinder temperature sensor was recognised as a BUS subscriber and then reconnected to the appropriate terminal.	<ul style="list-style-type: none"> <li>▶ Check cylinder temperature sensor and connecting lead.</li> <li>▶ Resetting the Heatronic 3 to its standard settings (→ service function 8.E, page 49), resetting the IPM 1 or IPM 2 to its standard settings and carrying out the automatic system configuration on the heating controller.</li> </ul>
<b>b1</b>	Code plug not detected.	<ul style="list-style-type: none"> <li>▶ Plug in boiler coding card correctly; replace if required.</li> </ul>
<b>b2/b3/ b4/b5/ b6</b>	Internal data error.	<ul style="list-style-type: none"> <li>▶ Restore Heatronic 3 to standard settings (→service function 8.E).</li> </ul>
<b>C6</b>	Fan not running.	<ul style="list-style-type: none"> <li>▶ Check fan lead and connector, check fan, replace as necessary.</li> </ul>
<b>CC</b>	Outside temperature sensor not detected.	<ul style="list-style-type: none"> <li>▶ Check outside temperature sensor and connecting lead for breaks.</li> <li>▶ Correctly connect outside temperature sensor to terminals A and F.</li> </ul>
<b>d3</b>	External temperature limiter faulty.  External limiter has tripped.  Temperature limiter locked out.	<ul style="list-style-type: none"> <li>▶ Check temperature limiter and lead for breaks or short circuits, and replace if required.</li> <li>▶ Temperature limiter has tripped. Jumper across 8-9 or PR-P0 is missing.</li> <li>▶ Reset the temperature limiter.</li> </ul>
<b>d5</b>	External flow temperature sensor defective (flow equaliser).  The external flow temperature sensor was recognised as a BUS subscriber and then reconnected to the appropriate terminal.	<ul style="list-style-type: none"> <li>▶ Check temperature sensor and lead for breaks or short circuits, and replace if required.</li> <li>▶ Check whether only one temperature sensor is connected; otherwise remove second temperature sensor.</li> <li>▶ Resetting the Heatronic 3 to its standard settings (→ Service function 8.E: Reset all parameters), resetting the IPM 1 or IPM2 to its standard settings and carrying out the automatic system configuration on the heating controller.</li> </ul>
<b>E2</b>	Temperature sensor in CH flow faulty.	<ul style="list-style-type: none"> <li>▶ Check temperature sensor and lead for breaks or short circuits, and replace if required.</li> </ul>

Table 27 Faults shown on the display

Display code	Description	Remedy
<b>E9</b>	Heat exchanger temperature limiter or flue gas temperature limiter has tripped.	<ul style="list-style-type: none"> <li>▶ Check heat exchanger temperature limiter and lead for breaks or short circuits; replace if required.</li> <li>▶ Check flue gas temperature limiter and lead for breaks or short circuits; replace if required.</li> <li>▶ Check the operating pressure of the heating system.</li> <li>▶ Check temperature limiter; replace if required.</li> <li>▶ Check pump starter; replace pump if required.</li> <li>▶ Check PCB fuse; replace if required.</li> <li>▶ Vent appliance.</li> <li>▶ Check heat exchanger on the water side; replace if required.</li> <li>▶ On appliances with displacement bodies in heat exchanger, check whether displacement bodies are fitted.</li> </ul>
<b>EA</b>	Flame not detected.	<ul style="list-style-type: none"> <li>▶ Check earth lead is correctly connected.</li> <li>▶ Check whether gas valve is open.</li> <li>▶ Check gas supply pressure; correct if required.</li> <li>▶ Check power supply.</li> <li>▶ Check electrodes with lead; replace if required.</li> <li>▶ Check flue gas system; clean or repair if required.</li> <li>▶ Check gas/air ratio; correct if required.</li> <li>▶ For natural gas: Check external gas flow limiter; replace if required.</li> <li>▶ For open flue operation, check air supply or ventilation apertures.</li> <li>▶ Clean out condensation trap discharge pipe.</li> <li>▶ Remove diaphragm from fan inlet connection and check for contamination or tears.</li> <li>▶ Clean heat exchanger.</li> <li>▶ Check gas valve; replace if required.</li> <li>▶ Plug in boiler coding card correctly; replace if required.</li> <li>▶ Two-phase network (IT): 2 M <math>\Omega</math> - insert resistance between PE and N at PCB power supply.</li> </ul>
<b>F0</b>	Internal fault.	<ul style="list-style-type: none"> <li>▶ Press reset for 3 seconds and release. When the button is released, the appliance will restart.</li> <li>▶ Check electrical plug-in contacts and ignition leads; replace PCB if required.</li> <li>▶ Check gas/air ratio; correct if required.</li> </ul>
<b>F1</b>	Internal data error.	<ul style="list-style-type: none"> <li>▶ Restore Heatronic 3 to standard settings (→service function 8.E).</li> </ul>
<b>F7</b>	A flame is detected although the appliance is switched off.	<ul style="list-style-type: none"> <li>▶ Check electrodes; replace if required.</li> <li>▶ Check flue gas system; clean or repair if required.</li> <li>▶ Check PCB for moisture; dry if required.</li> </ul>

Table 27 Faults shown on the display

Display code	Description	Remedy
<b>FA</b>	A flame is detected after the gas has been switched off.	<ul style="list-style-type: none"> <li>▶ Check gas valve; replace if required.</li> <li>▶ Clean condensate trap.</li> <li>▶ Check electrodes and lead; replace if required.</li> <li>▶ Check flue gas system; clean or repair if required.</li> </ul>
<b>Fd</b>	Reset was pressed in error.	<ul style="list-style-type: none"> <li>▶ Press reset again.</li> <li>▶ Check cable harness to high limit safety cut-out and gas valve for earth connection.</li> </ul>

Table 27 Faults shown on the display

### 17.3 Faults that are not shown on the display

Appliance faults	Remedy
Combustion noise too loud; rumbling noises	<ul style="list-style-type: none"> <li>▶ Plug in boiler coding card correctly; replace if required.</li> <li>▶ Check gas type.</li> <li>▶ Check gas supply pressure; adjust if required.</li> <li>▶ Check flue gas system; clean or repair if required.</li> <li>▶ Check gas/air ratio in the combustion air and flue gas; replace gas valve if required.</li> </ul>
Flow noises	<ul style="list-style-type: none"> <li>▶ Set pump stages or pump characteristic maps correctly and match to maximum output.</li> <li>▶ Set pump mode correctly.</li> </ul>
Heat-up takes too long	<ul style="list-style-type: none"> <li>▶ Set pump stages or pump characteristic maps correctly and match to maximum output.</li> <li>▶ Set pump mode correctly.</li> </ul>
Flue gas readings incorrect; CO levels too high	<ul style="list-style-type: none"> <li>▶ Check gas type.</li> <li>▶ Check gas supply pressure; adjust if required.</li> <li>▶ Check flue gas system; clean or repair if required.</li> <li>▶ Check gas/air ratio in flue gas; replace gas valve if required.</li> </ul>
Ignition too harsh, poor	<ul style="list-style-type: none"> <li>▶ Check gas type.</li> <li>▶ Check gas supply pressure; adjust if required.</li> <li>▶ Check power supply.</li> <li>▶ Check electrodes with lead; replace if required.</li> <li>▶ Check flue gas system; clean or repair if required.</li> <li>▶ Check gas/air ratio; replace gas valve if required.</li> <li>▶ For natural gas: Check external gas flow limiter; replace if required.</li> <li>▶ Check burner; replace if required.</li> </ul>
Set flow temperature (e.g. of the FW-100 controller) exceeded	<ul style="list-style-type: none"> <li>▶ Switch OFF automatic cycle block, i.e. set value to 0.</li> <li>▶ Set the required cycle block, e.g. standard setting of 3 minutes.</li> </ul>
Condensate in air box	<ul style="list-style-type: none"> <li>▶ Insert diaphragm in the mixing facility as per installation instructions; replace if required.</li> </ul>
DHW temperature is not reached (ZWB)	<ul style="list-style-type: none"> <li>▶ Plug in boiler coding card correctly; replace if required.</li> <li>▶ Check turbine; replace if required.</li> </ul>
Heatronic is flashing (i.e. all keys, all display segments, burner indicator etc. are flashing)	<ul style="list-style-type: none"> <li>▶ Replace fuse Si 3 (24 V).</li> </ul>
Set room temperature not reached	<ul style="list-style-type: none"> <li>▶ De-aerate the hydronic system.</li> <li>▶ Check the thermostatic radiator valves</li> <li>▶ Check the demand from the controller</li> <li>▶ Complete air purge (service function 2.C).</li> </ul>

Table 28 Faults not shown on the display

## 17.4 Sensor values

### 17.4.1 Outside temperature sensor (for weather-compensated controllers, accessory)

Outside temperature / °C Testing tolerance ± 10%	Resistance (Ω)
-20	2 392
-16	2 088
-12	1 811
-8	1 562
-4	1 342
0	1 149
4	984
8	842
10	781
15	642
20	528
25	436

Table 29

### 17.4.2 Flow and DHW sensors

Temperature/ °C Measuring tolerance ± 10 %	Resistance (k Ω)
20	14 772
25	11 981
30	9 786
35	8 047
40	6 653
45	5 523
50	4 608
55	3 856
60	3 243
65	2 744
70	2 332
75	1 990
80	1 704
85	1 464
90	1 262
95	1 093
100	950

Table 30

### 17.5 Settings for heating output with ZSB 30 ...23

NG			
Gross calorific value (MJ/m <sup>3</sup> ) (15 °C): 37.8			
Net calorific value (MJ/m <sup>3</sup> ) (15 °C): 34.0			
Display	Heat output (kW)	Gas consumption (MJ/m <sup>3</sup> )	Gas flow rate <sup>1)</sup> (l/min)
32	7.7	31.9	14
33	8.0	33.2	15
36	9.0	37.3	16
39	10.0	41.4	18
42	11.0	45.5	20
45	12.0	49.6	22
48	13.0	53.7	24
51	14.0	57.8	25
54	15.0	61.9	27
57	16.0	66.0	29
60	17.0	70.1	31
63	18.0	74.2	33
66	19.0	78.3	34
69	20.0	82.4	36
73	21.0	86.5	38
76	22.0	90.6	40
79	23.0	94.7	42
82	24.0	98.8	43
85	25.0	102.9	45
88	26.0	107.0	47
91	27.0	111.1	49
94	28.0	115.2	51
97	29.0	119.3	52
<b>U0 (100)</b>	30.0	123.4	54

Table 31

1) Gas flow rate (l/min at t<sub>v</sub>/t<sub>R</sub> = 80/60 °C)

### 17.6 Settings for heating output with ZSB 30 ...31

Display	Propane		Butane	
	Heat output (kW)	Gas consumption (MJ/m <sup>3</sup> )	Heat output (kW)	Gas consumption (MJ/m <sup>3</sup> )
43	11.0	45.9	12.5	52.2
46	12.0	50.0	13.6	56.8
49	13.0	54.1	14.8	61.5
52	14.0	58.1	15.9	66.1
55	15.0	62.2	17.0	70.7
58	16.0	66.3	18.2	75.4
61	17.0	70.4	19.3	80.0
64	18.0	74.5	20.5	84.6
67	19.0	78.5	21.6	89.3
70	20.0	82.6	22.7	93.9
73	21.0	86.7	23.9	98.5
76	22.0	90.8	25.0	103.2
79	23.0	94.8	26.1	107.8
82	24.0	98.9	27.3	112.4
85	25.0	103.0	28.4	117.1
88	26.0	107.1	29.5	121.7
91	27.0	111.1	30.7	126.3
94	28.0	115.2	31.8	131.0
97	29.0	119.3	33.0	135.6
<b>U0 (100)</b>	30.0	123.4	34.1	140.2

Table 32

### 17.7 Settings for heating output with ZWB 37 ...23

NG			
Gross calorific value (MJ/m <sup>3</sup> ) (15 °C): 37.8			
Net calorific value (MJ/m <sup>3</sup> ) (15 °C): 34.0			
Display	Heat output (kW)	Gas consumption (MJ/m <sup>3</sup> )	Gas flow rate <sup>1)</sup> (l/min)
32	9.4	31.9	17
34	10.0	41.6	18
36	11.0	45.7	20
39	12.0	49.8	22
41	13.0	53.9	24
44	14.0	57.9	26
46	15.0	62.0	27
49	16.0	66.1	29
51	17.0	70.2	31
54	18.0	74.3	33
56	19.0	78.4	35
59	20.0	82.5	36
61	21.0	86.6	38
64	22.0	90.7	40
66	23.0	94.7	42
69	24.0	98.8	44
71	25.0	102.9	45
74	26.0	107.0	47
76	27.0	111.1	49
79	28.0	115.2	51
81	29.0	119.3	53
84	30.0	123.4	54

Table 33

1) Gas flow rate (l/min at t<sub>V</sub>/t<sub>R</sub> = 80/60 °C

### 17.8 Settings for heating output with ZWB 37 ...31

Display	Propane		Butane	
	Heat output (kW)	Gas consumption (MJ/m <sup>3</sup> )	Heat output (kW)	Gas consumption (MJ/m <sup>3</sup> )
45	13.9	57.9	15.8	65.8
45	14.0	58.3	15.9	66.3
47	15.0	62.4	17.0	70.9
50	16.0	66.4	18.2	75.5
52	17.0	70.5	19.3	80.1
55	18.0	74.6	20.5	84.7
57	19.0	78.6	21.6	89.4
60	20.0	82.7	22.7	94.0
62	21.0	86.8	23.9	98.6
65	22.0	90.8	25.0	103.2
67	23.0	94.9	26.1	107.9
70	24.0	99.0	27.3	112.5
72	25.0	103.0	28.4	117.1
75	26.0	107.1	29.5	121.7
77	27.0	111.2	30.7	126.3
80	28.0	115.2	31.8	131.0
82	29.0	119.3	33.0	135.6
85	30.0	123.4	34.1	140.2

Table 34

## 18 Commissioning report for the appliance

<b>Customer/system user:</b>	
Surname, first name	Street, house number
Telephone/fax	Postcode, town
<b>System installer:</b>	
Order number:	
Appliance type: <b>(Complete a separate report for every appliance!)</b>	
Serial number:	
Date commissioned:	
<input type="checkbox"/> Individual appliance   <input type="checkbox"/> Cascade, number of appliances: .....	
Installation room: <input type="checkbox"/> Cellar   <input type="checkbox"/> Attic   Other:	
Ventilation apertures: Number: ....., size: approx. <span style="float: right;">cm<sup>2</sup></span>	
Flue routing: <input type="checkbox"/> Twin pipe system   <input type="checkbox"/> LAS   <input type="checkbox"/> Duct   <input type="checkbox"/> Separate pipe routing	
<input type="checkbox"/> Plastic   <input type="checkbox"/> Aluminium   <input type="checkbox"/> Stainless steel	
Total length: approx. .... m   90° bend: ..... pce   15 - 45° bend: ..... pce	
Flue tightness test (with combustion air flowing in countercurrent): <input type="checkbox"/> yes   <input type="checkbox"/> no	
CO <sub>2</sub> value in the combustion air at maximum rated output: <span style="float: right;">%</span>	
O <sub>2</sub> value in the combustion air at maximum rated output: <span style="float: right;">%</span>	
Notes regarding underpressure or overpressure operation:	
<b>Gas setting and flue gas test:</b>	
Selected gas type: <input type="checkbox"/> Natural gas   <input type="checkbox"/> Propane   <input type="checkbox"/> Butane   <input type="checkbox"/> U-LPG	
Gas supply pressure: <span style="float: right;">kPa</span>	Gas static supply pressure: <span style="float: right;">mbar</span>
Selected maximum rated output: <span style="float: right;">kW</span>	Selected minimum rated output: <span style="float: right;">kW</span>
Gas flow rate at maximum rated output: <span style="float: right;">ltr/min</span>	Gas flow rate at minimum rated output: <span style="float: right;">ltr/min</span>
Net calorific value H <sub>1B</sub> : <span style="float: right;">kWh/m<sup>3</sup></span>	
CO <sub>2</sub> at maximum rated output: <span style="float: right;">%</span>	CO <sub>2</sub> at minimum rated output: <span style="float: right;">%</span>
O <sub>2</sub> at maximum rated output: <span style="float: right;">%</span>	O <sub>2</sub> at minimum rated output: <span style="float: right;">%</span>
CO at maximum rated output: <span style="float: right;">ppm</span>	CO at minimum rated output: <span style="float: right;">ppm</span>
Flue gas temperature at maximum rated output: <span style="float: right;">°C</span>	Flue gas temperature at minimum rated output: <span style="float: right;">°C</span>
Maximum measured flow temperature: <span style="float: right;">°C</span>	Minimum measured flow temperature: <span style="float: right;">°C</span>
<b>System hydraulics:</b>	
<input type="checkbox"/> Low loss header, type:	<input type="checkbox"/> Additional expansion vessel Size/pre-charge pressure: Automatic air vent valve installed? <input type="checkbox"/> yes   <input type="checkbox"/> no
<input type="checkbox"/> Heating circuit pump:	
<input type="checkbox"/> DHW cylinder/type/number/heating surface output:	
<input type="checkbox"/> System hydraulics checked, notes:	

<b>Modified service functions:</b> (Select the modified service functions and enter the values here.)	
Example: service function 7.d changed from 00 to 01	
"Heatronic settings" label filled out and affixed <input type="checkbox"/>	
<b>Heating control unit:</b>	
<input type="checkbox"/> FW 100   <input type="checkbox"/> FW 200   <input type="checkbox"/> FW 500   <input type="checkbox"/> FR 110	<input type="checkbox"/> TA 250   <input type="checkbox"/> TA 270   <input type="checkbox"/> TA 300
<input type="checkbox"/> FB 10 × ..... pce, heating circuit code(s):	
<input type="checkbox"/> FB 100 × ..... pce, heating circuit code(s):	
<input type="checkbox"/> FR 10 × ..... pce, heating circuit code(s):	
<input type="checkbox"/> FR 100 × ..... pce, heating circuit code(s):	
<input type="checkbox"/> ISM 1   <input type="checkbox"/> ISM 2	<input type="checkbox"/> ICM × ..... pce   <input type="checkbox"/> IEM   <input type="checkbox"/> IGM   <input type="checkbox"/> IUM
<input type="checkbox"/> IPM 1 × ..... pce., heating circuit(s) coding:	
<input type="checkbox"/> IPM 2 × ..... pce., heating circuit(s) coding:	
Miscellaneous:	
<input type="checkbox"/> Heating control unit set, notes:	
<input type="checkbox"/> Modified heating control unit settings documented in the controller operating/installation instructions	
<b>The following work has been carried out:</b>	
<input type="checkbox"/> Electrical connections checked, notes:	
<input type="checkbox"/> Condensate trap filled	<input type="checkbox"/> Combustion air/flue gas test carried out
<input type="checkbox"/> Function check carried out	<input type="checkbox"/> Was a tightness test carried out on the gas and water sides?
Commissioning includes checking the settings, a visual boiler tightness test and a function check of the boiler and control unit. The system installer conducts a test of the heating system.	
If, in the course of commissioning, any small installation faults in Bosch components are noticed, Bosch is always willing to remedy these installation faults after release by the customer. This does not imply any liability for the installation performance.	
The system named above has been checked to the extent described.	The documents have been handed over to the user. The user has been made aware of the safety information and operation of the above-mentioned heat source, including accessories. Attention has been drawn to the requirement for regular servicing of the above-mentioned heating system.
_____	_____
Name of service engineer	Date, user's signature
_____	<b>Affix the test report here.</b>
Date, system installer's signature	

# Index

- A**
- Anti-freeze ..... 24
  - Appliance
    - Switching off ..... 36
  - Appliance commissioning report ..... 74
  - Appliance details
    - Specification
      - ZSB 30-2 ..... 16
      - ZWB 37-2 ..... 17
  - Appliance layout ..... 10
- B**
- Before commissioning
    - Venting the system ..... 36
- C**
- Call up last fault saved ..... 48
  - Calling up the most recently saved fault ..... 48
  - Central heating
    - Switching on ..... 37
  - Checking gas supply pipe ..... 32
  - Checking the connections
    - Gas and water connections ..... 32
  - Checking the gas supply pressure ..... 52
  - Checking the size of the expansion vessel ..... 25
  - Checklist for inspection/maintenance ..... 56
  - Checks by local safety inspector
    - Flue system leakage check ..... 53
  - Combustion air ..... 25
  - Comfort mode ..... 38–39
  - Commissioning ..... 35
  - Condensate trap ..... 62
  - Connect, DHW cylinder ..... 34
  - Connecting the DHW cylinder ..... 34
  - Converting the appliance to different gas types ..... 50
  - Corrosion inhibitor ..... 24
- D**
- Description of appliance ..... 8
  - Description of various inspection/maintenance operations ..... 57
    - Checking the expansion vessel ..... 62
  - Details of appliance
    - Appliance layout ..... 10
    - Dimensions ..... 9
  - Dimensions ..... 9
  - Display of faults ..... 40, 66
  - disposal ..... 54
- E**
- Eco button ..... 38–39
  - Economy mode ..... 38–39
  - Electrical connections ..... 33
    - Checking electrical wiring ..... 63
    - Connecting accessories ..... 33
    - Heating controller, remote control units ..... 34
    - Temperature limiter ..... 34
  - Electrical wiring
    - DHW cylinder ..... 34
    - Environmental protection ..... 54
    - Expansion vessel ..... 62
      - Checking the size ..... 25
    - Explanation of model code ..... 7
- F**
- Fault mode ..... 40, 66
  - Faults ..... 67
  - Faults that are not shown on the display ..... 70
  - Faults that are shown on the display ..... 67
  - Fitting the appliance ..... 28
  - Flue gas testing ..... 53
  - Flue system leakage check ..... 53
  - Frost protection ..... 39
  - Fuses
    - Mains fuse ..... 33
- G**
- Gas and water connections ..... 32
  - Gas type ..... 50
  - Gas-air ratio ..... 50
- H**
- Heating system pressure ..... 63
  - Heatronic
    - Service functions ..... 43, 45–49, 57
- I**
- Important notes for installation ..... 24, 55
  - Important notes on inspection/maintenance ..... 55
  - Inspection and maintenance operations
    - Cleaning condensate trap ..... 62
  - Inspection and maintenance steps
    - Plate heat exchanger ..... 58
  - Inspection and servicing operations
    - Checking electrical wiring ..... 63
  - Inspection/Maintenance ..... 55
    - Checking electrodes ..... 57
  - Inspection/Maintenance log ..... 56
  - Installation ..... 24
    - Important notes ..... 24, 55
    - pre-fitting piping ..... 26
    - Siting the appliance ..... 25
  - Installation Site
    - Combustion air ..... 25
    - Surface temperature ..... 25
  - Intended use ..... 7
- L**
- LPG ..... 25
- M**
- Maintenance operations
    - Setting the heating system pressure ..... 63
  - Minimum clearances ..... 9
  - Mono-lever taps ..... 25

<b>N</b>	
Natural gas.....	17, 50
<b>O</b>	
Open vented heating systems .....	24
Operating conditions.....	16, 18
Outlet siphon .....	29
<b>P</b>	
Packaging .....	54
Procedure for servicing and maintenance	
Retrieving last fault stored .....	57
Product details .....	7
Description of appliance .....	8
Explanation of model code.....	7
Standard package .....	6
Pump anti-seizing function.....	42
<b>R</b>	
Recycling .....	54
Regulations .....	19
Retrieving last fault stored.....	57
Room thermostat.....	24
<b>S</b>	
Safety instructions.....	5
Sealants.....	24
Service functions	
Coding card number (service function 8.b) .....	49
Current fan speed (service function 9.b) .....	49
Current heating output (service function 9.C) .....	49
Current turbine flow rate (service function 6.d) ...	48
Cycle block (Service function 3.b) .....	47
DHW output (ZSB appliances)	
(Service function 1.b) .....	45
exiting without saving.....	43
Fan run-on time (service function 5.b).....	48
GFA fault (service function 8.d) .....	49
GFA status (service function 8.C) .....	49
Last fault saved (service function 6.A).....	48
Last fault stored (service function 6.A).....	57
Maximum flow temperature	
(Service function 2.b) .....	46
Most recently saved fault (service function 6.A) ...	48
No function (service function 7.A).....	48
Output (service function 1.A) .....	45
Permanent ignition (service function 8.F) .....	49
Permanent operating mode (service function 9.A) .....	49
Pump characteristic map (service function 1.C) ...	45
Pump curve (service function 1.d) .....	46
Pump run-on time (heating) (service function 9.F) .....	49
Pump switching type for heating mode (service	
function 1.E) .....	46
Reset inspection (service function 5.A) .....	48
Restoring appliance (Heatronic 3) to standard	
settings (service function 8.E) .....	49
Siphon filling program (service function 4.F) .....	48
Software version (service function 8.A) .....	49
Switching differential (service function 3.C) .....	47
Time switch input (service function 6.E).....	48
Turbine signal delay (only ZWB)	
(service function 9.E) .....	49
Venting function (Service function 2.C) .....	47
Setting the heating control unit.....	37
Setting the hot water temperature	
Appliances with hot water cylinder .....	38
Settings	
Heatronic .....	43
Settings for heating/DHW output	
ZSB 30...23.....	72–73
ZSB 30...31.....	72–73
Siting the appliance .....	25
Specification .....	16–17
Standard package .....	6
Steps for inspection and maintenance	
Call up last fault saved.....	48
Summer mode .....	39
Surface temperature .....	25
Switching off the appliance.....	36
Switching on the central heating .....	37
<b>T</b>	
Thermostatic mixer taps .....	25
Troubleshooting.....	66
<b>U</b>	
Underfloor heating .....	24
Used appliance .....	54
Used appliances .....	54
<b>V</b>	
Venting	
Venting function.....	47
Venting the system.....	36
<b>W</b>	
Water circulation noises .....	24
Water connections	
Checking the connections .....	32
Water preheated by solar energy .....	24

## Notes

## Notes



Robert Bosch (Australia) Pty Ltd  
Thermotechnology Division  
1555 Centre Road  
Clayton Victoria 3168

Australia  
Phone: 1300 30 70 37  
Fax: 1300 30 70 38  
[www.bosch-climate.com.au](http://www.bosch-climate.com.au)

New Zealand  
Phone: 0800 54 33 52  
Fax: 0800 54 33 55  
[www.bosch-climate.co.nz](http://www.bosch-climate.co.nz)